



CAMPBELL



Over the decades, thousands of tough applications and just as many demanding customers have forged the Campbell brand. Today, Campbell industrial rigging solutions stand for strength. Campbell industrial fittings are closed-die drop-forged for superior strength and performance, and all alloy lifting chains and associated alloy chain fittings are 100% load-tested to at least 2X the working load limit as “proof” of their reliability. Campbell chain and fittings are designed to maximize performance and expertly manufactured at our Pennsylvania and South Carolina plants by skilled American craftsmen. Trust Campbell performance: **100% American strong.**

SINGLE-SOURCE RIGGING SOLUTIONS

Campbell’s in-house team of chain, fitting and rigging specialists will find the right solution for your job. With more than 40 qualified technical and training professionals

throughout North America, you’re never far from expert advice or the right answer. Campbell’s technical support, expertise and training provide total customer satisfaction with our full line of material-handling products.

WHEN YOU NEED IT NOW, CALL CAMPBELL FIRST

You have deadlines to meet, onsite inspections to pass, customers to satisfy. You have zero tolerance for downtime or delivery promises that aren’t kept. So when you need 3,000 feet of Grade 100 chain or a replacement clamp ASAP or the job won’t meet deadline, we’ll deliver it fast to your jobsite from one of two Campbell distribution centers in the U.S. and Canada, even hot-shotting it your way, if necessary.

Whether you’re positioning 6-metric ton steel plates on a new bridge or trucking heavy equipment and structures cross-country, there’s no rigging job too challenging for Campbell. Specify Campbell chain and rigging solutions — **100% American strong.**



Chain Products 3

Accessories 39

Fittings 63

Blocks 83

Slings 91

Clamps 119

Index 128





CHAINS

Grade 30	7
Mooring	10
Grade 43	10
Sweep.....	12
Deck Lashing	12
Marine Alloy Trawl	13
Grade 70	13
Marine	15
Grade 80	16
Grade 100	17
Aluminum	17
Studio	18
Straight/Twist Link.....	19
Passing Link	23
Handy Link Utility.....	24
Lock Link	24
Brass Plumber's	25
Inco.....	26
Single Jack.....	28
Double Jack.....	29
Sash.....	30
Decorator.....	31
Hobby/Craft.....	32
Oval Link	33
Plastic.....	33
Cable.....	34
Construction	35
Log.....	35
Binder	36
Tow	37
Hydraulic Chain Cutters.....	38



Campbell® Chain

Founded in 1919, Campbell® is one of the largest manufacturers of welded chain in the United States. Users of Campbell chain can select from a wide range of working load capacities including proof coil, high test, transport and alloy; finishes including self-colored, zinc plated, galvanized and bright color polycoated; links that are short, long, twisted, locked, looped, even stamped from flat stock. Several chain types are even available in solid brass and bronze.

Campbell® chains and assemblies, including slings for overhead lifting, and binder chains, have earned for the manufacturer an outstanding reputation for quality.

Important Chain Terms

WORKING LOAD LIMIT

The “working load limit” (rated capacity) is the maximum combined static and dynamic load in pounds or kilograms that should never be applied to the product in service, even when the product is new, and when the load is uniformly applied in direct tension to the product.

PROOF TEST

The “proof test” is a quality control test applied to chain for the purpose of verifying weld and material quality. It is the minimum force in pounds or newtons that the chain has withstood in

direct tension as part of the manufacturing process. Proof testing assures that the chain is more than capable of performing at its rated working load limit. Proof test loads are a manufacturing integrity test and shall not be used as criteria for service or design purposes. All Campbell proof tested chain and components are proof tested in accordance with the applicable ASTM, NACM and AISI/ASME requirements.

Campbell chain products and components are designed and built for rugged lasting service. As with any quality product certain precautions and standards of treatment should be observed.

Finish Abbreviations

(BRT) stands for Bright.

A finish where the surface is cleaned by shot peening or tumbling to produce a clean bright surface

(GALV) stands for Hot-dip Galvanized.

Hot-dip galvanizing is a process where the chain is immersed in molten zinc. This produces both a chemical reaction between the steel and the zinc, as well as an outside layer of zinc on the chain. The end result is an adherent coating of zinc that is much thicker than that produced by zinc electroplating. Corrosion resistance is proportional to zinc thickness, and therefore galvanized products offer superior corrosion resistance to electroplated products.

Note: Due to the temperature of the molten zinc, the strengths of hot-dip galvanized products are often reduced by 15%

(Polycoated)

A finish where the chain is coated with a colored plastic powder which is then fused onto each link.

(S.C.) stands for Self Colored.

A finish without any cleaning operations to remove oil or dirt or surface oxidation from the welding process

(Y.C.) stands for Yellow Chromate.

A name for Campbell’s method of zinc electroplating with a yellow chromate finish. The zinc electroplating is an attractive finish that also serves to prevent the onset of rust on the chain. The chromate finish serves to protect the zinc electroplate

(Z.P.) stands for Zinc Plated.

Campbell’s method of zinc electroplating. The zinc electroplating is an attractive finish that also serves to prevent the onset of rust on the chain.



Campbell® CAMTROL System

Campbell's CAMTROL SYSTEM makes chain products easier to identify and understand. That's because all are based on engineering formulas computed according to ISO (International Organization for Standardization), NACM (National Association of Chain Manufacturers) and ASTM (American Society for Testing and Materials).

Use the CAMTROL SYSTEM to make wise chain purchasing decisions. Use it to compare the various categories of chain, to choose the right chain for the job according to the price per thousand pounds of working load instead of buying on a price per foot.

Consult your Campbell Chain distributor for current prices. Then refer to the chart below and divide the price per foot by the working load limit (in thousands of pounds) shown in the table. By using this comparison system you will discover that you can

buy a smaller, easier to handle chain, and at less cost based on its working load limit.

Variations in Finish or Heat Treatment

The mechanical properties shown on the Camtrol Chart apply only to the various chains in their standard finish and heat treated condition. Finishes such as galvanizing or electroplating may reduce strengths. The manufacturer's revised recommendations should be solicited when such treatments are desirable for specific applications.

Hallmarking (Identification)

All System 4, 7, 8, and 10 chains and all System 3 chains 5/16" (8 mm) and larger are marked with the grade identifier approximately every 12" or less. Please refer to the chain type of interest in this catalog for the specific hallmarks.

Grade	Camtrol System Number	Trade Size		Diameter		Nominal Dimensions				Weight Per 100 Feet		Working Load Limit	
		in.	mm	in.	mm	Inside Length		Inside Width		lb	kg	lb	kg
						in.	mm	in.	mm				
30	3	1/8	4	.156	4.0	.89	22.61	.29	7.33	22	10	400	180
30	3	3/16	5.5	.205	5.5	.95	24.13	.34	8.63	35	16	800	365
30	3	1/4	7	.260	7.0	1.20	30.50	.45	11.40	56	25	1,300	580
30	3	5/16	8	.312	8.0	1.27	32.27	.47	11.93	83	38	1,900	860
30	3	3/8	10	.369	10.0	1.36	34.46	.57	14.47	125	57	2,650	1,200
30	3	1/2	13	.480	13.0	1.70	43.18	.75	19.00	237	108	4,500	2,030
30	3	5/8	16	.656	16.7	2.10	53.34	.87	22.09	390	177	6,900	3,130
30	3	3/4	20	.781	19.8	2.70	68.58	1.02	26.00	535	243	10,600	4,810
30	3	7/8	22	.906	23.0	2.34	59.44	1.37	34.80	770	349	12,800	5,810
43	4	1/4	7	.276	7.0	1.20	30.50	.45	11.40	63	28	2,600	1,180
43	4	5/16	8	.330	8.4	1.27	32.27	.47	11.94	102	46	3,900	1,770
43	4	3/8	10	.394	10.0	1.15	29.21	.58	14.73	160	73	5,400	2,450
43	4	7/16	11.9	.468	11.9	1.29	32.77	.67	17.02	216	98	7,200	3,270
43	4	1/2	13	.531	13.0	1.70	43.18	.75	19.00	260	118	9,200	4,170
43	4	5/8	16	.656	16.7	1.94	49.27	.93	23.62	356	161	13,000	5,910
43	4	3/4	20	.781	23.0	2.21	56.13	1.10	27.94	535	243	20,200	9,180
70	7	1/4	7	.312	7.9	.94	23.88	.46	11.68	91	41	3,150	1,430
70	7	5/16	8.7	.343	8.7	1.01	25.65	.48	11.68	111	50	4,700	2,130
70	7	3/8	10	.406	10	1.36	34.46	.57	14.47	150	68	6,600	2,990
70	7	7/16	11.9	.468	11.9	1.29	32.77	.67	17.02	212	96	8,750	3,970
70	7	1/2	13	.531	13.0	1.70	43.18	.75	19.00	260	118	11,300	5,130
70	7	5/8	16	.630	16.0	1.93	49.02	.87	22.10	375	170	15,800	7,170
80	8	5/16	8	.315	8.0	.94	23.88	.46	11.68	92	42	4,500	2,000
80	8	1	26	1.000	25.4	2.80	71.12	1.40	35.56	965	438	47,700	21,600
80	8	1 1/4	32	1.250	31.8	3.50	88.90	1.75	44.45	1525	692	72,300	32,800
100	10	9/32	7	.285	7.2	.86	21.80	.41	11.40	74	34	4,300	1,950
100	10	3/8	10	.402	10.2	1.22	31.00	.55	14.00	148	67	8,800	3,990
100	10	1/2	13	.522	13.2	1.54	39.90	.45	19.10	250	113	15,000	6,800
100	10	5/8	16	.643	16.3	1.93	49.00	.87	22.10	379	172	22,600	10,250
100	10	3/4	20	.802	20.4	2.42	61.50	1.09	27.70	598	271	35,300	16,000
100	10	7/8	22	.882	22.4	2.70	68.52	1.28	32.48	775	351	42,700	19,400

Warnings, Cautions, Inspection and Proper Use of Chain

Proper care will extend the useful life of the product.

INSTRUCTIONS REGARDING COMPONENTS AND FITTINGS

Components, such as hooks or shackles, should have at least the same working load limit (rated capacity) as the chain with which they are used. If not, the assembly shall be rated to the capacity of the weakest component. Campbell offers a full line of components engineered specifically to be compatible with our chain products.

WARNINGS AND CAUTIONS

- The use of chain is subject to certain hazards that cannot be met by mechanical or manufacturing means, but only by the exercise of intelligence, care, and common sense
- Do not exceed the working load limit of the chain or any component
- Chemically active environments may adversely affect chain and components. Do not use in highly acidic or caustic environments. Campbell should be contacted if the chain will be exposed to chemically active environments during use
- High and low temperatures will affect chain and components. Campbell should be contacted if temperatures below -20°F (-29°C) or above 400°F (200°C) will be experienced
- Chains used in certain applications are subject to governmental regulations. Please follow all Federal, State and/or Local Department of Transportation, OSHA, or other applicable standards and regulations when using Campbell products
- Never field weld or repair chain
- See other specific information under “Inspection and Proper Use”

INSPECTION

Regular inspections should be conducted on chain to detect damage or deterioration from use. The chain should be inspected for any of the below conditions. If present, the chain should immediately be removed from service.

- Cracks in the chain or any component
- Excessive nicks or gouges
- Excessive wear. Chain should be removed from service if the thickness at any point on the link is below the value shown in the **Chain Minimum Allowable Thickness** chart. All other components should be removed from service if any dimension is worn by more than 10% from the original dimension
- Stretched, bent, twisted, or distorted chain links or components
- Excessive corrosion
- Evidence of heat damage
- Evidence of field welding or weld splatter
- Any other condition which questions the integrity of the chain

PROPER USE

To protect the users and to prevent damage to the chain, the following safe practices should be followed:

- Select a chain suitable for the application and environment
- The hooks or other components should be of a size to fit the intended connections
- Avoid shock loading
- Pad all sharp edges or corners in contact with the chain
- Rig so that the load is properly seated in the hooks or other components. Avoid tip loading of hooks and side loading of chain and components
- Avoid twisting or kinking the chain
- Never knot chain

Purchasers please note that all “Warnings and Cautions” apply to chain as well as all components and fittings. Purchasers are responsible for conveying the “Warnings and Cautions,” including the “Inspection” and “Proper Use” section information to the end user.

Campbell denies any liability for damage that results from use in excess of the working load limit or any abuse or misuse of the product.

Any questions concerning the use of Campbell products may be directed to your Hillman Group Sales representative or a Hillman Group Customer Service representative.

OTHER PRODUCTS

Campbell produces a number of products for specialty applications. Please contact your Hillman Group Sales representative, or Customer Service representative, if you have special requirements.

Not all products produced by Campbell appear in this catalog. Campbell can produce engineered chain to meet customer design specifications, and also produces a variety of chain assemblies. Minimum order quantities may apply to special order products.

NOTICE: The product specifications and dimensions are as accurate as possible at the time of printing. However, because we are continually improving the quality and design of our products, they can change without notice. The dimensions and weights are approximate nominal values, and some variation will occur. If specific dimensional requirements are necessary for the application, please contact your Hillman Group Sales representative, or Customer Service representative.



Chain Minimum Allowable Thickness Chart

Trade Size		Chain Type or Grade	Nominal Material Diameter		Min. Allowable Thickness on Link	
in.	mm		in.	mm	in.	mm
4	3.0	Machine, Coil	0.120	3.0	0.104	2.64
3	3.4	Machine, Coil	0.135	3.4	0.117	2.97
2	3.8	Machine, Coil	0.148	3.8	0.128	3.25
1	4.1	Machine, Coil	0.162	4.1	0.140	3.56
1/0	4.5	Machine, Coil	0.177	4.5	0.153	3.89
2/0	4.9	Machine, Coil, Passing Link	0.192	4.9	0.166	4.22
3/0	5.3	Machine, Coil	0.207	5.3	0.179	4.55
4/0	5.5	Machine, Coil, Passing Link	0.218	5.5	0.189	4.80
5/0	6.4	Machine, Coil	0.250	6.4	0.217	5.50
1/8	4.0	Grade 30	0.156	4.0	0.135	3.43
3/16	5.5	Grade 30, 80, 100	0.217	5.5	0.189	4.80
1/4-9/32	7.0	Grade 30, 43, 70, 80, 100 (Grade 43 = 0.281)	0.276	7.0	0.239	6.07
5/16	8.4	Grade 30	0.331	8.4	0.286	7.28
5/16	8.7	Grade 43, 70	0.343	8.7	0.297	7.54
5/16	8.0	Grade 80, 100	0.312	8.0	0.273	6.93
3/8	10.0	Grade 30, 80, 100	0.394	10.0	0.342	8.69
3/8	10.3	Grade 43, 70	0.406	10.3	0.351	8.93
7/16	11.9	Grade 30, 43, 70	0.468	11.9	0.405	10.30
1/2	13.0	Grade 30, 80, 100	0.512	13.0	0.443	11.26
1/2	13.5	Grade 43, 70	0.531	13.5	0.460	11.68
5/8	16.0	Grade 30, 43, 70	0.630	16.0	0.546	13.87
3/4	20.0	Grade 80, 100	0.787	20.0	0.687	17.45
7/8	20.0	Grade 30, 43, 80, 100	0.866	22.0	0.750	19.05
1	26.0	Grade 30, 80	1.020	26.0	0.887	22.53
1-1/4	32.0	Grade 80	1.260	32.0	1.091	27.71
1-1/2	38.0	Grade 63	1.500	38.0	1.300	32.99

 **Warning:** Remove chain from service if the thickness is less than the minimum shown, at any location on the link

ADVERTENCIA

Para prevenir la posibilidad de una lesión personal seria:

- **NO EXCEDA** los límites de carga de las cadenas o componentes.
- **NO LA UTILICE** para cargar hacia arriba o para izar.
- **NO LA UTILICE** si la cadena o los componentes están visualmente distorsionados o gastados.

WARNING

To prevent the possibility of serious bodily injury:

- **DO NOT EXCEED** the working load limits for chain or components.
- **DO NOT USE** for overhead lifting or hoisting.
- **DO NOT USE** if the chain or components are visibly distorted or worn.



Grade 30, Proof Coil Chain - Drums

- Excellent Low Carbon Steel Chain for General Purpose Applications
- Frequently Used for Fabricating Tow Chains, Binding and Logging Chains, Marine and Other General Applications
- Standard Finish: Self Colored, Zinc Plated or Galvanized
- Hallmarking: "C3" and "USA" on 5/16" and Larger
- Proof Tested
- Design Factor: 4 to 1
- Packaged in Drums, Order Unit is "Feet"
- Made in the USA
- Do Not Use for Overhead Lifting
- DO NOT EXCEED THE WORKING LOAD LIMIT



Trade Size	Finish			UPC No. 020418+	UPC No. 020418+	Material Diameter	Inside Length	Inside Width	Working Load Limit	Feet Per Pkg	Links Per Ft	Weight Per Pkg	
	Self-Colored	Galvanized	Zinc Plated										
1/8 in	T0120202	056932	T0120232	056949	—	—	0.16 in	0.88 in	0.27 in	400 lb	1000 ft	13.5	190 lb
3/16 in	T0120302	056970	T0120332	057045	T0120322	057007	0.21 in	0.95 in	0.34 in	800 lb	1000 ft	12.6	350 lb
1/4 in	T0120402	057076	T0120432	057144	T0120422	057106	0.26 in	1.20 in	0.45 in	1300 lb	800 ft	10	460 lb
5/16 in	T0120502	057205	T0120532	057281	T0120522	057243	0.31 in	1.27 in	0.47 in	1900 lb	550 ft	9.4	482 lb
3/8 in	T0120602	057335	T0120632	057410	T0120622	057373	0.37 in	1.36 in	0.57 in	2650 lb	400 ft	8.8	500 lb
7/16 in	—	—	T0120732	057489	—	—	0.47 in	1.37 in	0.75 in	3700 lb	300 ft	8.8	660 lb
1/2 in	T0120802	057502	T0120832	057557	T0120822	057526	0.48 in	1.70 in	0.75 in	4500 lb	200 ft	7.1	420 lb
5/8 in	T0121002	057595	T0121032	057618	—	—	0.66 in	2.10 in	0.87 in	6900 lb	150 ft	5.7	610 lb
3/4 in	T0121202	057632	T0121232	057656	—	—	0.78 in	2.70 in	1.02 in	10600 lb	100 ft	4.4	560 lb

Grade 30, Proof Coil Chain - Half Drums

- Excellent Low Carbon Steel Chain for General Purpose Applications
- Frequently Used for Fabricating Tow Chains, Binding and Logging Chains, Marine and Other General Applications
- Standard Finish: Self Colored or Galvanized
- Hallmarking: "C3" and "USA" on 5/16" and Larger
- Proof Tested
- Design Factor: 4 to 1
- Packaged in Half Drums, Order Unit is "Feet"
- Made in the USA
- Do Not Use for Overhead Lifting
- DO NOT EXCEED THE WORKING LOAD LIMIT



Trade Size	Finish		UPC No. 020418+	UPC No. 020418+	Material Diameter	Inside Length	Inside Width	Working Load Limit	Feet Per Pkg	Links Per Ft	Weight Per Pkg
	Self-Colored	Galvanized									
3/16 in	T0120300	056956	T0120330	057021	0.21 in	0.95 in	0.34 in	800 lb	500 ft	12.6	175 lb
1/4 in	T0120400	057052	T0120430	057120	0.26 in	1.20 in	0.45 in	1300 lb	400 ft	10	230 lb
5/16 in	T0120500	057182	T0120530	057267	0.31 in	1.27 in	0.47 in	1900 lb	275 ft	9.4	241 lb
3/8 in	T0120600	057311	T0120630	057397	0.37 in	1.36 in	0.57 in	2650 lb	200 ft	8.8	250 lb



Grade 30, Proof Coil Chain - Round Pails



- Excellent Low Carbon Steel Chain for General Purpose Applications
- Frequently Used for Fabricating Tow Chains, Binding and Logging Chains, Marine and Other General Applications
- Standard Finish: Zinc Plated or Galvanized
- Hallmarking: "C3" and "USA" on 5/16" and Larger
- Proof Tested
- Design Factor: 4 to 1
- Packaged in Pails, Order Unit is "Each"
- Made in the USA
- Do Not Use for Overhead Lifting
- DO NOT EXCEED THE WORKING LOAD LIMIT



Trade Size	Finish		UPC No. 020418+	UPC No. 020418+	Material Diameter	Inside Length	Inside Width	Working Load Limit	Feet Per Pkg	Links Per Ft	Weight Per Pkg
	Zinc Plated Cat. No.	Galvanized Cat. No.									
3/16 in	T0140323	057991	T0140333	058004	0.21 in	0.95 in	0.34 in	800 lb	250 ft	12.6	88 lb
1/4 in	T0140423	058028	T0140433	058035	0.26 in	1.20 in	0.45 in	1300 lb	141 ft	10	79 lb
5/16 in	T0140523	058059	T0140533	058066	0.31 in	1.27 in	0.47 in	1900 lb	92 ft	9.4	76 lb
3/8 in	T0140623	058080	T0140633	058097	0.37 in	1.36 in	0.57 in	2650 lb	63 ft	8.8	79 lb
1/2 in	T0140823	058103	—	—	0.48 in	1.70 in	0.75 in	4500 lb	40 ft	7.1	95 lb

Grade 30, Proof Coil Chain - Square Pails



- Excellent Low Carbon Steel Chain for General Purpose Applications
- Frequently Used for Fabricating Tow Chains, Binding and Logging Chains, Marine and Other General Applications
- Standard Finish: Zinc Plated or Galvanized
- Hallmarking: "C3" and "USA" on 5/16" and Larger
- Proof Tested
- Design Factor: 4 to 1
- Packaged in Pails, Order Unit is "Each"
- Made in the USA
- Do Not Use for Overhead Lifting
- DO NOT EXCEED THE WORKING LOAD LIMIT



Trade Size	Finish		UPC No. 020418+	UPC No. 020418+	Material Diameter	Inside Length	Inside Width	Working Load Limit	Feet Per Pkg	Links Per Ft	Weight Per Pkg
	Zinc Plated Cat. No.	Galvanized Cat. No.									
1/8 in	T0143226	190360	—	—	0.16 in	0.88 in	0.27 in	400 lb	200 ft	13.5	38 lb
3/16 in	T0143326	183058	T0143336	183065	0.21 in	0.95 in	0.34 in	800 lb	150 ft	12.6	53 lb
1/4 in	T0143426	183072	T0143436	183089	0.26 in	1.20 in	0.45 in	1300 lb	100 ft	10	56 lb
5/16 in	T0143526	183096	T0143536	183102	0.31 in	1.27 in	0.47 in	1900 lb	75 ft	9.4	62 lb
3/8 in	T0143626	183119	T0143636	183126	0.37 in	1.36 in	0.57 in	2650 lb	45 ft	8.8	56 lb



CHAIN

Grade 30, Polycoated, Proof Coil Chain - Square Pails

- Excellent Low Carbon Steel Chain for General Purpose Applications
- Frequently Used for Swing Sets, Borders, Crowd Control and Other General Applications
- Standard Finish: Polycoated Yellow
- Proof Tested
- Design Factor: 4 to 1
- Made in the USA
- Order Unit Is "Each"
- Do Not Use for Overhead Lifting
- DO NOT EXCEED THE WORKING LOAD LIMIT



Trade Size	Cat. No.	UPC No.	Material Diameter	Inside Length	Inside Width	Finish	Working Load Limit	Feet Per Pkg	Links Per Ft	Weight Per Pkg	Shelf Pack Qty.
1/4 in	PD0143426	020418212185	0.26 in	1.20 in	0.45 in	Yellow Polycoat	1300 lb	75 ft	10	45 lb	1

Grade 30, Proof Coil Chain - Reels

- Excellent Low Carbon Steel Chain for General Purpose Applications
- Frequently Used for Swing Sets, Borders, Crowd Control and Other General Applications
- Standard Finish: Zinc Plated or Polycoated Yellow
- Hallmarking: "C3" and "USA" on 5/16" and Larger
- Proof Tested
- Design Factor: 4 to 1
- Packaged on Reels, Order Unit is "Each"
- Made in the USA
- Do Not Use for Overhead Lifting
- DO NOT EXCEED THE WORKING LOAD LIMIT



Trade Size	Finish		UPC No. 020418+	UPC No. 020418+	Material Diameter	Inside Length	Inside Width	Working Load Limit	Feet Per Pkg	Links Per Ft	Reel Width	Weight Per Pkg
	Zinc Plated Cat. No.	Polycoat Cat. No.										
3/16 in	T0725027	064982	PD0725027	184642	0.21 in	0.95 in	0.34 in	800 lb	100 ft	12.6	10.75 in	38 lb
1/4 in	T0722127	183270	—	—	0.26 in	1.20 in	0.45 in	1300 lb	65 ft	10	10.75 in	41 lb
1/4 in	—	—	PD0722127	183393	0.26 in	1.20 in	0.45 in	1300 lb	60 ft	10	10.75 in	36 lb
5/16 in	T0722227	183287	—	—	0.31 in	1.27 in	0.47 in	1900 lb	60 ft	9.4	10.75 in	50 lb
3/8 in	T0722327	183294	—	—	0.37 in	1.36 in	0.57 in	2650 lb	35 ft	8.8	10.75 in	44 lb



Mooring Chain - Drums

- Excellent Low Carbon Steel Chain with A Long Link Design for Mooring Applications
- The Longer Link Allows the Use of A Shackle Anywhere in the Length of Chain, Not Just at End Links
- Greater Working Load Limit Than Proof Coil
- Hot Dipped Galvanized Finish
- Hallmarking: "MC" and "USA"
- Proof Tested
- Design Factor: 4 to 1
- Made in the USA
- Do Not Use for Overhead Lifting
- DO NOT EXCEED THE WORKING LOAD LIMIT



Trade Size	Cat. No.	UPC No.	Material Diameter	Inside Length	Inside Width	Working Load Limit	Feet Per Pkg	Links Per Ft	Weight Per Pkg
3/8 in	T0129332	020418152108	0.41 in	1.23 in	0.62 in	3700 lb	400 ft	9.7	536 lb
1/2 in	T0129432	020418152092	0.51 in	2.05 in	0.83 in	6000 lb	200 ft	8	460 lb
5/8 in	T0129532	020418152078	0.63 in	2.52 in	0.94 in	9000 lb	150 ft	4.7	510 lb
3/4 in	T0129632	020418152085	0.79 in	3.00 in	1.16 in	13500 lb	100 ft	4	554 lb

Grade 43, High Test Chain - Drums

- Designed for Use in Load Binding, Towing, Logging and Other Applications Requiring High Strength
- Standard Material: Carbon Steel
- Standard Finish: Self Colored or Bright, Zinc Plated or Galvanized
- Hallmarking: "C4" All Sizes and "USA" on 1/4" and 5/16"
- Proof Tested
- Design Factor: 3 to 1
- Packaged in Drums, Order Unit is "Feet"
- Made in the USA
- Do Not Use for Overhead Lifting
- DO NOT EXCEED THE WORKING LOAD LIMIT



Trade Size	Cat. No.	UPC No.	Material Diameter	Inside Length	Inside Width	Finish	Working Load Limit	Feet Per Pkg	Links Per Ft	Weight Per Pkg
1/4 in	T0180412	020418058769	0.28 in	1.20 in	0.45 in	Self-Colored	2600 lb	800 ft	10	504 lb
1/4 in	T0180422	020418058790	0.28 in	1.20 in	0.45 in	Zinc Plated	2600 lb	800 ft	10	504 lb
1/4 in	T0180432	020418058820	0.28 in	1.20 in	0.45 in	Galvanized	2600 lb	800 ft	10	504 lb
5/16 in	T0180512	020418058851	0.33 in	1.27 in	0.47 in	Self-Colored	3900 lb	550 ft	9.4	523 lb
5/16 in	T0180522	020418058882	0.33 in	1.27 in	0.47 in	Zinc Plated	3900 lb	550 ft	9.4	523 lb
5/16 in	T0180532	020418058912	0.33 in	1.27 in	0.47 in	Galvanized	3900 lb	550 ft	9.4	523 lb
3/8 in	T0180612	020418058943	0.38 in	1.36 in	0.58 in	Self-Colored	5400 lb	400 ft	8.8	520 lb
3/8 in	T0180632	020418059018	0.38 in	1.36 in	0.58 in	Galvanized	5400 lb	400 ft	8.8	520 lb
1/2 in	T0180812	020418059094	0.53 in	1.70 in	0.75 in	Self-Colored	9200 lb	200 ft	7.1	520 lb
1/2 in	T0180832	020418059155	0.53 in	1.70 in	0.75 in	Galvanized	9200 lb	200 ft	7.1	520 lb
5/8 in	T0181012	020418059186	0.66 in	1.94 in	0.93 in	Bright	13000 lb	150 ft	6.2	534 lb
5/8 in	T0181032	020418059216	0.66 in	1.94 in	0.93 in	Galvanized	13000 lb	150 ft	6.2	534 lb
3/4 in	T0181212	020418059254	0.78 in	2.21 in	1.10 in	Bright	20200 lb	100 ft	5.4	581 lb



Grade 43, High Test Chain - Round Pails

- Designed for Use in Load Binding, Towing, Logging and Other Applications Requiring High Strength
- Standard Material: Carbon Steel
- Standard Finish: Bright and Zinc Plated
- Hallmarking: "C4" All Sizes and "USA" on 1/4" and 5/16"
- Proof Tested
- Design Factor: 3 to 1
- Packaged in Pails, Order Unit is "Each"
- Made in the USA
- Do Not Use for Overhead Lifting
- DO NOT EXCEED THE WORKING LOAD LIMIT



Trade Size	Finish		UPC No. 020418+	UPC No. 020418+	Material Diameter	Inside Length	Inside Width	Working Load Limit	Feet Per Pkg	Links Per Foot	Weight Per Pkg
	Bright Cat. No.	Zinc Plated Cat. No.									
1/4 in	T0181413	059278	T0181423	059285	0.28 in	1.20 in	0.45 in	2600 lb	150 ft	10	98 lb
5/16 in	T0181513	059292	T0181523	059308	0.33 in	1.27 in	0.47 in	3900 lb	100 ft	9.4	95 lb
3/8 in	T0181613	059315	T0181623	059322	0.38 in	1.36 in	0.58 in	5400 lb	75 ft	8.8	98 lb

Grade 43, High Test Chain - Square Pails

- Designed for Use in Load Binding, Towing, Logging and Other Applications Requiring High Strength
- Standard Material: Carbon Steel
- Standard Finish: Bright and Galvanized
- Hallmarking: "C4" All Sizes and "USA" on 1/4" and 5/16"
- Proof Tested
- Design Factor: 3 to 1
- Packaged in Pails, Order Unit is "Each"
- Made in the USA
- Do Not Use for Overhead Lifting
- DO NOT EXCEED THE WORKING LOAD LIMIT



Trade Size	Finish		UPC No. 020418+	UPC No. 020418+	Material Diameter	Inside Length	Inside Width	Working Load Limit	Feet Per Pkg	Links Per Ft	Weight Per Pkg
	Bright Cat. No.	Galvanized Cat. No.									
1/4 in	T0184416	183133	—	—	0.28 in	1.20 in	0.45 in	2600 lb	100 ft	10	66 lb
5/16 in	T0184516	183140	T0184536	185878	0.33 in	1.27 in	0.47 in	3900 lb	60 ft	9.4	57 lb
3/8 in	T0184616	183157	T0184636	185885	0.38 in	1.36 in	0.58 in	5400 lb	40 ft	8.8	52 lb



Grade 43, Polycoated, High Test Chain - Square Pails

- Designed for Use in Load Binding, Towing, Logging and Other Applications Requiring High Strength
- Standard Material: Carbon Steel
- Standard Finish: Polycoated Hi-Visibility Orange
- Hallmarking: "C4" All Sizes and "USA" on 1/4" and 5/16"
- Proof Tested
- Design Factor: 3 to 1
- Packaged in Pails, Order Unit is "Each"
- Made in the USA
- Do Not Use for Overhead Lifting
- DO NOT EXCEED THE WORKING LOAD LIMIT



Trade Size	Cat. No.	UPC No.	Material Diameter	Inside Length	Inside Width	Finish	Working Load Limit	Feet Per Pkg	Links Per Ft	Weight Per Pkg
5/16 in	HV0184526	020418187698	0.33 in	1.27 in	0.47 in	Polycoat	3900 lb	60 ft	9.4	50 lb

Sweep Chain - Drums

- Produced Specifically for Scallop and Oyster Dredging
- Thru Hardened for Wear Resistance
- Hallmarking: "CC" and "USA"
- Proof Tested
- Design Factor: 4 to 1
- Packaged in Drums, Order Unit is "Feet"
- Made in the USA
- Do Not Use for Overhead Lifting
- DO NOT EXCEED THE WORKING LOAD LIMIT



Trade Size	Cat. No.	UPC No.	Material Diameter	Inside Length	Inside Width	Working Load Limit	Feet Per Pkg	Links Per Ft	Weight Per Pkg
5/8 in	T0181092	020418179921	0.66 in	1.94 in	0.93 in	15800 lb	150 ft	6.2	614 lb

Deck Lashing Chain

- Used to Secure Cargo on Ship Decks
- Features a Long Link Design
- Heat Treated Carbon Steel
- Hot Galvanized Finish
- Proof Tested
- Hallmarking: "CCL" and "USA"
- Design Factor: 4 to 1
- Compliant with "Canadian Code of Safe Practice for Ships Carrying Timber Deck Cargoes (TP 2534E-1992)"
- Packaged in Pallet Box, Order Unit is "Feet"
- DO NOT EXCEED THE WORKING LOAD LIMIT



Trade Size	Cat. No.	UPC No.	Material Diameter	Inside Length	Inside Width	Working Load Limit	Feet Per Pkg	Links Per Ft	Weight Per Pkg	Shelf Pack
1/2 in	T0187232	020418181511	0.53 in	3.15 in	0.99 in	9000 lb	1000 ft	3.8	2200 lb	1



Marine Alloy Trawl Chain - Drums

- Made of High Strength, Heat Treated Alloy Steel
- Designed for Use with the Larger Nets in the Trawling Industry
- Special Heat Treatment for the Trawling Industry
- Grade 80 Strengths
- Hallmarking: "NETS8" and Date Code
- Proof Tested
- Design Factor: 4 to 1
- Packaged in Drums, Order Unit is "Feet"
- Made in the USA
- DO NOT EXCEED THE WORKING LOAD LIMIT



Trade Size	Cat. No.	UPC No.	Chain Type	Inside Length	Inside Width	Working Load Limit	Feet Per Pkg	Weight Per Pkg
1/2 in	T0407512	020418190452	Long Link	3.15 in	0.97 in	12000 lb	300 ft	570 lb
5/8 in	T0407612	020418363788	Long Link	3.71 in	1.00 in	18100 lb	100 ft	473 lb

Grade 70, Transport Chain - Drums

- Designed for Use in Load Binding, Towing, Logging and Other Applications Requiring High Strength
- Can Be Used in Accordance with Department of Transportation Regulations
- Standard Material: Heat Treated Carbon Steel
- Standard Finish: Zinc Electroplate with Yellow Chromate Conversion Coating
- Hallmarking: "C7" and "USA"
- Proof Tested
- Design Factor: 4 to 1
- Packaged in Drums, Order Unit is "Feet"
- Do Not Use for Overhead Lifting
- DO NOT EXCEED THE WORKING LOAD LIMIT



Trade Size	Cat. No.	UPC No.	Material Diameter	Inside Length	Inside Width	Finish	Working Load Limit	Feet Per Pkg	Links Per Ft	Weight Per Pkg
1/4 in	T0510412	020418063763	0.31 in	0.94 in	0.46 in	Yellow Chromate	3150 lb	800 ft	12.8	752 lb
5/16 in	T0510512	020418063800	0.34 in	1.15 in	0.48 in	Yellow Chromate	4700 lb	550 ft	10.4	561 lb
3/8 in	T0510612	020418063848	0.40 in	1.36 in	0.57 in	Yellow Chromate	6600 lb	400 ft	8.8	600 lb
7/16 in	T0510712	020418063886	0.47 in	1.29 in	0.67 in	Yellow Chromate	8750 lb	300 ft	9.3	636 lb
1/2 in	T0510812	020418063916	0.53 in	1.70 in	0.75 in	Yellow Chromate	11300 lb	200 ft	7.1	520 lb



Grade 70, Transport Chain - Half Drums

- Designed for Use in Load Binding, Towing, Logging and Other Applications Requiring High Strength
- Can Be Used in Accordance with Department of Transportation Regulations
- Standard Material: Heat Treated Carbon Steel
- Standard Finish: Zinc Electroplate with Yellow Chromate Conversion Coating
- Hallmarking: "C7" and "USA"
- Proof Tested
- Design Factor: 4 to 1
- Packaged in Half Drums, Order Unit is "Feet"
- Do Not Use for Overhead Lifting
- DO NOT EXCEED THE WORKING LOAD LIMIT



Trade Size	Cat. No.	UPC No.	Material Diameter	Inside Length	Inside Width	Finish	Working Load Limit	Feet Per Pkg	Links Per Ft	Weight Per Pkg
1/4 in	T0510410	020418063749	0.31 in	0.94 in	0.46 in	Yellow Chromate	3150 lb	400 ft	12.8	376 lb
5/16 in	T0510510	020418063787	0.34 in	1.15 in	0.48 in	Yellow Chromate	4700 lb	275 ft	10.4	280 lb
3/8 in	T0510610	020418063824	0.40 in	1.36 in	0.57 in	Yellow Chromate	6600 lb	200 ft	8.8	300 lb
1/2 in	T0510810	020418063893	0.53 in	1.70 in	0.75 in	Yellow Chromate	11300 lb	100 ft	7.1	260 lb

Grade 70, Transport Chain - Round Pails

- Designed for Use in Load Binding, Towing, Logging and Other Applications Requiring High Strength
- Can Be Used in Accordance with Department of Transportation Regulations
- Standard Material: Heat Treated Carbon Steel
- Standard Finish: Zinc Electroplate with Yellow Chromate Conversion Coating
- Hallmarking: "C7" and "USA"
- Proof Tested
- Design Factor: 4 to 1
- Packaged in Pails, Order Unit is "Each"
- Do Not Use for Overhead Lifting
- DO NOT EXCEED THE WORKING LOAD LIMIT



Trade Size	Cat. No.	UPC No.	Material Diameter	Inside Length	Inside Width	Finish	Working Load Limit	Feet Per Pkg	Links Per Ft	Weight Per Pkg
1/4 in	T0510413	020418063770	0.31 in	0.94 in	0.46 in	Yellow Chromate	3150 lb	150 ft	12.8	139 lb
5/16 in	T0510513	020418063817	0.34 in	1.27 in	0.47 in	Yellow Chromate	4700 lb	100 ft	10.4	102 lb
3/8 in	T0510613	020418063855	0.40 in	1.36 in	0.57 in	Yellow Chromate	6600 lb	75 ft	8.8	113 lb



Grade 70, Transport Chain - Square Pails

- Designed for Use in Load Binding, Towing, Logging and Other Applications Requiring High Strength
- Can Be Used in Accordance with Department of Transportation Regulations
- Standard Material: Heat Treated Carbon Steel
- Standard Finish: Zinc Electroplate with Yellow Chromate Conversion Coating
- Hallmarking: "C7" and "USA"
- Proof Tested
- Design Factor: 4 to 1
- Packaged in Pails, Order Unit is "Each"
- Do Not Use for Overhead Lifting
- DO NOT EXCEED THE WORKING LOAD LIMIT



Trade Size	Cat. No.	UPC No.	Material Diameter	Inside Length	Inside Width	Finish	Working Load Limit	Feet Per Pkg	Links Per Ft	Weight Per Pkg
1/4 in	T0510426	020418183867	0.31 in	0.94 in	0.46 in	Yellow Chromate	3150 lb	65 ft	12.8	64 lb
5/16 in	T0510526	020418183874	0.34 in	1.27 in	0.47 in	Yellow Chromate	4700 lb	50 ft	10.4	51 lb
3/8 in	T0510626	020418186639	0.40 in	1.36 in	0.57 in	Yellow Chromate	6600 lb	45 ft	8.8	68 lb

Tuna Net Chain - Drums

- Made of High Strength, Heat Treated Steel
- Designed for Sinkers Lines and Bridles in Purse Seining
- Hot Dip Galvanized Finish
- Hallmarking: "ST" and "USA"
- Proof Tested
- Packaged in Drums, Order Unit is "Feet"
- Made in the USA
- Do Not Use for Overhead Lifting
- DO NOT EXCEED THE WORKING LOAD LIMIT



Trade Size	Cat. No.	UPC No.	Material Diameter	Inside Length	Inside Width	Working Load Limit	Feet Per Pkg	Links Per Ft	Weight Per Pkg
3/8 in	T0514632	020418175480	0.41 in	1.36 in	0.57 in	5600 lb	400 ft	9.75	620 lb
1/2 in	T0514832	020418064272	0.50 in	1.70 in	0.75 in	9600 lb	200 ft	7.75	476 lb
5/8 in	T0514932	020418177507	0.63 in	1.93 in	0.87 in	13500 lb	150 ft	6.25	563 lb



Dock Fender Chain - Drums

- High Tensile Chain Holds Thick Rubber Fenders to Dock Sides
- Hot Dipped Galvanized Finish
- Proof Tested
- Hallmarking: "C-DF"
- Packaged in Drums, Order Unit is "Feet"
- Made in the USA
- Do Not Use for Overhead Lifting
- DO NOT EXCEED THE WORKING LOAD LIMIT



Trade Size	Cat. No.	UPC No.	Material Diameter	Inside Length	Inside Width	Working Load Limit	Feet Per Pkg	Weight Per Pkg
5/8 in	T0516531*	020418181887	0.66 in	3.75 in	0.90 in	12500 lb	150 ft	480 lb

* Item is Made to Order

Beacon Fishing Chain

- Standard Material: Heat Treated Carbon Steel
- Standard Finish: Bright (Brt)
- Proof Tested
- Hallmarking: "CB" and "USA"
- Uses: Designed to Accommodate All Types of Chain Needs in the Trawling and Marine Industry
- Packaged in Drums, Order Unit is "Feet"
- Made in the USA
- Do Not Use for Overhead Lifting
- DO NOT EXCEED THE WORKING LOAD LIMIT



Trade Size	Cat. No.	UPC No.	Material Diameter	Inside Length	Inside Width	Working Load Limit	Feet Per Pkg	Links Per Ft	Weight Per Pkg
3/8 in	T0520612	020418064302	0.39 in	1.58 in	0.59 in	6600 lb	200 ft	7.6	268 lb
1/2 in	T0520812	020418064319	0.51 in	2.05 in	0.83 in	11300 lb	200 ft	5.9	460 lb
5/8 in	T0521012	020418064326	0.63 in	2.52 in	0.94 in	15800 lb	200 ft	4.8	680 lb

Grade 80, Cam-Alloy Chain

- Specifically Recommended for Overhead Lifting Applications
- Standard Material: Alloy Steel, Heat Treated
- Standard Finish: Bright
- Hallmarking: "C8", "USA" and Traceability Code
- Proof Tested
- Design Factor: 4 to 1
- Packaged in Drums, Order Unit is "Feet"
- Made in the USA
- DO NOT EXCEED THE WORKING LOAD LIMIT



Trade Size	Cat. No.	UPC No.	Material Diameter	Inside Length	Inside Width	Working Load Limit	Feet Per Pkg	Links Per Ft	Weight Per Pkg
5/16 in	T0400512	020418063367	0.32 in	0.94 in	0.46 in	4500 lb	500 ft	12.8	460 lb
1 in	T0401612	020418063510	1.00 in	3.18 in	1.40 in	47700 lb	100 ft	3.8	940 lb
1-1/4 in	T0402012	020418063534	1.25 in	3.80 in	1.75 in	72300 lb	60 ft	3.5	915 lb



Grade 100, Cam-Alloy Chain

- Specifically Recommended for Overhead Lifting Applications
- 25% Stronger Than Grade 80 Which Enables You to Perform Same Lifts with Lighter Weight Chain
- Standard Material: Alloy Steel, Heat Treated
- Standard Finish: Bright
- Hallmarking: "C10", "USA" and Traceability Code
- Proof Tested
- Design Factor: 4 to 1
- Packaged in Drums, Order Unit is "Feet"
- Made in the USA
- DO NOT EXCEED THE WORKING LOAD LIMIT



Trade Size	Cat. No.	UPC No.	Material Diameter	Inside Length	Inside Width	Working Load Limit	Feet Per Pkg	Links Per Ft	Weight Per Pkg
9/32 in	T0405212	020418182204	0.29 in	0.87 in	0.41 in	4300 lb	500 ft	13.8	370 lb
5/16 in	T0405312	020418245510	0.33 in	1.01 in	0.50 in	5700 lb	500 ft	12	520 lb
3/8 in	T0405412	020418182211	0.40 in	1.22 in	0.57 in	8800 lb	500 ft	10	740 lb
1/2 in	T0405512	020418182228	0.52 in	1.58 in	0.75 in	15000 lb	300 ft	7.8	750 lb
5/8 in	T0405612	020418182235	0.64 in	1.93 in	0.87 in	22600 lb	200 ft	6.5	758 lb
3/4 in	T0405712	020418182242	0.80 in	2.42 in	1.09 in	35300 lb	100 ft	5.5	598 lb
7/8 in	T0405812	020418152924	0.88 in	2.70 in	1.28 in	42700 lb	100 ft	4.4	775 lb

Aluminum Chain



- Standard Material: 5056 Aluminum-Magnesium Alloy
- Standard Finish: Bright (Brt)
- Proof Tested
- Design Factor: 4 to 1
- Uses: Chemical Processing, Petroleum, Refining, Food Processing, Landscaping, Crowd Control, Wherever A Non-Magnetic, Non-Sparking Chain is Needed
- Packaged in Cartons, Order Unit is Feet
- Made in the USA
- Do Not Use for Overhead Lifting or Dynamic Load Conditions
- DO NOT EXCEED THE WORKING LOAD LIMIT



Trade Size	Cat. No.	UPC No.	Material Diameter	Inside Length	Inside Width	Working Load Limit	Feet Per Pkg	Links Per Ft	Weight Per 100 Ft
17/64 in	T0635211	020418176098	0.26 in	1.06 in	0.37 in	550 lb	100 ft	11.3	19



Studio Chain - Carton

- Uses: Hanging Theatrical Lights and Fixtures
- Standard Material: Low Carbon Steel
- Standard Finish: Bright
- Hallmarking: "CS" and "USA"
- Proof Tested
- Design Factor: 4 to 1
- Packaged in Cartons, Order Unit is "Feet"
- Made in the USA
- Do Not Use for Overhead Lifting
- DO NOT EXCEED THE WORKING LOAD LIMIT



Trade Size	Cat. No.	UPC No.	Material Diameter	Inside Length	Inside Width	Finish	Working Load Limit	Feet Per Pkg	Links Per Ft	Weight Per Pkg
6/0	T0336015	020418192876	0.28 in	1.50 in	0.47 in	Bright	2000 lb	100 ft	8	63 lb

Straight Link Machine Chain - Cartons

- Uses: General Utility, Animal, and Farm and Ranch Applications
- Standard Material: Low Carbon Steel
- Standard Finish: Bright and Zinc Plated
- Proof Tested
- Design Factor: 4 to 1
- Packaged in Cartons, Order Unit is "Feet"
- Made in the USA
- Do Not Use for Overhead Lifting
- DO NOT EXCEED THE WORKING LOAD LIMIT



Trade Size	Finish		UPC No.	UPC No.	Material Diameter	Inside Length	Inside Width	Working Load Limit	Feet Per Pkg	Links Per Ft	Weight Per Pkg
	Zinc Plated	Bright									
Cat. No.	UPC No.	Cat. No.	UPC No.								
4	T0310424	060908	—	—	0.12 in	0.55 in	0.21 in	215 lb	100 ft	21.8	11 lb
3	T0310324	060878	—	—	0.14 in	0.59 in	0.24 in	270 lb	100 ft	20.3	15 lb
2	T0310224	060847	—	—	0.15 in	0.61 in	0.26 in	325 lb	100 ft	19.7	19 lb
1	T0310124	060816	—	—	0.16 in	0.63 in	0.28 in	390 lb	100 ft	19.0	23 lb
1/0	T0311024	060946	—	—	0.18 in	0.74 in	0.31 in	465 lb	100 ft	16.2	27 lb
2/0	T0312024	060984	T0312014	060977	0.18 in	0.78 in	0.34 in	545 lb	100 ft	15.4	29 lb
3/0	T0313024	061011	—	—	0.21 in	1.01 in	0.36 in	635 lb	100 ft	11.9	37 lb
4/0	T0314024	061042	—	—	0.23 in	1.03 in	0.38 in	700 lb	100 ft	11.7	47 lb
5/0	T0315024	061080	T0315014	061073	0.25 in	1.07 in	0.44 in	925 lb	100 ft	11.2	52 lb



CHAIN

Straight Link Machine Chain - Reels

- Uses: General Utility, Animal, and Farm and Ranch Applications
- Standard Material: Low Carbon Steel
- Proof Tested
- Design Factor: 4 to 1
- Packaged on Reels, Order Unit is "Each"
- Made in the USA
- Do Not Use for Overhead Lifting
- DO NOT EXCEED THE WORKING LOAD LIMIT



Trade Size	Cat. No.	UPC No.	Material Diameter	Inside Length	Inside Width	Finish	Working Load Limit	Feet Per Pkg	Links Per Ft	Reel Width	Weight Per Pkg
4	AW0310427	020418145384	0.12 in	0.55 in	0.21 in	Zinc Plated	215 lb	100 ft	22	3.5 in	12 lb
3	T0723367	020418064814	0.14 in	0.59 in	0.24 in	Brass Glo	270 lb	50 ft	20	3.5 in	9 lb
2	T0726727	020418184475	0.15 in	0.61 in	0.26 in	Zinc Plated	325 lb	125 ft	19.7	10.75 in	26 lb

Twist Link Machine Chain - Cartons

- Uses: General Utility Applications
- Standard Material: Low Carbon Steel
- Design Factor: 4 to 1
- Packaged in Cartons, Order Unit is "Feet"
- Made in the USA
- Do Not Use for Overhead Lifting
- DO NOT EXCEED THE WORKING LOAD LIMIT



Trade Size	Cat. No.	UPC No.	Material Diameter	Inside Length	Inside Width	Finish	Working Load Limit	Feet Per Package	Links Per Foot	Weight Per Pkg
3	T0320324	020418061165	0.14 in	0.56 in	0.20 in	Zinc Plated	255 lb	100 ft	21.4	16 lb
2	T0320224	020418061134	0.15 in	0.58 in	0.21 in	Zinc Plated	310 lb	100 ft	20.7	20 lb
1/0	T0321024	020418061219	0.18 in	0.68 in	0.26 in	Zinc Plated	440 lb	100 ft	17.6	28 lb
4/0	T0324024	020418061301	0.23 in	0.89 in	0.32 in	Zinc Plated	670 lb	100 ft	13.5	48 lb

Twist Link Machine Chain - Reels

- Uses: General Utility Applications
- Standard Material: Low Carbon Steel
- Design Factor: 4 to 1
- Packaged on Reels, Order Unit is "Each"
- Made in the USA
- Do Not Use for Overhead Lifting
- DO NOT EXCEED THE WORKING LOAD LIMIT



Trade Size	Cat. No.	UPC No.	Material Diameter	Inside Length	Inside Width	Finish	Working Load Limit	Feet Per Pkg	Links Per Ft	Reel Width	Weight Per Pkg
4	AW0320427	020418145391	0.12 in	0.52 in	0.17 in	Zinc Plated	205 lb	100 ft	23.0	3.5 in	13 lb
2	T0726627	020418184468	0.15 in	0.58 in	0.21 in	Zinc Plated	310 lb	125 ft	20.7	5.5 in	27 lb
2/0	T0722527	020418183300	0.18 in	0.73 in	0.28 in	Zinc Plated	520 lb	70 ft	16.0	5.5 in	21 lb



Twist Link Machine Chain - Square Pails

- Uses: General Utility Applications
- Standard Material: Low Carbon Steel
- Design Factor: 4 to 1
- Packaged in Pails, Order Unit is "Each"
- Made in the USA
- Do Not Use for Overhead Lifting
- DO NOT EXCEED THE WORKING LOAD LIMIT



Trade Size	Cat. No.	UPC No.	Material Diameter	Inside Length	Inside Width	Finish	Working Load Limit	Feet Per Pkg	Links Per Ft	Weight Per Pkg
2/0	T0322026	020418183171	0.18 in	0.73 in	0.28 in	Zinc Plated	520 lb	175 ft	16.4	54 lb

Straight Link Coil Chain - Cartons

- Typical Uses Include Tailgates, Barrier Guards, Swing Sets, Hanging Light Fixtures and Animal Chains
- Standard Material: Low Carbon Steel
- Proof Tested
- Design Factor: 4 to 1
- Packaged in Cartons, Order Unit is "Feet"
- Do Not Use for Overhead Lifting
- DO NOT EXCEED THE WORKING LOAD LIMIT



Trade Size	Cat. No.	UPC No.	Material Diameter	Inside Length	Inside Width	Finish	Working Load Limit	Feet Per Pkg	Links Per Ft	Weight Per Pkg
4	T0330424	020418061455	0.12 in	1.11 in	0.21 in	Zinc Plated	205 lb	100 ft	10.8	10 lb
2	T0330224	020418061394	0.15 in	1.18 in	0.26 in	Zinc Plated	310 lb	100 ft	10.2	15 lb
1	T0330124	020418061363	0.16 in	1.25 in	0.28 in	Zinc Plated	370 lb	100 ft	9.6	19 lb
1/0	T0331024	020418061516	0.18 in	1.25 in	0.31 in	Zinc Plated	440 lb	100 ft	9.6	22 lb
2/0	T0332024	020418061578	0.18 in	1.29 in	0.34 in	Zinc Plated	520 lb	100 ft	9.3	24 lb
3/0	T0333024	020418061622	0.21 in	1.30 in	0.36 in	Zinc Plated	605 lb	100 ft	9.2	31 lb
4/0	T0334024	020418061660	0.22 in	1.39 in	0.49 in	Zinc Plated	670 lb	100 ft	8.6	35 lb
5/0	T0335024	020418061721	0.234 in	1.52 in	0.44 in	Zinc Plated	880 lb	100 ft	7.9	41 lb

Straight Link Coil Green Sleeve Chain - Reels

- Used as Swing Set Chain
- Standard Material: Low Carbon Steel
- Proof Tested
- Design Factor: 4 to 1
- Packaged on Reels, Order Unit is "Each"
- Do Not Use for Overhead Lifting
- DO NOT EXCEED THE WORKING LOAD LIMIT



Trade Size	Cat. No.	UPC No.	Material Diameter	Inside Length	Inside Width	Finish	Working Load Limit	Feet Per Pkg	Links Per Ft	Reel Width	Weight Per Pkg
2/0	PS0332027	020418208997	0.19 in	1.30 in	0.30 in	Zinc Plated with Green Sleeve	520 lb	60 ft	9.3	10.75 in	21 lb



Straight Link Coil Chain - Reels

- Typical Uses Include Tailgates, Barrier Guards, Swing Sets, Hanging Light Fixtures and Animal Chains
- Standard Material: Low Carbon Steel
- Standard Finish: Zinc Plated and Yellow Polycoated
- Proof Tested
- Design Factor: 4 to 1
- Packaged on Reels, Order Unit is "Each"
- Made in the USA
- Do Not Use for Overhead Lifting
- DO NOT EXCEED THE WORKING LOAD LIMIT



Trade Size	Finish		Material Diameter	Inside Length	Inside Width	Working Load Limit	Feet Per Pkg	Links Per Ft	Reel Width	Weight Per Pkg		
	Zinc Plated	Yellow Polycoat										
4	AW0330427	145445	—	—	0.12 in	1.11 in	0.21 in	205 lb	100 ft	10.8	3.5 in	11 lb
2	T0726827	184482	—	—	0.15 in	1.18 in	0.26 in	310 lb	125 ft	10.2	10.75 in	21 lb
2/0	T0722827	183843	—	—	0.18 in	1.29 in	0.34 in	520 lb	40 ft	9.3	3.5 in	14 lb
2/0	T0723627	064869	—	—	0.18 in	1.29 in	0.34 in	520 lb	125 ft	9.3	10.75 in	37 lb
2/0	—	—	PD0722627	183409	0.18 in	1.29 in	0.34 in	520 lb	120 ft	9.3	10.75 in	35 lb
3/0	T0724527	175732	—	—	0.21 in	1.30 in	0.36 in	605 lb	100 ft	9.2	10.75 in	31 lb

Straight Link Coil Chain - Round Pails

- Typical Uses Include Tailgates, Barrier Guards, Swing Sets, Hanging Light Fixtures and Animal Chains
- Standard Material: Low Carbon Steel
- Standard Finish: Zinc Plated
- Proof Tested
- Design Factor: 4 to 1
- Packaged in Pails, Order Unit is "Each"
- Made in the USA
- Do Not Use for Overhead Lifting
- DO NOT EXCEED THE WORKING LOAD LIMIT



Trade Size	Cat. No.	UPC No.	Material Diameter	Inside Length	Inside Width	Finish	Working Load Limit	Feet Per Pkg	Links Per Ft	Weight Per Pkg
2/0	T0332023	020418061561	0.18 in	1.29 in	0.34 in	Zinc Plated	520 lb	400 ft	9.3	97 lb



Straight Link Coil Chain - Square Pails

- Typical Uses Include Tailgates, Barrier Guards, Swing Sets, Hanging Light Fixtures and Animal Chains
- Standard Material: Low Carbon Steel
- Proof Tested
- Design Factor: 4 to 1
- Packaged in Pails, Order Unit is "Each"
- Made in the USA
- Do Not Use for Overhead Lifting
- DO NOT EXCEED THE WORKING LOAD LIMIT



Trade Size	Cat. No.	UPC No.	Material Diameter	Inside Length	Inside Width	Finish	Working Load Limit	Feet Per Pkg	Links Per Ft	Weight Per Pkg
1	T0330126	020418187643	0.16 in	1.25 in	0.28 in	Zinc Plated	370 lb	350 ft	9.6	66 lb
1/0	T0331026	020418187667	0.18 in	1.25 in	0.31 in	Zinc Plated	440 lb	250 ft	9.6	55 lb
2/0	T0332426	020418183188	0.18 in	1.29 in	0.34 in	Zinc Plated	520 lb	225 ft	9.3	55 lb
5/0	T0335026	020418187674	0.234 in	1.52 in	0.44 in	Zinc Plated	880 lb	140 ft	7.9	58 lb

Twist Link Coil Chain - Cartons

- Typical Uses Include Tailgates, Barrier Guards, Light Fixtures and Animal Chains
- Difference Over Straight Link is Twist Link Chain Lies Flat
- Standard Material: Low Carbon Steel
- Design Factor: 4 to 1
- Packaged in Cartons, Order Unit is "Feet"
- Made in the USA
- Do Not Use for Overhead Lifting
- DO NOT EXCEED THE WORKING LOAD LIMIT



Trade Size	Cat. No.	UPC No.	Material Diameter	Inside Length	Inside Width	Finish	Working Load Limit	Feet Per Pkg	Links Per Ft	Weight Per Pkg
3	T0340324	020418061868	0.14 in	1.14 in	0.21 in	Zinc Plated	240 lb	100 ft	10.5	13 lb

Twist Link Coil Chain - Reels

- Typical Uses Include Tailgates, Barrier Guards, Light Fixtures and Animal Chains
- Difference Over Straight Link is Twist Link Chain Lies Flat
- Standard Material: Low Carbon Steel
- Design Factor: 4 to 1
- Packaged on Reels, Order Unit is "Each"
- Made in the USA
- Do Not Use for Overhead Lifting
- DO NOT EXCEED THE WORKING LOAD LIMIT



Trade Size	Cat. No.	UPC No.	Material Diameter	Inside Length	Inside Width	Finish	Working Load Limit	Feet Per Pkg	Links Per Ft	Reel Width	Weight Per Pkg
3	T0723167	020418064777	0.14 in	1.14 in	0.21 in	Brass Glo	240 lb	50 ft	10.5	3.5 in	7.5 lb

Passing Link Chain - Cartons

- Uses: General Utility, Animal, and Farm and Ranch Applications
- Standard Material: Low Carbon Steel
- Standard Finish: Zinc Plated
- Proof Tested
- Design Factor: 4 to 1
- Packaged in Cartons, Order Unit is "Feet"
- Made in the USA
- Do Not Use for Overhead Lifting
- DO NOT EXCEED THE WORKING LOAD LIMIT



Trade Size	Cat. No.	UPC No.	Material Diameter	Inside Length	Inside Width	Finish	Working Load Limit	Feet Per Pkg	Links Per Ft	Weight Per Pkg
4/0	T0304024	020418060786	0.22 in	0.88 in	0.50 in	Zinc Plated	600 lb	100 ft	13.8	43 lb

Passing Link Chain - Reels

- Uses: General Utility, Animal, and Farm and Ranch Applications
- Standard Material: Low Carbon Steel
- Standard Finish: Zinc Plated
- Proof Tested
- Design Factor: 4 to 1
- Packaged on Reels, Order Unit is "Each"
- Made in the USA
- Do Not Use for Overhead Lifting
- DO NOT EXCEED THE WORKING LOAD LIMIT



Trade Size	Cat. No.	UPC No.	Material Diameter	Inside Length	Inside Width	Finish	Working Load Limit	Feet Per Pkg	Links Per Ft	Reel Width	Weight Per Pkg
2/0	T0722927	020418183317	0.18 in	0.88 in	0.47 in	Zinc Plated	450 lb	125 ft	13.75	10.75 in	36 lb
2/0	T0722957	020418183478	0.18 in	0.88 in	0.47 in	Zinc Plated	450 lb	50 ft	13.75	5.5 in	15 lb

Passing Link Chain - Square Pails

- Uses: General Utility, Animal, and Farm and Ranch Applications
- Standard Material: Low Carbon Steel
- Standard Finish: Zinc Plated
- Proof Tested
- Design Factor: 4 to 1
- Packaged in Pails, Order Unit is "Each"
- Made in the USA
- Do Not Use for Overhead Lifting
- DO NOT EXCEED THE WORKING LOAD LIMIT



Trade Size	Cat. No.	UPC No.	Material Diameter	Inside Length	Inside Width	Finish	Working Load Limit	Feet Per Pkg	Links Per Ft	Weight Per Pkg
2/0	T0309526	020418183164	0.18 in	0.88 in	0.47 in	Zinc Plated	450 lb	200 ft	13.8	58 lb



Handy Link Utility Chain - Square Pails

- For Hanging Fixtures and Plants
- Standard Material: Low Carbon Steel
- Standard Finish: Zinc Plated
- Proof Tested
- Design Factor: 4 to 1
- Packaged in Pails, Order Unit is "Each"
- Made in the USA
- Do Not Use for Overhead Lifting
- DO NOT EXCEED THE WORKING LOAD LIMIT



Trade Size	Cat. No.	UPC No.	Material Diameter	Inside Length	Inside Width	Finish	Working Load Limit	Feet Per Pkg	Links Per Ft	Weight Per Pkg
120	T0339626	020418183195	0.120 in	1.35 in	0.34 in	Zinc Plated	255 lb	500 ft	8.9	50 lb

Handy Link Utility Chain - Reels

- For Hanging Fixtures and Plants
- Standard Material: Low Carbon Steel
- Standard Finish: Zinc Plated
- Proof Tested
- Design Factor: 4 to 1
- Packaged on Reels, Order Unit is "Each"
- Made in the USA
- Do Not Use for Overhead Lifting
- DO NOT EXCEED THE WORKING LOAD LIMIT



Trade Size	Cat. No.	UPC No.	Material Diameter	Inside Length	Inside Width	Finish	Working Load Limit	Feet Per Pkg	Links Per Ft	Reel Width	Weight Per Pkg
120	T0723169	020418064784	0.120 in	1.35 in	0.34 in	Zinc Plated	255 lb	175 ft	8.9	10.75 in	17.5 lb

Lock Link, Single Loop Chain - Cartons

- Ideal for Sprocket Wheel, Overhead Door Chains, General Utility Use
- Standard Material: Low Carbon Steel
- Standard Finish: Zinc Plated, Galvanized
- Design Factor: 4 to 1
- Packaged in Cartons, Order Unit is "Feet"
- Made in the USA
- Do Not Use for Overhead Lifting
- DO NOT EXCEED THE WORKING LOAD LIMIT



Trade Size	Finish		UPC No.	UPC No.	Material Diameter	Inside Length	End Type	Working Load Limit	Feet Per Pkg	Links Per Ft	Weight Per Pkg	
	Zinc Plated	Galvanized										
2	T0740224	066238	020418+	T0740234	066252	0.09 in	1.08 in	Sheared	155 lb	100 ft	11.1	9 lb
1/0	T0741024	066290	T0741034	066320	0.12 in	1.29 in	Wrapped	265 lb	100 ft	9.3	16 lb	

(continued)

Trade Size	Finish		Cat. No.	UPC No. 020418+	Material Diameter	Inside Length	End Type	Working Load Limit	Feet Per Pkg	Links Per Ft	Weight Per Pkg
	Zinc Plated	Galvanized									
	Cat. No.	Cat. No.									
2/0	T0742024	066375	T0742034	066399	0.14 in	1.48 in	Wrapped	340 lb	100 ft	8.1	23 lb
3/0	T0743024	066412	—	—	0.15 in	1.63 in	Wrapped	405 lb	100 ft	7.4	26 lb
4/0	T0744024	066481	—	—	0.16 in	1.80 in	Wrapped	485 lb	100 ft	6.7	29 lb
5/0	T0745024	066566	—	—	0.18 in	2.15 in	Wrapped	580 lb	100 ft	5.6	34 lb

Lock Link, Single Loop Chain - Reels



- Ideal for Sprocket Wheel, Overhead Door Chains, General Utility Use
- Standard Material: Low Carbon Steel
- Standard Finish: Zinc Plated, Galvanized
- Design Factor: 4 to 1
- Packaged on Reels, Order Unit is "Each"
- Made in the USA
- Do Not Use for Overhead Lifting
- DO NOT EXCEED THE WORKING LOAD LIMIT



Trade Size	Finish		Cat. No.	UPC No. 020418+	Material Diameter	Inside Length	End Type	Working Load Limit	Feet Per Pkg	Links Per Ft	Reel Width	Weight Per Pkg
	Galvanized	Zinc Plated										
	Cat. No.	Cat. No.										
2	T0740237	066269	—	—	0.09 in	1.08 in	Sheared	155 lb	360 ft	11.1	10.75 in	33 lb
1/0	T0741037	066337	—	—	0.12 in	1.29 in	Wrapped	265 lb	250 ft	9.3	10.75 in	40 lb
3/0	—	—	T0723427	064845	0.15 in	1.63 in	Wrapped	405 lb	125 ft	7.4	10.75 in	33 lb
3/0	—	—	T0722427	183454	0.15 in	1.63 in	Wrapped	405 lb	50 ft	7.4	5.5 in	17 lb
4/0	T0744037	066528	T0744027	066498	0.16 in	1.80 in	Wrapped	485 lb	100 ft	6.7	10.75 in	29 lb
5/0	T0745037	066603	—	—	0.18 in	2.15 in	Wrapped	580 lb	100 ft	5.6	10.75 in	34 lb

Brass Plumber's Chain - Cartons

- Plumbing Fixtures, & Other Applications Requiring Light Flat Metal Chain
- Standard Material: Brass
- Standard Finish: Bright
- Design Factor: 4 to 1
- Packaged in Cartons, Order Unit is "Feet"
- Do Not Use for Overhead Lifting
- DO NOT EXCEED THE WORKING LOAD LIMIT



Trade Size	Cat. No.	UPC No.	Stock Thickness	Inside Length	Finish	Working Load Limit	Feet Per Pkg	Links Per Ft	Weight Per Pkg	Shelf Pack Qty.
2/0	T0872014N	020418330926	0.02 in	0.55 in	Bright	23 lb	100 ft	21.8	2.2 lb	100
1/0	T0871014N	020418330919	0.02 in	0.55 in	Bright	35 lb	100 ft	21.8	3 lb	100



Brass Plumber's Chain - Reels

- Plumbing Fixtures, & Other Applications Requiring Light Flat Metal Chain
- Standard Material: Brass
- Standard Finish: Bright
- Design Factor: 4 to 1
- Packaged on Reels, Order Unit is "Each"
- Do Not Use for Overhead Lifting
- DO NOT EXCEED THE WORKING LOAD LIMIT



Trade Size	Cat. No.	UPC No.	Material Diameter	Stock Thickness	Inside Length	Finish	Working Load Limit	Feet Per Pkg	Links Per Ft	Reel Width	Weight Per Pkg
1/0	T0723817N	020418330902	.02 in	0.02 in	0.55 in	Bright	35 lb	200 ft	21.8	3.5 in	5 lb

Inco, Double Loop Chain - Cartons

- Farm and Animal Chains, and Many General-Purpose Applications
- Standard Material: Low Carbon Steel
- Standard Finish: Zinc Plated, Galvanized
- Design Factor: 4 to 1
- Packaged in Cartons, Order Unit is "Feet"
- Note: Avoid Twisting in Suspension Applications
- Campbell Recommends The Use of Proof Coil or Straight Link Coil Chain for Swing Set Applications
- Do Not Use for Overhead Lifting
- DO NOT EXCEED THE WORKING LOAD LIMIT



Trade Size	Finish		Cat. No.	UPC No. 020418+	Material Diameter	Inside Length	Working Load Limit	Feet Per Pkg	Links Per Ft	Weight Per Pkg	Shelf Pack
	Zinc Plated	Galvanized									
4	T0750424N	330421	—	—	0.07 in	1.00 in	70 lb	100 ft	12.0	5 lb	100
3	T0750324N	330384	—	—	0.08 in	1.10 in	90 lb	100 ft	10.9	6 lb	-
2	T0750224N	330346	—	—	0.09 in	1.33 in	115 lb	100 ft	9.0	8 lb	-
1	T0750124N	330292	—	—	0.11 in	1.54 in	155 lb	100 ft	7.8	10 lb	100
1/0	—	—	T0751034N	330445	0.12 in	1.78 in	200 lb	100 ft	6.7	13 lb	-
2/0	T0752024N	330513	T0752034N	330469	0.14 in	2.17 in	255 lb	100 ft	5.5	16 lb	-
4/0	—	—	T0754034N	330575	0.16 in	2.19 in	365 lb	100 ft	5.5	25 lb	-
8/0	—	—	T0758034	067167	0.23 in	2.90 in	705 lb	100 ft	4.1	51 lb	-

Inco, Double Loop Chain - Reels

- Farm and Animal Chains, and Many General-Purpose Applications
- Standard Material: Low Carbon Steel
- Standard Finish: Zinc Plated, Polycoated in White, Yellow, or Red Colors
- Design Factor: 4 to 1
- Packaged on Reels, Order Unit is "Each"
- Note: Avoid Twisting in Suspension Applications
- Campbell Recommends The Use of Proof Coil or Straight Link Coil Chain for Swing Set Applications
- Do Not Use for Overhead Lifting
- DO NOT EXCEED THE WORKING LOAD LIMIT



Trade Size	Cat. No.	UPC No.	Material Diameter	Inside Length	Finish	Working Load Limit	Feet Per Pkg	Links Per Ft	Reel Width	Weight Per Pkg
3	T0723227N	020418330407	0.08 in	1.10 in	Zinc Plated	90 lb	200 ft	10.9	5.5 in	14 lb
3	PG0722227N	020418330360	0.08 in	1.10 in	Red Polycoat	90 lb	150 ft	10.9	5.5 in	11 lb
2	T0750227N	020418330353	0.09 in	1.33 in	Zinc Plated	115 lb	250 ft	9.0	10.75 in	21 lb
1	T0720127N	020418330322	0.11 in	1.54 in	Zinc Plated	155 lb	250 ft	7.8	10.75 in	27.60 lb
1	T0722627N	020418330308	0.11 in	1.54 in	Zinc Plated	155 lb	125 ft	7.8	5.5 in	14 lb
1/0	AW0751024N	020418330438	0.12 in	1.78 in	Zinc Plated	200 lb	100 ft	6.7	5.5 in	13 lb
2/0	PA0722027N	020418330476	0.14 in	2.17 in	White Polycoat	255 lb	125 ft	5.5	10.75 in	22 lb
2/0	PD0722027N	020418330483	0.14 in	2.17 in	YellowPolycoat	255 lb	125 ft	5.5	10.75 in	23 lb
2/0	PD0722087N	020418330506	0.14 in	2.17 in	YellowPolycoat	255 lb	50 ft	5.5	5.5 in	10 lb
2/0	T0722027N	020418330537	0.14 in	2.17 in	Zinc Plated	255 lb	155 ft	5.5	10.75 in	26 lb
2/0	T0722087N	020418330568	0.14 in	2.17 in	Zinc Plated	255 lb	60 ft	5.5	5.5 in	11 lb
3/0	T0726427N	020418330285	0.15 in	2.17 in	Zinc Plated	305 lb	150 ft	5.5	10.75 in	34 lb
4/0	T0724627N	020418330599	0.16 in	2.19 in	Zinc Plated	365 lb	100 ft	5.5	10.75 in	28 lb

Inco, Double Loop Chain - Round Pails

- Farm and Animal Chains, and Many General-Purpose Applications
- Standard Material: Low Carbon Steel
- Standard Finish: Zinc Plated
- Design Factor: 4 to 1
- Packaged in Pails, Order Unit is "Each"
- Note: Avoid Twisting in Suspension Applications
- Campbell Recommends The Use of Proof Coil or Straight Link Coil Chain for Swing Set Applications
- Do Not Use for Overhead Lifting
- DO NOT EXCEED THE WORKING LOAD LIMIT



Trade Size	Cat. No.	UPC No.	Material Diameter	Inside Length	Finish	Working Load Limit	Feet Per Pkg	Links Per Ft	Weight Per Pkg
2/0	T0752023N	020418330551	0.14 in	2.17 in	Zinc Plated	255 lb	350 ft	5.5	56 lb



Inco, Double Loop Chain - Square Pails

- Farm and Animal Chains, and Many General-Purpose Applications
- Standard Material: Low Carbon Steel
- Standard Finish: Zinc Plated and Yellow Polycoated
- Design Factor: 4 to 1
- Packaged in Pails, Order Unit is "Each"
- Note: Avoid Twisting in Suspension Applications
- Campbell Recommends The Use of Proof Coil or Straight Link Coil Chain for Swing Set Applications
- Do Not Use for Overhead Lifting
- DO NOT EXCEED THE WORKING LOAD LIMIT



Trade Size	Cat. No.	UPC No.	Material Diameter	Inside Length	Finish	Working Load Limit	Feet Per Package	Links Per Foot	Weight Per Package
3	T0754326N	020418330414	0.08 in	1.10 in	Zinc Plated	90 lb	750 ft	10.9	47 lb
1	T0754126N	020418330339	0.11 in	1.54 in	Zinc Plated	155 lb	450 ft	7.8	45 lb
2/0	T0752426N	020418330544	0.14 in	2.17 in	Zinc Plated	255 lb	275 ft	5.5	50 lb
2/0	PD0752496N	020418330490	0.14 in	2.17 in	Yellow Polycoat	255 lb	200 ft	5.5	36 lb

Special Inco Well Chain

- General Utility; Farm and Animal; Well Pipes
- Standard Material: Low Carbon Steel, Galvanized Wire
- Packaged in Cartons, Order Unit is "Feet" or Pail, Order Unit is "Each"
- Do Not Use for Overhead Lifting
- DO NOT EXCEED THE WORKING LOAD LIMIT



Trade Size	Cat. No.	UPC No.	Material Diameter	Inside Length	Finish	Working Load Limit	Feet Per Pkg	Links Per Ft	Weight Per Pkg
2/0	T0762024N	020418330605	0.14 in	2.50 in	Zinc Plated	255 lb	250 ft	5.5	43 lb
2/0	T0762026N	020418330612	0.14 in	2.50 in	Zinc Plated	255 lb	250 ft	5.5	41 lb

Single Jack Chain - Cartons

- Fixture and Novelty Suspension
- General Utility Use Not Requiring High Strength
- Standard Material: Low Carbon Steel
- Standard Finish: Zinc Plated
- Packaged in Cartons, Order Unit is "Feet"
- Do Not Use for Overhead Lifting
- DO NOT EXCEED THE WORKING LOAD LIMIT



Trade Size	Cat. No.	UPC No.	Material Diameter	Inside Length	Finish	Working Load Limit	Feet Per Pkg	Links Per Ft	Weight Per Pkg	Shelf Pack
16	T0801624N	020418330773	0.06 in	0.63 in	Zinc Plated	10 lb	100 ft	24	3 lb	100
14	T0801424N	020418330735	0.08 in	0.63 in	Zinc Plated	16 lb	100 ft	19	5 lb	100
12	T0801224N	020418330698	0.11 in	0.75 in	Zinc Plated	29 lb	100 ft	16	9 lb	

(continued)

Trade Size	Cat. No.	UPC No.	Material Diameter	Inside Length	Finish	Working Load Limit	Feet Per Pkg	Links Per Ft	Weight Per Pkg	Shelf Pack
10	T0801024N	020418330667	0.14 in	0.93 in	Zinc Plated	43 lb	100 ft	13	14 lb	
8	T0800824N	020418330797	0.16 in	1.09 in	Zinc Plated	60 lb	100 ft	11	21 lb	

Single Jack Chain - Reels

- Fixture and Novelty Suspension
- General Utility Use Not Requiring High Strength
- Standard Material: Low Carbon Steel
- Standard Finish: Zinc Plated and Black Polycoated
- Packaged on Reels, Order Unit is "Each"
- Do Not Use for Overhead Lifting
- DO NOT EXCEED THE WORKING LOAD LIMIT



Trade Size	Cat. No.	UPC No.	Material Diameter	Inside Length	Finish	Working Load Limit	Feet Per Pkg	Links Per Foot	Reel Width	Weight Per Pkg
16	T0724027N	020418330780	0.06 in	0.50 in	Zinc Plated	10 lb	250 ft	24	3.5 in	8 lb
14	PB0722827N	020418330728	0.08 in	0.63 in	Black Polycoat	16 lb	190 ft	19	3.5 in	10 lb
14	AW0801427N	020418330742	0.08 in	0.63 in	Zinc Plated	16 lb	200 ft	19	3.5 in	12 lb
12	T0721727N	020418330704	0.11 in	0.75 in	Zinc Plated	29 lb	100 ft	16	3.5 in	9 lb
12	AW0801227N	020418330681	0.11 in	0.75 in	Zinc Plated	29 lb	200 ft	16	5.5 in	17 lb
10	AW0801027N	020418330674	0.14 in	0.93 in	Zinc Plated	43 lb	100 ft	13	5.5 in	15 lb

Double Jack Chain - Reels

- Fixture and Novelty Suspension
- General Utility Use Not Requiring High Strength
- Standard Material: Low Carbon Steel
- Standard Finish: Zinc Plated, Brass Glo
- Design Factor: 4 to 1
- Do Not Use for Overhead Lifting
- DO NOT EXCEED THE WORKING LOAD LIMIT



Trade Size	Finish		UPC No.	UPC No.	Material Diameter	Inside Length	Working Load Limit	Feet Per Pkg	Links Per Ft	Reel Width	Weight Per Pkg
	Zinc Plated	Brass Glo									
16	T0721627N	330766	020418+	020418+	0.06 in	0.34 in	11 lb	200 ft	35	3.5 in	8 lb



Sash Chain - Cartons

- Counter-Balance Chain for Double Hung Window Sashes
- Also for Arc Lamp Chain, Animal Chain
- Standard Material: Low Carbon Steel
- Standard Finish: Zinc Plated, Copper Glo, Solid Bronze
- Design Factor: 4 to 1
- Packaged in Cartons, Order Unit is "Feet"
- Do Not Use for Overhead Lifting
- DO NOT EXCEED THE WORKING LOAD LIMIT



Trade Size	Finish						Stock Thickness	Inside Length	Working Load Limit	Feet Per Pkg	Links Per Ft	Weight Per Pkg	Shelf Pack
	Zinc Plated	Copper Glo		Solid Bronze									
Cat. No.	UPC No. 020418+	Cat. No.	UPC No. 020418+	Cat. No.	UPC No. 020418+								
8	T0890824N	330964	—	—	—	0.04 in	0.55 in	75 lb	100 ft	22	4 lb	100	
8	—	—	T0880844N	330957	—	0.04 in	0.55 in	75 lb	100 ft	22	5 lb	1	
25	T0892524N	330988	—	—	—	0.04 in	0.55 in	94 lb	100 ft	22	5 lb	100	
35	T0893524N	330995	T0893544N	331008	—	0.04 in	0.59 in	106 lb	100 ft	20	6 lb	100	
35	—	—	—	—	T0893574N	331015	0.04 in	0.59 in	100 lb	100 ft	8 lb	100	
40	T0894024N	331022	—	—	—	0.04 in	0.59 in	131 lb	100 ft	20	8 lb	-	
40	—	—	T0894044N	331039	—	0.04 in	0.59 in	131 lb	100 ft	20	7 lb	-	
40	—	—	—	—	T0894074N	331046	0.04 in	0.59 in	125 lb	100 ft	7 lb	100	

Stainless Steel Sash Chain - Cartons

- Counter-Balance Chain for Double Hung Window Sashes
- Also for Arc Lamp Chain, Animal Chain
- Standard Material: Type 304 Stainless Steel
- Standard Finish: Polished
- Design Factor: 4 to 1
- Packaged in Cartons, Order Unit is "Feet"
- Do Not Use for Overhead Lifting
- DO NOT EXCEED THE WORKING LOAD LIMIT



Trade Size	Cat. No.	UPC No.	Stock Thickness)	Inside Length	Finish	Working Load Limit	Feet Per Pkg	Links Per Ft	Weight Per Pkg
8	T0898014N	020418331077	0.04 in	0.55 in	Polished	75 lb	100 ft	22	4 lb
35	T0895314N	020418331060	0.04 in	0.59 in	Polished	175 lb	100 ft	20	6 lb

Sash Chain - Reels

- Counter-Balance Chain for Double Hung Window Sashes
- Also for Arc Lamp Chain, Animal Chain
- Standard Material: Low Carbon Steel
- Standard Finish: Zinc Plated
- Design Factor: 4 to 1
- Packaged on Reels, Order Unit is "Each"
- Do Not Use for Overhead Lifting
- DO NOT EXCEED THE WORKING LOAD LIMIT



Trade Size	Cat. No.	UPC No.	Material Diameter	Stock Thickness	Inside Length	Finish	Working Load Limit	Feet Per Pkg	Links Per Ft	Reel Width	Weight Per Pkg
35	T0723727N	020418330940	.04 in	0.04 in	0.59 in	Zinc Plated	106 lb	100 ft	20	3.5 in	7 lb

Decorator Chain - Reels

- For Hanging Plants and Lamps, Drapery Tie-Backs
- Finishes: Zinc Plated, Brass Glo, Black Polycoated, Antique Brass, White Polycoated, Antique Copper, Antique Silver, Brushed Nickel
- Order Unit is "Each Reel"
- DO NOT EXCEED THE WORKING LOAD LIMIT



Trade Size	Cat. No.	UPC No.	Material Diameter	Inside Length	Inside Width	Finish	Working Load Limit	Feet Per Pkg	Reel Width	Weight Per Pkg	Shelf Pack
4	T0720428N	020418330858	.135 in	.59 in	.2 in	Zinc Plated	70 lb	90 ft	3.5 in	10 lb	
10	T0722000	020418190834	0.135 in	1.21 in	0.52 in	Brass Glo	35 lb	60 ft	3.5 in	10 lb	1
10	T0722002N	020418330803	0.135 in	1.2 in	.51 in	Black Polycoat	35 lb	40 ft	3.5 in	6.8 lb	
10	T0722003N	020418330827	0.135 in	1.21 in	0.52 in	Antique Brass	35 lb	40 ft	3.5 in	6.8 lb	
10	T0722004N	020418330810	0.135 in	1.24 in	0.52 in	White Polycoat	35 lb	40 ft	3.5 in	6.8 lb	
10	T0722006N	020418330834	0.135 in	1.21 in	0.52 in	Antique Copper	35 lb	40 ft	3.5 in	6.8 lb	
10	T0722007N	020418330841	0.135 in	1.21 in	0.52 in	Antique Silver	35 lb	40 ft	3.5 in	6.8 lb	
10	T0722010	020418212161	0.135 in	1.21 in	0.52 in	Brushed Nickel	35 lb	40 ft	3.5 in	6.8 lb	



Hobby/Craft Twist Chain - Mini Reels

- Used for Decorative and Hobby/Craft Applications
- Finishes: Brass Plated, Nickel Plated, Black
- Order Unit is "Each Reel"
- DO NOT EXCEED THE WORKING LOAD LIMIT



Trade Size	Finish		Nickel Plated		Material Diameter	Inside Length	Inside Width	Working Load Limit	Feet Per Pkg	Reel Width	Weight Per Pkg
	Brass Plated		Cat. No.	UPC No. 020418+							
70	T0717017	188558	—	—	0.043 in	0.14 in	0.07 in	5 lb	82 ft	3.25 in	1.5 lb
90	—	—	T0719027	188589	0.056 in	0.21 in	0.12 in	5 lb	82 ft	3.25 in	2 lb
200	T0712017	188282	—	—	0.079 in	0.40 in	0.16 in	12 lb	49 ft	3.25 in	2.8 lb

Hobby/Craft Clock Chain - Mini Reels

- Used for Decorative and Hobby/Craft Applications
- Finishes: Brass Plated
- Order Unit is "Each Reel"
- DO NOT EXCEED THE WORKING LOAD LIMIT



Trade Size	Cat. No.	UPC No.	Material Diameter	Inside Length	Inside Width	Finish	Working Load Limit	Feet Per Pkg	Reel Width	Weight Per Pkg
3	T0710317	020418188183	0.043 in	0.31 in	0.11 in	Brass Plated	5 lb	164 ft	3.25 in	2.8 lb
5	T0710517	020418188206	0.051 in	0.31 in	0.11 in	Brass Plated	10 lb	82 ft	3.25 in	1.8 lb
7	T0710717	020418188220	0.063 in	0.30 in	0.11 in	Brass Plated	15 lb	82 ft	3.25 in	2.5 lb

Hobby/Craft Sash Chain - Mini Reels

- Used for Decorative and Hobby/Craft Applications
- Finishes: Chrome Plated
- Order Unit is "Each Reel"
- DO NOT EXCEED THE WORKING LOAD LIMIT



Trade Size	Cat. No.	UPC No.	Material Diameter	Inside Length	Inside Width	Finish	Working Load Limit	Feet Per Pkg	Reel Width	Weight Per Pkg
2	T0710227	020418188176	0.016 in	0.58 in	0.20 in	Chrome Plated	29 lb	164 ft	3.25 in	2.1 lb
3	T0713027	020418188367	0.020 in	0.75 in	0.27 in	Chrome Plated	25 lb	82 ft	3.25 in	1.8 lb

Oval Link Chain

- Used for Decorative and Hobby/Craft Applications
- Finishes: Brass Plated
- Order Unit is "Each Reel"
- DO NOT EXCEED THE WORKING LOAD LIMIT



Trade Size	Cat. No.	UPC No.	Material Diameter	Inside Length	Inside Width	Finish	Working Load Limit	Feet Per Pkg	Reel Width	Weight Per Pkg
19	T0711917	020418188275	0.043 in	0.20 in	0.11 in	Brass Plated	3 lb	82 ft	3.25 in	1.70 lb

Plastic Chain - Square Pails

- Used for Creating Borders for Flower Beds, Gardens, Driveways, Etc.
- For Decorative Non-Load Bearing Use Only
- Available in Three Colors: White, Yellow or Black
- Order Unit is "Each Pail"
- Do Not Use for Overhead Lifting, Towing or Pulling



Trade Size	Color			Material Diameter	Inside Length	Inside Width	Feet Per Pkg	Weight Per Pkg			
	White	Yellow	Black								
Cat. No.	UPC No. 020418+	Cat. No.	UPC No. 020418+	Cat. No.	UPC No. 020418+						
8	T0990846	185205	T0990836	185182	T0990856	185229	0.29 in	1.50 in	0.40 in	138 ft	12 lb

Plastic Chain - Reels

- Used for Creating Borders for Flower Beds, Gardens, Driveways, Etc.
- For Decorative Non-Load Bearing Use Only
- Available in Three Colors: White, Yellow or Black
- Order Unit is "Each Reel"
- Do Not Use for Overhead Lifting, Towing or Pulling



Trade Size	Color			Material Diameter	Inside Length	Inside Width	Feet Per Pkg	Reel Width	Weight Per Pkg			
	White	Yellow	Black									
Cat. No.	UPC No. 020418+	Cat. No.	UPC No. 020418+	Cat. No.	UPC No. 020418+							
8	T0990847	185212	T0990837	185199	T0990857	185236	0.30 in	1.50 in	0.50 in	60 ft	10.75 in	5 lb



Cable - Uncoated, Galvanized

- High Strength Cable with A Galvanized Finish
- Flexible 7 X 7 or 7 X 19 Construction
- Design Factor: 5 to 1
- DO NOT EXCEED THE WORKING LOAD LIMIT

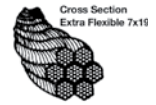

Cat. No.	UPC No.	Size (in)	Construction Type	Working Load Limit	Feet Per Pkg	Reel Width	Weight Per Pkg
7000227	020418100253	1/16	7 x 7	96 lb	500 ft	3.5 in	5 lb
7000327	020418100260	3/32	7 x 7	184 lb	500 ft	3.5 in	14 lb
7000427	020418100284	1/8	7 x 7	340 lb	500 ft	3.5 in	16 lb
7000627	020418100307	3/16	7 x 19	840 lb	250 ft	3.5 in	18 lb
7000827	020418100321	1/4	7 x 19	1400 lb	250 ft	6 in	26 lb
7000927	020418189463	5/16	7 x 19	1960 lb	200 ft	6 in	35 lb

Cable - Vinyl Coated

- High Strength Cable with A Galvanized Finish
- Clear Vinyl Coated
- Flexible 7 X 7 or 7 X 19 Construction
- Vinyl Coated Cable is More Resistant to Abrasion and Weathering
- Can Be Cleaned Easily
- Warning: Remove Plastic Coating From Cable Where Clips, Clamps, Ferrules or Hardware Are Attached
- Design Factor: 5 to 1
- DO NOT EXCEED THE WORKING LOAD LIMIT



Cat. No.	UPC No.	Size	Size w/ Coating	Construction Type	Color	Working Load Limit	Feet Per Pkg	Reel Width	Weight Per Pkg
7000397	020418100277	3/32 in	3/16 in	7 x 7	Clear	184 lb	250 ft	3.5 in	8 lb
7000497	020418100291	1/8 in	3/16 in	7 x 7	Clear	340 lb	250 ft	3.5 in	10 lb
7000697	020418100314	3/16 in	1/4 in	7 x 19	Clear	840 lb	250 ft	6 in	20 lb
7000797	020418289309	3/16 in	1/4 in	7 x 19	Hi-Viz Orange	840 lb	250 ft	6 in	20 lb
7000897	020418100338	1/4 in	5/16 in	7 x 19	Clear	1400 lb	200 ft	6 in	26 lb

Cable - Coated Green

- Green Vinyl Coated Cable
- 1 X 7 Iron Wire Construction Which Enables Bending or Shaping of Cable
- Vinyl Coated Cable is More Resistant to Abrasion and Weathering
- Can Be Cleaned Easily
- Warning: Remove Plastic Coating From Cable Where Clips, Clamps, Ferrules or Hardware Are Attached
- Design Factor: 5 to 1
- DO NOT EXCEED THE WORKING LOAD LIMIT



Cat. No.	UPC No.	Size (in)	Size With Coating	Construction Type	Working Load Limit	Feet Per Pkg	Reel Width	Weight Per Pkg
7000197	020418189456	1/16	1/8 in	1 x 7	28 lb	250 ft	3.5 in	5 lb

Cable - Stainless Steel

- High Strength Stainless Steel Cable
- Type 304 Stainless Steel
- Flexible 7 X 7 or 7 X 19 Construction
- Design Factor: 5 to 1
- DO NOT EXCEED THE WORKING LOAD LIMIT

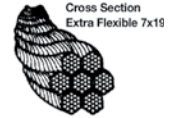

Cat. No.	UPC No.	Size (in)	Construction Type	Working Load Limit	Feet Per Pkg	Reel Width	Weight Per Pkg
T7000226	020418240775	1/16	7 x 7	96 lb	250 ft	3.5 in	2.3 lb
T7000326	020418240782	3/32	7 x 7	184 lb	250 ft	3.5 in	6.3 lb
7000426	020418193071	1/8	7 x 7	340 lb	250 ft	3.5 in	7.2 lb
7000626	020418193088	3/16	7 x 19	740 lb	250 ft	3.5 in	16 lb
7000826	020418193095	1/4	7 x 19	1280 lb	250 ft	6 in	26 lb

Construction Chain

- Manufactured Using Grade 30 Proof Coil Chain
- Self Colored Finish
- General Purpose Chain Primarily Used in Telecommunications Industry for Tying, Binding and Pulling; Outside the Plant
- Order unit is "Each"
- Made in the USA
- Do Not Use for Overhead Lifting
- DO NOT EXCEED THE WORKING LOAD LIMIT



Cat. No.	UPC No.	Size/Trade Size	Weight Each	Working Load Limit
T0213505	020418178405	5/16 in x 4-1/3 ft.	6 lb	1700 lb

Log Chain

- Made From Grade 30 Proof Coil Chain with Grab Hook One End, Slip Hook Other End
- Standard Finish: Self Colored
- Proof Tested
- Design Factor: 4 to 1
- Packed One 14 Ft. Length Per Bag; 2 Bags Per Box
- Made in the USA
- Do Not Use for Overhead Lifting
- DO NOT EXCEED THE WORKING LOAD LIMIT



Trade Size Fractional	Cat. No.	UPC No.	Length	Weight Each	Working Load Limit	Shelf Pack
3/8 in	1005505	020418068591	14 ft	23 lb	2650 lb	2



Grade 43, Binder Chains



- Binder Chains Manufactured Using Grade 43 Chain and Feature Forged Heat Treated Clevis Grab Hooks on Each End
- Standard Finish: Bright (Brt)
- Chains May Be Used in Accordance with Latest D.O.T. Regulations
- Used to Tie Down or "Bind" Loads for Transportation
- Packaged in Drums, Order Unit is "Each"
- Made in the USA
- Do Not Use for Overhead Lifting
- DO NOT EXCEED THE WORKING LOAD LIMIT



Cat. No.	UPC No.	Size/Trade Size	Packaging	Finish	Weight Each	Working Load Limit
T0226615	020418059995	5/16 in x 20 ft	25	Bright	20 lb	3900 lb
T0222925	020418174414	3/8 in x 20 ft	20	Bright	32 lb	5400 lb

Grade 43, Binder Chains, Packed in Pail or Vinyl Bag



- Binder Chains Manufactured Using Grade 43 Chain and Feature Forged Heat Treated Clevis Grab Hooks on Each End
- Standard Finish: Bright (Brt)
- Chains May Be Used in Accordance with Latest D.O.T. Regulations
- Used to Tie Down or "Bind" Loads for Transportation
- Packaged in Pails or Bags, Order Unit is "Each"
- Made in the USA
- Do Not Use for Overhead Lifting
- DO NOT EXCEED THE WORKING LOAD LIMIT



Cat. No.	UPC No.	Size/Trade Size	Packaging	Finish	Weight Each	Working Load Limit	Shelf Pack
T0222725	020418163067	3/8 in x 16 ft	1 per Bag	Bright	25 lb	5400 lb	
T0223698	020418264368	3/8 in x 20 ft	1 per Bag	Bright	32 lb	5400 lb	
T0223820	020418237829	3/8 in x 20 ft	3 per Pail	Bright	32 lb	5400 lb	3

Grade 70, Binder Chains



- Binder Chains Manufactured Using Grade 70 Chain and Feature Forged Heat Treated Clevis Grab Hooks on Each End
- Standard Finish: Chain Has Yellow Chromated Zinc Electroplate Finish, Hooks Are Bright Finish
- Chains May Be Used in Accordance with Latest D.O.T. Regulations
- Grade 70 Binder Chains Provide Higher Load-To-Weight Ratios
- Used to Tie Down or "Bind" Loads for Transportation
- Packaged in Drums, Order Unit is "Each"
- Made in the USA
- Do Not Use for Overhead Lifting
- DO NOT EXCEED THE WORKING LOAD LIMIT



Cat. No.	UPC No.	Size/Trade Size	Packaging	Finish	Weight Each	Working Load Limit
T0513572	020418174179	5/16 in x 16 ft	25	Yellow Chromate	17 lb	4700 lb

(continued)

Cat. No.	UPC No.	Size/Trade Size	Packaging	Finish	Weight Each	Working Load Limit
T0513574	020418174193	5/16 in x 20 ft (Short Link)	25	Yellow Chromate	24 lb	4700 lb
T0513576	020418212130	5/16 in x 20 ft (Long Link)	25	Yellow Chromate	22 lb	4700 lb
T0513575	020418174209	5/16 in x 25 ft	25	Yellow Chromate	30 lb	4700 lb
T0513660	020418064135	3/8 in x 16 ft	20	Yellow Chromate	27 lb	6600 lb
T0513665	020418064159	3/8 in x 20 ft	20	Yellow Chromate	32 lb	6600 lb
T0513667	020418064166	3/8 in x 25 ft	20	Yellow Chromate	39 lb	6600 lb
T0513765	020418178788	1/2 in x 20 ft	10	Yellow Chromate	54 lb	11300 lb

Grade 70, Binder Chains, Packed in Pail or Vinyl Bag



- Binder Chains Manufactured Using Grade 70 Chain and Feature Forged Heat Treated Clevis Grab Hooks on Each End
- Standard Finish: Chain Has Yellow Chromated Zinc Electroplate Finish, Hooks Are Bright Finish
- Chains May Be Used in Accordance with the Latest D.O.T. Regulations
- Packaged in Pails or Bags, Order Unit is "Each"
- Made in the USA
- Do Not Use for Overhead Lifting
- DO NOT EXCEED THE WORKING LOAD LIMIT



Cat. No.	UPC No.	Size/Trade Size	Packaging	Finish	Weight Each	Working Load Limit	Shelf Pack Qty.
T0513598	020418263248	5/16 in x 20 ft	1 per Bag	Yellow Chromate	22 lb	4700 lb	2
T0513668	020418289361	5/16 in x 20 ft	3 per Pail	Yellow Chromate	66 lb	4700 lb	3
T0513698	020418262937	3/8 in x 20 ft	1 per Bag	Yellow Chromate	32 lb	6600 lb	-
T0513678	020418237782	3/8 in x 20 ft	3 per Pail	Yellow Chromate	96 lb	6600 lb	3

Tow Chain



- Tow Chains Are Available in High Test or Transport Grade
- All Have Forged Clevis Hooks
- Tow Chains Are Subject to Shock Loading and Must Be Inspected Frequently
- They Must Be Taken Out of Service When Damaged
- Select the Right Chain for the Job According to the Working Load Limits
- Made in the USA
- Do Not Use for Overhead Lifting
- DO NOT EXCEED THE WORKING LOAD LIMIT

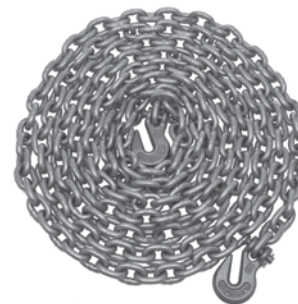

Cat. No.	UPC No.	Size/Trade Size	Chain Type	Finish	Weight Each	Working Load Limit	Packaging	Shelf Pack
T0231912	020418187681	5/16 in x 12 ft	High Test Chain w/Clevis Hooks	Hi-Viz Polycoat	14 lb	3900 lb	1 per Bag	2
T0231916	020418188756	5/16 in x 16 ft	High Test Chain w/Clevis Hooks	Hi-Viz Polycoat	18 lb	3900 lb	1 per Bag	2
T0513578	020418175794	5/16 in x 20 ft	Transport Chain w/Clevis Hooks	Yellow Chromate	22 lb	4700 lb	1 per Bag	2



Tow Cable

- Used for Towing, Logging
- Galvanized Cable with Zinc Plated Hooks
- Product Packaged in Clear, See-Through Plastic Clam Shells
- Eye Slip Hooks Swaged on Each End
- Do Not Use for Overhead Lifting
- DO NOT EXCEED THE WORKING LOAD LIMIT



Cat. No.	UPC No.	Size and Description	Working Load Limit	Weight Each	Shelf Pack
5977920	020418205453	5/16 in x 20 ft	1960 lb	5 lb	3

Porch Swing Chain Assembly with Hooks

- For Securing Porch Swings to Porch Ceilings
- Set Packaged One Pair Per Clam Shell, Includes Hooks for Installation
- The Rated Working Load Limit is 500Lb / 227Kg Per Pair



Cat. No.	UPC No.	Working Load Limit	Weight Per Package
T0702024N	020418331084	500 lb	3.300 lb

Hydraulic Chain Cutters

- Hydraulic Chain & Cable Cutter
- Model #44, Max Capacity: 3/8" G43 High Test Chain; 3/8" Steel Cable
- Model #88 HD, Max Capacity: 3/8" G70 Transport Chain; 3/8" Steel Cable; 1/2" G43 High Test Chain
- Both can be mounted to Campbell free standing or Lozier display
- MADE IN USA



Cat. No.	UPC No.	Capacity	Weight Each
7508495	020418135477	3/8 in	33 lb
7508595	020418178320	3/8 in - 1/2 in	38 lb



ACCESSORIES

Load Binders.....	41
“S” Hooks	41
Cold Shuts	42
Lap Links	42
Double Clevises	42
Hitch Pins.....	43
Clevises	44
Welded Rings.....	45
Seven Seas Welded Rings	46
Seven Seas Net Links	46
Welded Rings (Imported)	46
Dees.....	47
Swivels	47
Iron and Steel Snaps	48
Die Cast Zinc Snaps	50
Bronze Snaps.....	51
Stainless Steel Snaps	52
Links (Snap and Quick).....	52
Pulleys	55
Rope Clamps.....	56
Rope Cleats.....	57
Ferrules and Stops	57
Swaging Tool	57
Wire Rope Clips and Thimbles	58
Eye and Eye Swivels (Imported)	59
Shackles	59
Grab Hooks and Slip Hooks	60
Slip Hooks.....	61





Campbell® Accessories

Campbell began manufacturing harness hardware of malleable iron in 1873. Over the years, Campbell has added an extensive line of snaps made from malleable iron, steel, zinc, bronze, stainless steel, and aluminum. Campbell also offers a broad line of accessories to complement our chain and cable products, as well as products for use on synthetic webbing and rope.

Warnings, Cautions, Inspection and Proper Use of Chain

Certain precautions and standards of treatment should be observed when using Campbell accessories. Proper care will extend the useful life of the product.

SNAPS, PULLEYS, QUICK AND SPRING LINKS, RINGS AND SWIVELS

Campbell offers a full line of snap products made from a variety of materials to meet the needs of many applications. These products are designed and intended for light duty applications.

Typical and appropriate uses would include pet leashes, ancillary saddlery and tack, hanging plants, flagpoles, tarp covers, key rings, gate closures, luggage and shoulder bag straps. Snaps are not to be used for overhead lifting, to support human weight, for playground or athletic equipment, or as safety devices.

WARNINGS AND CAUTIONS:

- The use of accessories is subject to certain hazards that cannot be met by mechanical or manufacturing means, but only by the exercise of intelligence, care and common sense.
- Do not exceed the working load limit of the accessory.
- Chemically active environments may adversely affect accessories. Do not use in highly acidic or caustic environments. Campbell should be contacted if the accessory will be exposed to chemically active environments during use.
- High and low temperatures will affect accessories. Campbell should be contacted if temperatures below -20°F (-29°C) or above 200°F (93°C) will be experienced.
- Accessories, such as load binders, used in certain applications are subject to governmental regulations. Please follow all Federal, State and/or Local Department of Transportation, OSHA, or other applicable standards and regulations when using Campbell products.
- Never field weld or repair accessories.
- See specific information under “Inspection” and “Proper Use” sections.

INSPECTION

Regular inspections should be conducted on accessories to detect damage or deterioration from use. The accessory should be inspected for any of the below conditions. If present, the accessory should immediately be removed from service.

- Cracks.
- Excessive nicks or gouges.
- Excessive wear. The accessory should be removed from service if any dimension is worn more than 10% from the original dimension.
- Stretched, bent, twisted, or distorted parts.
- Excessive corrosion.
- Evidence of heat damage.
- Evidence of field welding.
- Any other condition which questions the integrity of the accessory.

PROPER USE

To protect the users and to prevent damage to the accessories, the following safe practices should be followed:

- Select the accessory suitable for the application and environment.
- Avoid shock loading.
- Avoid bending over sharp edges or corners.
- Avoid twisting.
- Follow the assembly instructions and cautions and warning on the product packaging.

Purchasers please note that all “Warnings and Cautions” apply to accessories as well as all chain, components and fittings. Purchasers are responsible for conveying the “Warnings and Cautions” including the “Inspection” and “Proper Use” section information to the end user. Campbell denies any liability for damage that results from use in excess of the working load limit or any abuse or misuse of the product. Any questions concerning the use of Campbell products may be directed to your Hillman Group Sales Representative or Customer Service.

NOTICE: The product specifications and dimensions are as accurate as possible at the time of printing. However, because we are continually improving the quality and design of our products, they can change without notice. The dimensions and weights are approximate nominal values, and some variation will occur. If specific dimensional requirements are necessary for the application, please contact your Hillman Group Sales Representative or Customer Service.



ADVERTENCIA

Para prevenir la posibilidad de una lesión personal sería:

- **NO EXCEDA** los límites de carga de las cadenas o componentes.
- **NO LA UTILICE** para cargar hacia arriba o para izar.
- **NO LA UTILICE** si la cadena o los componentes están visualmente distorsionados o gastados.



WARNING

To prevent the possibility of serious bodily injury:

- **DO NOT EXCEED** the working load limits for chain or components.
- **DO NOT USE** for overhead lifting or hoisting.
- **DO NOT USE** if the chain or components are visibly distorted or worn.

Load Binders

- To Tighten Chain, Typically for Cargo Securement
- Meets U.S. D.O.T. 393.100 -393.102 Requirements for Use with Chain
- Lever Type: Allows for Quicker Application of Load
- Ratchet Type: Allows for Easier Adjustment of Tension and Greater Range of Take-Up
- DO NOT EXCEED THE WORKING LOAD LIMIT
- Do Not Use for Overhead Lifting or Hoisting



Cat. No.	UPC No.	Style	For Chain Size & Grade	Finish	Take-Up	Quantity Per Pkg	Working Load Limit	Weight Each
6203205	020418178658	Lever Type, Imported	1/4" Gr.30 & Gr.43	Painted	2-3/4 in	4	2600 lb	3.40 lb
6203604	020418187162	Lever Type, Imported	5/16" Gr.70 to 3/8" Gr.43	Painted	4-1/2 in	4	5400 lb	8.05 lb
6207504	020418086472	Ratchet Type, Imported	5/16" Gr.70 to 3/8" Gr.43	Painted	8 in	Bulk	5400 lb	11.00 lb
6207506	020418228940	Ratchet Type, Imported	5/16" Gr.70 to 3/8" Gr.70	Yellow Chromate	8 in	2	6600 lb	11.00 lb
6207803	020418189425	Ratchet Type, Imported	3/8" Gr.70 to 1/2" Gr.43	Painted	8 in	Bulk	9200 lb	9.92 lb

S Hooks

- For Attaching Accessories to Chain
- After Engaging Chain, Close the "S" Hook to Prevent Disengagement
- Standard Material: Low Carbon Steel
- Order Unit is "Each"
- DO NOT EXCEED THE WORKING LOAD LIMIT
- Do Not Use for Overhead Lifting or Hoisting

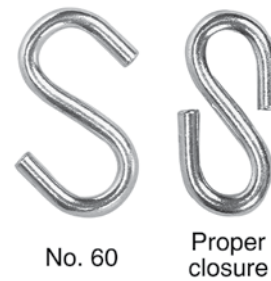

Trade Size	Cat. No.	UPC No.	Finish	Wire Size	Inside Length	Packaging	Working Load Limit	Weight Each	Shelf Pack
20	6102024	020418084836	Zinc Plated	0.08 in	27/32 in	50	16 lb	0.004 lb	50
40	6104024	020418084911	Zinc Plated	0.134 in	1 in	50	42 lb	0.01 lb	50
62	6106224	020418085086	Zinc Plated	0.175 in	1-3/8 in	50	60 lb	0.03 lb	50
70	6107014	020418085130	Bright	0.219 in	1-13/16 in	50	100 lb	0.05 lb	50
72	6107224	020418085215	Zinc Plated	0.225 in	1-1/2 in	50	100 lb	0.05 lb	50
80	6108024	020418085284	Zinc Plated	0.250 in	1-25/32 in	50	120 lb	0.07 lb	50
81	6108114	020418085338	Bright	0.250 in	2-1/2 in	50	150 lb	0.08 lb	50
100	6101024	020418084737	Zinc Plated	0.312 in	2-1/4 in	50	290 lb	0.12 lb	50
120	6101224	020418084782	Zinc Plated	0.375 in	2-3/8 in	50	410 lb	0.20 lb	50



Cold Shuts

- Connections for Chain and Attachments
- When Using Cold Shuts with Chain, Use One Size Larger Than Chain Size
- With A Hammer, Drive the Open End Through the Cold Shut Eye. Peen the Extended End to Prevent Opening
- Order Unit is "Each"
- Do Not Use for Overhead Lifting or Hoisting



Trade Size	Cat. No.	UPC No.	Finish	Inside Length	Inside Width	Working Load Limit	Packaging	Weight Each	Shelf Pack
3/16 in	T4900324	020418180118	Zinc Plated	15/16 in	11/32 in	400 lb	Bulk	0.02 lb	10
1/4 in	T4900424	020418180125	Zinc Plated	1-3/16 in	3/8 in	800 lb	Bulk	0.06 lb	10
5/16 in	T4900524	020418201448	Zinc Plated	1-3/8 in	7/16 in	1300 lb	Bulk	0.10 lb	10
3/8 in	T4900624	020418201455	Zinc Plated	1-1/2 in	5/8 in	1900 lb	Bulk	0.16 lb	10
1/2 in	T4900824	020418201462	Zinc Plated	1-7/8 in	3/4 in	3700 lb	Bulk	0.38 lb	10

Repair and Lap Links

- Connections for Chain and Attachments
- Chain is Inserted, Then Link is Hammered Closed
- Standard Material: Low Carbon Steel
- DO NOT EXCEED THE WORKING LOAD LIMIT



Trade Size	Cat. No.	UPC No.	Finish	Packaging	Working Load Limit	Weight Each	Shelf Pack
1/8 in x 3/4 in	T5950024	020418192807	Zinc Plated	Bulk	125 lb	0.01 lb	10
3/16 in x 1 in	T5800124	020418258510	Zinc Plated	Bulk	240 lb	0.03 lb	100
3/16 in x 1 in	T5950124	020418192623	Zinc Plated	Bulk	240 lb	0.03 lb	10
1/4 in x 1-1/4 in	5800324	020418081163	Zinc Plated	Bulk	400 lb	0.07 lb	50
1/4 in x 1-1/4 in	T5950324	020418192593	Zinc Plated	Bulk	400 lb	0.07 lb	10
5/16 in x 1-1/2 in	5800724	020418081330	Zinc Plated	Bulk	700 lb	0.10 lb	50
5/16 in x 1-1/2 in	T5950724	020418192609	Zinc Plated	Bulk	700 lb	0.10 lb	10
3/8 in x 1-5/8 in	5800924	020418081422	Zinc Plated	Bulk	1250 lb	0.20 lb	
3/8 in x 1-5/8 in	T5950924	020418192616	Zinc Plated	Bulk	1250 lb	0.20 lb	10
3/8 in x 2 in	5801024	020418081484	Zinc Plated	Bulk	1250 lb	0.20 lb	
1/2 in x 2-1/2 in	5801124	020418081521	Zinc Plated	Bulk	2125 lb	0.53 lb	

Double Clevises

- Forged Steel
- For Use with Proof Coil or High Test Chain
- Order Unit is "Each"
- DO NOT EXCEED THE WORKING LOAD LIMIT
- Do Not Use for Overhead Lifting or Hoisting

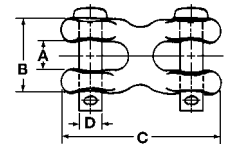

Trade Size	Cat. No.	UPC No.	Finish	A Dim.	B Dim.	C Dim.	D Dim.	Working Load Limit	Weight Each	Shelf Pack
1/4 in x 5/16 in	T5423300	020418191534	Zinc Plated	7/16 in	1-1/16 in	2-1/2 in	3/8 in	3900 lb	0.36 lb	10
3/8 in	T5423301	020418191541	Zinc Plated	1/2 in	1-5/16 in	2-27/32 in	7/16 in	5400 lb	0.55 lb	10
7/16 in x 1/2 in	T5423302	020418204869	Zinc Plated	5/8 in	1-5/8 in	3-5/8 in	9/16 in	9200 lb	1.04 lb	5

Yellow Chromate Hitch Pins

- Forged Steel
- Standard Finish: Zinc Plate with Yellow Chromate
- Includes Hair Pin Clip
- UPC Tagged
- Order Unit is “Each”



Cat. No.	UPC No.	Pin Diameter	Usable Length	Weight Each	Shelf Pack	Case Pack
T3899733	020418257421	3/8 in	3 in	0.20 lb	5	40
T3899724	020418257414	1/2 in	4-1/4 in	0.36 lb	5	40
T3899720	020418210952	5/8 in	4 in	0.60 lb	4	40
T3899752	020418210990	5/8 in	6 in	0.80 lb	4	40
T3899728	020418210969	3/4 in	4-1/4 in	1.00 lb	4	40
T3899760	020418211003	3/4 in	6-1/4 in	1.10 lb	4	40
T3899736	020418210976	7/8 in	4-1/4 in	1.20 lb	2	20
T3899768	020418211010	7/8 in	6-1/2 in	1.50 lb	2	20
T3899744	020418210983	1 in	4-1/2 in	1.60 lb	2	20
T3899776	020418211027	1 in	6-3/4 in	2.10 lb	2	20

Red Handle Hitch Pins

- Forged, Heated Treated, Grade 5 Strength
- Pin Has Black Powder Coating with A Red Vinyl Coated Head and Handle with Yellow Zinc Plated Hair Pin Clip
- UPC Tagged
- Order Unit is “Each”



Cat. No.	UPC No.	Pin Diameter	Usable Length	Weight Each	Shelf Pack	Case Pack
T3898910	020418257490	1/2 in	3-5/8 in	0.49 lb	5	20
T3898954	020418257483	5/8 in	4 in	0.67 lb	5	20
T3898956	020418257476	5/8 in	5-1/2 in	0.79 lb	5	20
T3898934	020418257452	3/4 in	4-1/2 in	1.04 lb	2	10
T3898936	020418257469	3/4 in	6-1/2 in	1.27 lb	2	10
T3898976	020418257445	7/8 in	6-1/2 in	1.74 lb		5
T3898917	020418257438	1 in	7-1/2 in	2.38 lb		5



Hitch Pin Clips

- Replacement Clips for Hitch Pins
- Yellow Zinc Plated for Corrosion Resistance
- Order Unit is "Bag"



Trade Size	Cat. No.	UPC No.	Fits Pin Diameter	Wire Size	I.D. Of Eye	Packaging	Overall Length	Weight Each	Shelf Pack
1/16 in	B3899816	020418257513	3/8 in	0.077 in	7/16 in	10	1.75 in	0.06 lb	10
3/32 in	B3899832	020418257520	3/8 in	0.099 in	1/2 in	10	2.0 in	0.09 lb	10
1/8 in	B3899818	020418257537	1/2 in	0.11 in	3/4 in	10	3.0 in	0.15 lb	10
5/32 in	B3899852	020418257544	1/2 in & 5/8 in	0.15 in	3/4 in	7	3.125 in	0.23 lb	10
3/16 in	B3899836	020418257551	3/4 in & 7/8 in	0.188 in	1 in	5	4.0 in	0.34 lb	10
1/4 in	B3899814	020418257568	1 in	0.23 in	1-1/4 in	2	5.0 in	0.26 lb	10

ACCESSORIES

Straight and Twisted Clevises

- Forged Steel
- UPC Tagged
- DO NOT EXCEED THE WORKING LOAD LIMIT
- Do Not Use for Overhead Lifting or Hoisting

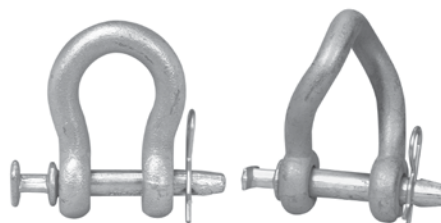

Cat. No.	UPC No.	Body Type	Body Diameter	Finish	Pin Diameter	Working Load Limit	Weight Each	Shelf Pack
T3899910	020418211775	Straight, Short	7/8 in	Electro-Galvanized	3/4 in	16000 lb	2.97 lb	5
T3899913	020418211768	Twisted, Short	7/8 in	Electro-Galvanized	3/4 in	16000 lb	2.97 lb	3
T3899916	020418211799	Straight, Long	7/8 in	Electro-Galvanized	3/4 in	16000 lb	3.30 lb	2
T3899919	020418211782	Twisted, Long	7/8 in	Electro-Galvanized	3/4 in	16000 lb	3.30 lb	2

Utility Clevises

- Forged Steel
- Blue Powder Coat Finish
- Design Factor: 5 to 1
- Working Load Limit Marked on Clevis Body
- UPC Tagged
- DO NOT EXCEED THE WORKING LOAD LIMIT



Trade Size	Cat. No.	UPC No.	Style	Finish	WLL (Short Tons)	Packaging	Weight Each	Shelf Pack	Case Pack
1/4 in	T9420405	020418257292	Round Pin	Powder Coating	1/2 t	Bulk	0.10 lb	10	100
5/16 in	T9420505	020418257285	Round Pin	Powder Coating	3/4 t	Bulk	0.17 lb	10	100
3/8 in	T9420605	020418257278	Round Pin	Powder Coating	1 t	Bulk	0.27 lb	10	100
7/16 in	T9420705	020418257254	Round Pin	Powder Coating	1-1/2 t	Bulk	0.38 lb	5	50
1/2 in	T9420805	020418257247	Round Pin	Powder Coating	2 t	Bulk	0.60 lb	5	50
5/8 in	T9421005	020418257261	Round Pin	Powder Coating	3-1/4 t	Bulk	1.17 lb		25

Farm Clevises

- Forged Steel
- Blue Powder Coat Finish
- Design Factor: 5 to 1
- Working Load Limit Marked on Clevis Body
- UPC Tagged
- DO NOT EXCEED THE WORKING LOAD LIMIT



Trade Size	Cat. No.	UPC No.	Style	Finish	WLL (Short Tons)	Packaging	Weight Each	Shelf Pack	Case Pack
1/4 in	T9640405	020418257407	Screw Pin	Powder Coating	1/2 T	Bulk	0.10 lb	10	100
5/16 in	T9640505	020418257391	Screw Pin	Powder Coating	3/4 T	Bulk	0.18 lb	10	100
3/8 in	T9640605	020418257384	Screw Pin	Powder Coating	1 T	Bulk	0.30 lb	10	100
7/16 in	T9640705	020418257377	Screw Pin	Powder Coating	1-1/2 T	Bulk	0.40 lb	5	50
1/2 in	T9640805	020418257360	Screw Pin	Powder Coating	2 T	Bulk	0.63 lb	5	50
5/8 in	T9641005	020418257353	Screw Pin	Powder Coating	3-1/4 T	Bulk	1.34 lb		25
3/4 in	T9641205	020418257346	Screw Pin	Powder Coating	4-3/4 T	Bulk	2.22 lb		15
7/8 in	T9641405	020418257339	Screw Pin	Powder Coating	6-1/2 T	Bulk	3.34 lb		10
1 in	T9641605	020418257322	Screw Pin	Powder Coating	8-1/2 T	Bulk	4.93 lb		5
1-1/8 in	T9641805	020418257315	Screw Pin	Powder Coating	9-1/2 T	Bulk	6.79 lb		5
1-1/4 in	T9642005	020418257308	Screw Pin	Powder Coating	12 T	Bulk	9.93 lb		5

Welded Rings

- Made of Low Carbon Steel
- General Attachment for Chain or Rope
- DO NOT EXCEED THE WORKING LOAD LIMIT
- Do Not Use for Overhead Lifting or Hoisting



Trade Size	Cat. No.	UPC No.	Inside Diameter	Finish	Packed Per Box	Packaging	Working Load Limit	Weight Each	Shelf Pack
3/16 in	6050314	020418083518	1-1/4 in	Bright	25	Boxed	200 lb	0.03 lb	25
1/4 in	6050414	020418083556	1-1/2 in	Bright	25	Boxed	450 lb	0.08 lb	25
1/4 in	6050424	020418083570	1-1/2 in	Zinc Plated	25	Boxed	450 lb	0.08 lb	25
1/4 in	6052414	020418083914	2 in	Bright	25	Boxed	350 lb	0.10 lb	25
5/16 in	6050514	020418083600	2 in	Bright	25	Boxed	600 lb	0.16 lb	25
3/8 in	6050614	020418083655	2 in	Bright	25	Boxed	900 lb	0.23 lb	25
3/8 in	6050624	020418083679	2 in	Zinc Plated	25	Boxed	900 lb	0.20 lb	25
3/8 in	6053614	020418084164	3 in	Bright	25	Boxed	700 lb	0.33 lb	
1/2 in	6052814	020418084027	2-1/2 in	Bright	10	Boxed	1400 lb	0.60 lb	10
5/8 in	6051014	020418083747	4 in	Bright	10	Boxed	1700 lb	1.45 lb	



Seven Seas Welded Rings

- Made of Low Carbon Steel
- For Use in the Construction of Scallop Dredge Nets
- Order Unit is "Pound"
- Do Not Use for Overhead Lifting or Hoisting



Trade Size	Cat. No.	UPC No.	Inside Diameter	Pounds Per Pail	Pieces Per Package	Working Load Limit	Shelf Pack
1/4 in	6052418*	020418083938	2 in	50 lb	500	350 lb	50
7/16 in	6055988*	020418193521	4 in	50 lb	80	-	-

* Pieces per package is approximate; Case Hardened

ACCESSORIES

Seven Seas Net Links

- Shaped to Facilitate Uniform Closing
- Links Are Heat Treated
- Provide the Hardness and Strength Required for Deep Sea Scallop Dredging
- Order Unit is "Pound"



Trade Size	Cat. No.	UPC No.	Wire Size	Inside Length	Pounds Per Pail	Pieces Per Package	Shelf Pack
719	6010898*	020418083440	3/8 in	1-1/8 in	50 lb	375	50
719	6011898*	020418189418	3/8 in	1 in	50 lb	500	50

* Pieces per package is approximate

Welded Rings (Imported)

- For General Chain & Rope Attachment
- Do Not Use for Overhead Lifting or Hoisting



Figure No.	Trade Size	Cat. No.	UPC No.	Style	Finish	A Dim.	B Dim.	Packaging	Working Load Limit	Weight Each	Shelf Pack	Case Pack
7	1 in	T7665012	020418201301	Steel Ring	Nickel Plated	1.00 in	0.18 in	Bulk	200 lb	0.03 lb	10	100
7B	1-1/8 in	T7662114	020418201288	Solid Bronze Ring	Polished	1.125 in	0.21 in	Bulk	150 lb	0.04 lb	10	100
4	1-1/4 in	T7660841	020418192845	Steel Ring	Zinc Plated	1.25 in	0.22 in	Bulk	200 lb	0.05 lb	10	100
7	1-1/4 in	T7665032	020418201318	Steel Ring	Nickel Plated	1.25 in	0.18 in	Bulk	200 lb	0.03 lb	10	100
3	1-1/2 in	T7665042	020418201325	Steel Ring	Nickel Plated	1.50 in	0.24 in	Bulk	200 lb	0.05 lb	10	100
3	2 in	T7661152	020418192036	Steel Ring	Nickel Plated	2.00 in	0.24 in	Bulk	200 lb	0.09 lb	10	100
7B	2 in	T7662154	020418192050	Solid Bronze Ring	Polished	2.00 in	0.25 in	Bulk	150 lb	0.12 lb	10	100
-	2 in	T7663550	020418211898	Hitch Ring w/ 3-1/2" Screw Eye	Zinc Plated	2.00 in	0.26 in	Bulk	90 lb	0.21 lb	5	50
2	2 in	T7665001	020418201295	Steel Ring	Nickel Plated	2.00 in	0.26 in	Bulk	200 lb	0.10 lb	10	100
2	2-1/2 in	T7661361	020418192043	Steel Ring	Zinc Plated	2.50 in	0.26 in	Bulk	200 lb	0.14 lb	10	100

Dees

- Used to Attach a Strap to an Accessory
- Do Not Use for Overhead Lifting or Hoisting

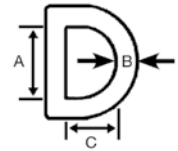

Figure No.	Trade Size	Cat. No.	UPC No.	Finish	Working Load Limit	A Dim.	B Dim.	C Dim.	Weight Each	Shelf Pack	Case Pack
3250	1 in	T7662322	020418204821	Nickel Plated	200 lb	1.00 in	0.21 in	0.81 in	0.03 lb	10	100
3250	1-1/4 in	T7662342	020418192067	Zinc Plated	200 lb	1.125 in	0.24 in	1.125 in	0.07 lb	10	100
3250	1-1/2 in	T7662351	020418192074	Zinc Plated	200 lb	1.50 in	0.24 in	1.50 in	0.08 lb	10	100
3250	2 in	T7662372	020418204845	Nickel Plated	200 lb	2.00 in	0.26 in	2.00 in	0.11 lb	10	100

Open Eye Swivels

- Used to Couple Weldless Chain, Prevents Tangling
- Eyes Easily Closed with Hammer



Proper closure

Size No.	Cat. No.	UPC No.	For Chain Size	Finish	Working Load Limit	Packaging	Weight Each	Shelf Pack
1020	T5901024	020418192852	1/0 & 2/0 Inco (Double Loop)	Zinc Plated	100 lb	Bulk	0.05 lb	10

Double End Swivels

- Used for Connecting Chain or Rope
- Swivel Feature Allows for Less Kinking or Tangling of Chain
- Zinc Die Cast Construction
- DO NOT EXCEED THE WORKING LOAD LIMIT
- Do Not Use for Overhead Lifting or Hoisting

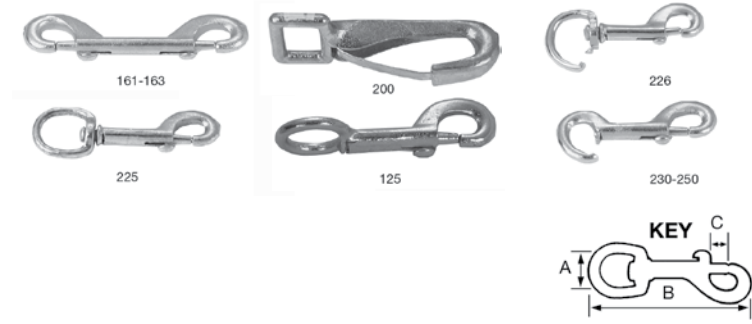

Figure No.	Trade Size	Cat. No.	UPC No.	Finish	Packaging	Working Load Limit	Weight Each	Shelf Pack	Case Pack
2225Z	5/8 in	T7640302	020418191930	Nickel Plated	Bulk	90 lb	0.08 lb	10	100
2225Z	3/4 in	T7616202	020418191831	Nickel Plated	Bulk	100 lb	0.08 lb	10	100
2225Z	1 in	T7640322	020418191947	Nickel Plated	Bulk	100 lb	0.18 lb	10	100



Malleable Iron and Steel Snaps

- Typical uses include Tarp Covers, Key Rings, Gate Closures, Flagpoles, and Other Home, Farm, Recreational and Marine Applications
- Zinc Plated Finish
- Also Ideal for Pet Leashes and Tie-Outs
- DO NOT EXCEED THE WORKING LOAD LIMIT
- Do Not Use for Overhead Lifting or Hoisting



ACCESSORIES

Figure No.	Trade Size	Cat. No.	UPC No.	Style	A Dim.	B Dim.	C Dim.	Working Load Limit	Packaging	Weight Each	Shelf Pack	Case Pack
230	3/8 in	T7606001	020418201035	Rigid, Open Eye Bolt Snap	3/8 in	3-3/8 in	11/32 in	40 lb	Bulk	0.10 lb	10	100
231	3/8 in	T7606011	020418191725	Rigid, Open Eye Bolt Snap	3/8 in	3-1/2 in	13/32 in	60 lb	Bulk	0.12 lb	10	100
225	1/2 in	T7601201	020418191565	Swiveling, Round Eye Bolt Snap	1/2 in	4 in	3/8 in	110 lb	Bulk	0.13 lb	10	100
245	1/2 in	T7601451	020418191589	Rigid, Open Eye Bolt Snap	1/2 in	5-1/4 in	1/2 in	200 lb	Bulk	0.42 lb	10	50
232	1/2 in	T7606021	020418191732	Rigid, Open Eye Bolt Snap	1/2 in	4 in	7/16 in	60 lb	Bulk	0.15 lb	10	100
240	1/2 in	T7606031	020418191749	Rigid, Open Eye Bolt Snap	1/2 in	4-1/4 in	15/32 in	100 lb	Bulk	0.23 lb	10	100
125	5/8 in	T7600311	020418191558	Rigid, Round Eye Bolt Snap	5/8 in	5 in	11/32 in	70 lb	Bulk	0.14 lb	10	100
250	5/8 in	T7601461	020418191596	Rigid, Open Eye Bolt Snap	5/8 in	7 in	9/16 in	240 lb	Bulk	0.64 lb	10	100
225	5/8 in	T7605801	020418191695	Swiveling, Round Eye Bolt Snap	5/8 in	4 in	3/8 in	110 lb	Bulk	0.14 lb	10	100
200	3/4 in	T7600511-02	020418370281	Rigid, Strap Eye Spring Snap	3/4 in	3 in	3/8 in	80 lb	Bulk	0.10 lb	10	100
225	3/4 in	T7605811	020418191701	Swiveling, Round Eye Bolt Snap	3/4 in	4-1/4 in	3/8 in	100 lb	Bulk	0.14 lb	10	100
200	1 in	T7600531-02	020418370298	Rigid, Strap Eye Spring Snap	1 in	3-1/4 in	7/16 in	90 lb	-	0.10 lb	10	100
225	1 in	T7605821	020418191718	Swiveling, Round Eye Bolt Snap	1 in	4-5/8 in	15/32 in	100 lb	Bulk	0.20 lb	10	100
200	1-1/2 in	T7600561-02	020418370304	Rigid, Strap Eye Spring Snap	1-1/2 in	3-13/16 in	1/2 in	80 lb	Bulk	0.11 lb	10	100
161	3-1/2 in	T7605501	020418201028	Double Ended Bolt Snap	-	3-1/2 in	9/32 in	70 lb	Bulk	0.10 lb	10	100
162	4-1/8 in	T7605511	020418191671	Double Ended Bolt Snap	-	4-1/8 in	13/32 in	70 lb	Bulk	0.14 lb	10	100
163	4-3/4 in	T7605521	020418191688	Double Ended Bolt Snap	-	4-3/4 in	3/8 in	110 lb	Bulk	0.18 lb	10	100

Malleable Iron and Steel Snaps

- Typical uses include Tarp Covers, Key Rings, Gate Closures, Flagpoles, and Other Home, Farm, Recreational and Marine Applications
- Also Ideal for Pet Leashes and Tie-Outs
- DO NOT EXCEED THE WORKING LOAD LIMIT
- Do Not Use for Overhead Lifting or Hoisting

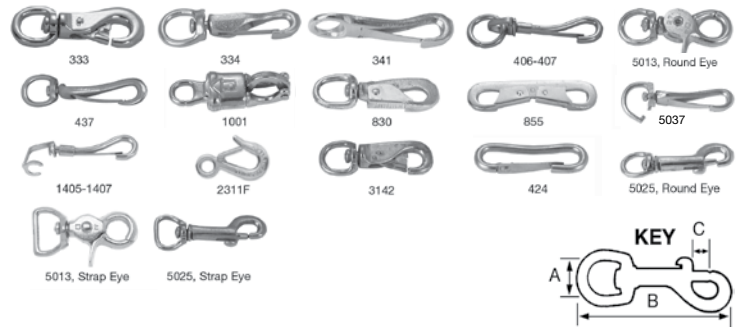

Figure No.	Trade Size	Cat. No.	UPC No.	Style	A Dim.	B Dim.	C Dim.	Working Load Limit	Packaging	Weight Each	Shelf Pack	Case Pack
334	3/8 in	T7601912	020418191619	Swiveling, Round Eye Spring Snap	3/8 in	2 in	5/32 in	20 lb	Bulk	0.02 lb	10	100
341	3/8 in	T7602301	020418192630	Rigid, Round Eye Spring Snap	3/8 in	2 in	5/32 in	30 lb	Bulk	0.03 lb	10	100
437	3/8 in	T7606502	020418191756	Swiveling, Round Eye Spring Snap	3/8 in	2-1/2 in	7/32 in	30 lb	Bulk	0.04 lb	10	100
5025	3/8 in	T7607602	020418191787	Swiveling, Round Eye Bolt Snap	3/8 in	2-7/8 in	5/16 in	60 lb	Bulk	0.07 lb	10	100
5037	3/8 in	T7607702	020418201080	Swiveling, Open Eye Spring Snap	3/8 in	2-1/2 in	7/32 in	30 lb	Bulk	0.04 lb	10	100
1001	1/2 in	T7604002	020418191657	Rigid, Round Eye Panic Snap	1/2 in	4 in	-	140 lb	Bulk	0.31 lb	10	100
5013	5/8 in	T7604622	020418191664	Swiveling, Strap Eye Trigger Snap	5/8 in	2-1/2 in	3/8 in	70 lb	Bulk	0.09 lb	10	100
407	3/4 in	T7606301	020418201059	Swiveling, Round Eye Spring Snap	3/4 in	4-1/8 in	9/32 in	80 lb	Bulk	0.10 lb	10	100
2311F	3/4 in	T7620934	020418238130	Latched, Snap Hook	3/4 in	4 in	7/8 in	750 lb	Bulk	0.33 lb	10	100
333	7/8 in	T7601801	020418191602	Swiveling, Round Eye Animal Snap	7/8 in	5 in	9/16 in	440 lb	Bulk	0.66 lb	10	50
3142	7/8 in	T7607401	020418191763	Swiveling, Round Eye Animal Snap	7/8 in	4-7/8 in	7/8 in	300 lb	Bulk	0.44 lb	10	100
830	3/4 in	T7606801	020418201066	Swiveling, Round Eye Cap Snap	3/4 in	3-1/2 in	11/32 in	100 lb	Bulk	0.13 lb	10	100
830	1 in	T7603441	020418191640	Swiveling, Round Eye Cap Snap	1 in	4-1/2 in	7/16 in	190 lb	Bulk	0.22 lb	10	100
424	2-1/2 in	T7602611	020418191626	Breaching Snap	-	2-1/2 in	9/32 in	80 lb	Bulk	0.06 lb	10	100
1407	3-3/4 in	T7607301	020418201073	Swiveling, Open Eye Spring Snap	-	3-3/4 in	5/16 in	60 lb	Bulk	0.06 lb	10	100
855	5-1/4 in	T7603911	020418193712	Double Ended Cap Snap	-	5-1/4 in	7/16 in	250 lb	Bulk	0.26 lb	10	100

ACCESSORIES



Die Cast Zinc Snaps

- Typical uses include Tarp Covers, Key Rings, Gate Closures, Flagpoles, and Other Home, Farm, Recreational and Marine Applications
- Also Ideal for Pet Leashes and Tie-Outs
- Nickel Plated Finish
- Zinc Die Cast Construction
- DO NOT EXCEED THE WORKING LOAD LIMIT
- Do Not Use for Overhead Lifting or Hoisting



Figure No.	Trade Size	Cat. No.	UPC No.	Style	Finish	A Dim.	B Dim.	C Dim.	Working Load Limit	Weight Each	Shelf Pack	Case Pack
162Z		T7615302	020418201134	Double Ended Bolt Snap	Nickel Plated		4 in	3/8 in	60 lb	0.11 lb	10	100
163Z		T7615312	020418191800	Double Ended Bolt Snap	Nickel Plated		4-5/8 in	7/16 in	70 lb	0.15 lb	10	100
334Z	1/4 in	T7615602	020418191824	Swiveling, Round Eye Spring Snap	Nickel Plated	1/4 in	2 in	7/32 in	20 lb	0.02 lb	10	100
437Z	3/8 in	T7615902	020418201189	Swiveling, Round Eye Spring Snap	Nickel Plated	3/8 in	2-9/16 in	9/32 in	30 lb	0.02 lb	10	100
5013Z	3/8 in	T7616402	020418193538	Swiveling, Round Eye Trigger Snap	Nickel Plated	3/8 in	2-7/16 in	3/8 in	30 lb	0.09 lb	10	100
5025Z	3/8 in	T7616702	020418201196	Swiveling, Round Eye Bolt Snap	Nickel Plated	3/8 in	2-11/16 in	5/16 in	50 lb	0.06 lb	10	100
225Z	1/2 in	T7615012	020418201110	Swiveling, Round Eye Bolt Snap	Nickel Plated	1/2 in	3-1/2 in	3/8 in	90 lb	0.09 lb	10	100
5013Z	1/2 in	T7616412	020418179723	Swiveling, Round Eye Trigger Snap	Nickel Plated	1/2 in	2-11/16 in	3/8 in	40 lb	0.08 lb	10	100
125Z	5/8 in	T7615202	020418201127	Rigid, Round Eye Bolt Snap	Nickel Plated	5/8 in	3-3/8 in	3/8 in	90 lb	0.08 lb	10	100
225Z	5/8 in	T7615402	020418201141	Swiveling, Round Eye Bolt Snap	Nickel Plated	5/8 in	3-1/2 in	3/8 in	80 lb	0.10 lb	10	100
251Z	5/8 in	T7615502	020418191817	Swiveling, Round Eye Quick Snap	Nickel Plated	5/8 in	3-3/8 in	5/8 in	80 lb	0.13 lb	10	100
435Z	5/8 in	T7615802	020418201172	Swiveling, Strap Eye Spring Snap	Nickel Plated	5/8 in	2-5/8 in	9/32 in	30 lb	0.04 lb	10	100
225Z	3/4 in	T7615412	020418201158	Swiveling, Round Eye Bolt Snap	Nickel Plated	3/4 in	3-11/16 in	3/8 in	70 lb	0.11 lb	10	100
5015Z	3/4 in	T7616602	020418191855	Swiveling, Round Eye Trigger Snap	Nickel Plated	3/4 in	4 in	9/16 in	90 lb	0.15 lb	10	100
3142Z	7/8 in	T7616302	020418191848	Swiveling, Round Eye Animal Snap	Nickel Plated	7/8 in	4-13/16 in	7/8 in	150 lb	0.35 lb	10	100
017Z	1 in	T7610102	020418201097	Swiveling, Strap Eye Bolt Snap	Nickel Plated	1 in	3-3/16 in	3/8 in	80 lb	0.10 lb	10	100
251Z	1 in	T7610832	020418201103	Swiveling, Round Eye Quick Snap	Nickel Plated	1 in	3-13/16 in	5/8 in	70 lb	0.14 lb	10	100
25Z	1 in	T7615102	020418191794	Rigid, Strap Eye Bolt Snap	Nickel Plated	1 in	3-1/16 in	3/8 in	40 lb	0.09 lb	10	100
225Z	1 in	T7615422	020418201165	Swiveling, Round Eye Bolt Snap	Nickel Plated	1 in	4-1/4 in	1/2 in	90 lb	0.17 lb	10	100

Solid Bronze Snaps

- Typical uses include Tarp Covers, Key Rings, Gate Closures, Flagpoles, and Other Home, Farm, Recreational and Marine Applications
- Also Ideal for Pet Leashes and Tie-Outs
- Polished Finish
- DO NOT EXCEED THE WORKING LOAD LIMIT
- Do Not Use for Overhead Lifting or Hoisting



Figure No.	Trade Size	Cat. No.	UPC No.	Style	Finish	A Dim.	B Dim.	C Dim.	WLL	Packaging	Weight Each	Shelf Pack	Case Pack
161B		T7625004	020418201226	Double Ended Bolt Snap	Polished		3-13/32 in	5/16 in	60 lb	Bulk	0.10 lb	10	100
163B		T7625014	020418201233	Double Ended Bolt Snap	Polished		4-1/2 in	13/32 in	100 lb	Bulk	0.18 lb	10	100
225B	1-1/4 in	T7620334	020418191862	Swiveling, Round Eye Bolt Snap	Polished	1-1/4 in	4-3/4 in	19/32 in	120 lb	Bulk	0.30 lb	10	100
225B	5/8 in	T7625104	020418191886	Swiveling, Round Eye Bolt Snap	Polished	5/8 in	3-1/8 in	3/8 in	70 lb	Bulk	0.12 lb	10	100
225B	3/4 in	T7625114	02041819785	Swiveling, Round Eye Bolt Snap	Polished	3/4 in	3-1/8 in	3/8 in	70 lb	Bulk	0.12 lb	10	100
225B	1 in	T7625124	020418191893	Swiveling, Round Eye Bolt Snap	Polished	1 in	3-17/32 in	3/8 in	90 lb	Bulk	0.10 lb	10	100
231B	3/8 in	T7625204	020418179792	Rigid, Open Eye Bolt Snap	Polished	3/8 in	3-13/32 in	3/8 in	70 lb	Bulk	0.15 lb	10	100
249B	3/4 in	T7620534	020418201202	Rigid, Round Eye Quick Snap	Polished	3/4 in	3-15/64 in	9/16 in	140 lb	Bulk	0.28 lb	10	100
249B	3/8 in	T7625304	020418201240	Rigid, Round Eye Quick Snap	Polished	3/8 in	2-5/32 in	9/32 in	60 lb	Bulk	0.07 lb	10	100
249B	5/8 in	T7625314	020418201257	Rigid, Round Eye Quick Snap	Polished	5/8 in	2-7/8 in	3/4 in	70 lb	Bulk	0.10 lb	10	100
249B	11/16 in	T7625324	020418193743	Rigid, Round Eye Quick Snap	Polished	11/16 in	3-29/32 in	19/32 in	100 lb	Bulk	0.18 lb	10	100
251B	11/16 in	T7620614	020418201219	Swiveling, Round Eye Quick Snap	Polished	11/16 in	3-11/16 in	7/16 in	60 lb	Bulk	0.02 lb	10	100
251B	5/8 in	T7625404	020418201264	Swiveling, Round Eye Quick Snap	Polished	5/8 in	3-1/8 in	5/16 in	60 lb	Bulk	0.10 lb	10	100
251B	3/4 in	T7625434	020418201271	Swiveling, Round Eye Quick Snap	Polished	3/4 in	4-1/2 in	9/16 in	140 lb	Bulk	0.30 lb	10	100
2311B	3/4 in	T7620804	020418191879	Latched, Snap Hook	Polished	3/4 in	4-1/16 in	5/8 in	140 lb	Bulk	0.29 lb	10	100
5013B	1/2 in	T7625504	020418191909	Swiveling, Round Eye Trigger Snap	Polished	1/2 in	2-1/2 in	1/2 in	40 lb	Bulk	0.09 lb	10	100
5025B	3/8 in	T7625604	020418191916	Swiveling, Round Eye Bolt Snap	Polished	3/8 in	2-15/16 in	1/4 in	80 lb	Bulk	0.08 lb	10	100
5025B	1/2 in	T7625614	020418191923	Swiveling, Round Eye Bolt Snap	Polished	5/8 in	3-1/16 in	1/4 in	40 lb	Bulk	0.05 lb	10	100



Stainless Steel Snaps

- Typical uses include Tarp Covers, Key Rings, Gate Closures, Flagpoles, and Other Home, Farm, Recreational and Marine Applications
- Also Ideal for Pet Leashes and Tie-Outs
- Polished Finish
- DO NOT EXCEED THE WORKING LOAD LIMIT
- Do Not Use for Overhead Lifting or Hoisting

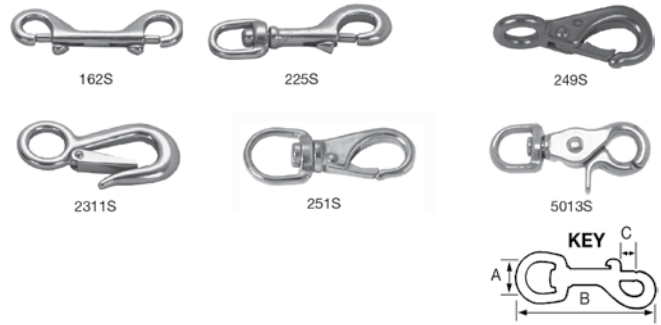

Figure No.	Trade Size	Cat. No.	UPC No.	Style	Finish	A Dim.	B Dim.	C Dim.	WLL	Packaging	Weight Each	Shelf Pack	Case Pack
162S		T7631204	020418201332	Double Ended Bolt Snap	Polished		4 in	3/8 in	130 lb	Bulk	0.14 lb	10	100
225S	1/2 in	T7631304	020418179907	Swiveling, Round Eye Bolt Snap	Polished	1/2 in	3-5/16 in	3/8 in	170 lb	Bulk	0.10 lb	10	100
225S	3/4 in	T7631324	020418201349	Swiveling, Round Eye Bolt Snap	Polished	3/4 in	3-3/32 in	3/8 in	180 lb	Bulk	0.11 lb	10	100
249S	3/8 in	T7631404	020418204647	Rigid, Round Eye Quick Snap	Polished	3/8 in	2-5/32 in	9/32 in	90 lb	Bulk	0.04 lb	10	100
249S	5/8 in	T7631414	020418201356	Rigid, Round Eye Quick Snap	Polished	5/8 in	2-7/8 in	3/8 in	160 lb	Bulk	0.11 lb	10	100
249S	3/4 in	T7631434	020418201363	Rigid, Round Eye Quick Snap	Polished	3/4 in	3-29/32 in	9/16 in	190 lb	Bulk	0.24 lb	10	100
251S	11/16 in	T7631524	020418193514	Swiveling, Round Eye Quick Snap	Polished	11/16 in	3-11/16 in	7/16 in	220 lb	Bulk	0.20 lb	10	100
251S	3/4 in	T7631534	020418201370	Swiveling, Round Eye Quick Snap	Polished	3/4 in	4-1/2 in	9/16 in	200 lb	Bulk	0.31 lb	10	100
2311S	3/4 in	T7631604	020418201387	Latched, Snap Hook	Polished	3/4 in	4-1/16 in	5/8 in	400 lb	Bulk	0.23 lb	10	100
2311S	1-1/8 in	T7631614	020418201394	Latched, Snap Hook	Polished	1-1/8 in	4-21/32 in	23/32 in	400 lb	Bulk	0.34 lb	10	50
5013S	1/2 in	T7631704	020418201400	Swiveling, Round Eye Trigger Snap	Polished	1/2 in	2-15/32 in	7/16 in	80 lb	Bulk	0.10 lb	10	100
5025S	1/2 in	T7631804	020418179983	Swiveling, Round Eye Bolt Snap	Polished	1/2 in	2-15/16 in	1/4 in	50 lb	Bulk	0.08 lb	10	100

Aluminum Spring Snap Link

- Aluminum Spring Snap
- Shipped in Assorted Colors
- DO NOT EXCEED THE WORKING LOAD LIMIT
- Do Not Use for Overhead Lifting or Hoisting
- Do Not Use to Support Human Weight, for Playground or Athletic Equipment, or as a Safety Device



Trade Size	Cat. No.	UPC No.	Opening	Inside Length	Inside Width	Overall Length	Packaging	Working Load Limit	Weight Each	Shelf Pack	Case Pack
5/16 in	T7645000	020418206092	0.50 in	2.50 in	1.125 in	3.125 in	Bulk	75 lb	0.05 lb	10	100

Spring Snap Links

- Ideal for Hanging Keys and Other Utility Items From Belt
- Fast and Easy to Connect and Disconnect
- Zinc Plated Finish
- DO NOT EXCEED THE WORKING LOAD LIMIT
- Do Not Use for Overhead Lifting or Hoisting
- Do Not Use to Support Human Weight, for Playground or Athletic Equipment, or as a Safety Device

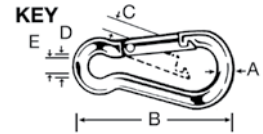

Trade Size	Cat. No.	UPC No.	(A) Material Diameter	(B) Length	(C) Opening	(D) Eye Diameter	(E) Inside Width	Packaging	Working Load Limit	Weight Each	Shelf Pack	Case Pack
1/4 in	T7645006	020418201585	0.19 in	1.93 in	0.26 in	0.32 in	0.26 in	Bulk	80 lb	0.03 lb	10	100
5/16 in	T7645016	020418201592	0.23 in	2.40 in	0.29 in	0.37 in	0.31 in	Bulk	130 lb	0.05 lb	10	100
3/8 in	T7645026	020418201608	0.27 in	2.76 in	0.39 in	0.44 in	0.39 in	Bulk	160 lb	0.10 lb	10	100
7/16 in	T7645036	020418201615	0.31 in	3.17 in	0.42 in	0.51 in	0.41 in	Bulk	200 lb	0.15 lb	10	100
1/2 in	T7645046	020418201622	0.35 in	3.60 in	0.47 in	0.56 in	0.40 in	Bulk	230 lb	0.20 lb	10	100
5/8 in	T7645066	020418201639	0.39 in	4.01 in	0.55 in	0.65 in	0.49 in	Bulk	280 lb	0.28 lb	10	100
1 in	T7645074	020418204777	0.46 in	5.48 in	0.87 in	0.72 in	0.50 in	Bulk	400 lb	0.59 lb	10	50

Quick Links

- For Fast and Easy Connections Between Two Lengths of Chain
- Zinc Plated Finish
- DO NOT EXCEED THE WORKING LOAD LIMIT
- Do Not Use for Overhead Lifting or Hoisting
- Do Not Use to Support Human Weight, for Playground or Athletic Equipment, or as a Safety Device

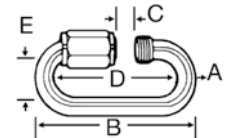
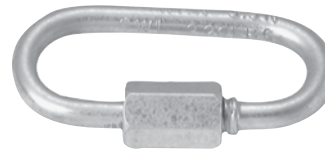

Trade Size	Cat. No.	UPC No.	(A) Material Diameter	(B) Length	(C) Opening	(D) Inside Length	(E) Inside Width	Packaging	Working Limit	Weight Each	Shelf Pack	Case Pack
1/8 in	T7645106V	020418269806	0.13 in	1.40 in	0.20 in	1.16 in	0.40 in	Bulk	220 lb	0.02 lb	10	100
3/16 in	T7645116V	020418269875	0.20 in	1.85 in	0.29 in	1.60 in	0.53 in	Bulk	660 lb	0.05 lb	10	100
1/4 in	T7645126V	020418269813	0.24 in	2.31 in	0.34 in	1.85 in	0.58 in	Bulk	880 lb	0.08 lb	10	100
5/16 in	T7645136V	020418269783	0.31 in	2.92 in	0.41 in	2.31 in	0.74 in	Bulk	1760 lb	0.15 lb	10	100
3/8 in	T7645146V	020418269820	0.35 in	3.21 in	0.45 in	2.53 in	0.81 in	Bulk	2200 lb	0.24 lb	10	100
1/2 in	T7645156V	020418269905	0.47 in	4.17 in	0.57 in	3.27 in	0.94 in	Bulk	3300 lb	0.50 lb	10	50



Stainless Steel Spring Snap Links

- Ideal for Hanging Keys and Other Utility Items From Belt
- Fast and Easy to Connect and Disconnect
- Polished Finish
- DO NOT EXCEED THE WORKING LOAD LIMIT
- Do Not Use for Overhead Lifting or Hoisting
- Do Not Use to Support Human Weight, for Playground or Athletic Equipment, or as a Safety Device

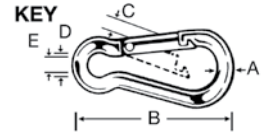

Trade Size	Cat. No.	UPC No.	(A) Material Diameter	(B) Length	(C) Opening	(D) Inside Length	(E) Inside Width	Packaging	Working Load Limit	Weight Each	Shelf Pack	Case Pack
1/4 in	T7630406	020418193415	0.226 in	2.38 in	0.34 in	0.37 in	0.29 in	Bulk	160 lb	0.06 lb	10	100
5/16 in	T7630416	020418193422	0.305 in	3.15 in	0.45 in	0.51 in	0.40 in	Bulk	200 lb	0.14 lb	10	100
3/8 in	T7630426	020418193439	0.340 in	3.54 in	0.45 in	0.57 in	0.45 in	Bulk	260 lb	0.20 lb	10	100
7/16 in	T7630436	020418193446	0.385 in	3.94 in	0.51 in	0.66 in	0.46 in	Bulk	320 lb	0.28 lb	10	100
1/2 in	T7630446	020418193453	0.420 in	4.69 in	0.66 in	0.75 in	0.60 in	Bulk	450 lb	0.42 lb	10	50

Stainless Steel Quick Links

- For Fast and Easy Connections Between Two Lengths of Chain
- Polished Finish
- DO NOT EXCEED THE WORKING LOAD LIMIT
- Do Not Use for Overhead Lifting or Hoisting
- Do Not Use to Support Human Weight, for Playground or Athletic Equipment, or as a Safety Device

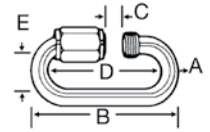
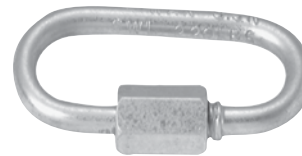

Trade Size	Cat. No.	UPC No.	(A) Material Diameter	(B) Length	(C) Opening	(D) Inside Length	(E) Inside Width	Packaging	Working Load Limit	Weight Each	Shelf Pack	Case Pack
1/8 in	T7630506	020418193460	0.137 in	1.45 in	0.19 in	1.18 in	0.41 in	Bulk	220 lb	0.02 lb	10	100
3/16 in	T7630526	020418193477	0.195 in	1.94 in	0.24 in	1.56 in	0.53 in	Bulk	660 lb	0.04 lb	10	100
1/4 in	T7630536	020418193484	0.230 in	2.28 in	0.30 in	1.83 in	0.60 in	Bulk	880 lb	0.08 lb	10	100
5/16 in	T7630546	020418193491	0.310 in	2.93 in	0.38 in	2.34 in	0.73 in	Bulk	1540 lb	0.18 lb	10	100
3/8 in	T7630556	020418193507	0.350 in	3.24 in	0.39 in	2.56 in	0.78 in	Bulk	1540 lb	0.24 lb	10	100

Die Cast Zinc Pulleys

- Features One Piece Cast Construction
- Solid Brass or Brass Plated Sheaves
- Nickel Plated Finish
- For Rope Applications in Awnings, Flagpoles and Other Light Duty Applications
- DO NOT EXCEED THE WORKING LOAD LIMIT
- Do Not Use for Overhead Lifting or Hoisting
- Do Not Use to Support Human Weight, for Playground or Athletic Equipment, or as a Safety Device



Figure No.	Trade Size	Cat. No.	UPC No.	Style	Rope Size	Sheave Size - OD	Eye Size	Packaging	Working Load Limit	Weight Each	Shelf Pack	Case Pack
0173	1/2 in	T7655052N	020418318306	Swivel Eye, Single Sheave	3/16	1/2 in	5/16 in	Bulk	25 lb	0.042 lb	10	100
0174	1/2 in	T7655062N	020418318368	Rigid Eye, Single Sheave	3/16	1/2 in	3/16 in	Bulk	30 lb	0.033 lb	10	100
0173	3/4 in	T7655002N	020418318313	Swivel Eye, Single Sheave	1/4 in	3/4 in	5/16 in	Bulk	25 lb	0.062 lb	10	100
0174	3/4 in	T7655100N	020418318375	Rigid Eye, Single Sheave	1/4 in	3/4 in	3/16 in	Bulk	30 lb	0.046 lb	10	100
0176	3/4 in	T7655202N	020418318429	Rigid Eye, Double Sheave	1/4 in	3/4 in	3/16 in	Bulk	40 lb	0.073 lb	10	100
0173	1 in	T7655012N	020418318320	Swivel Eye, Single Sheave	5/16 in	1 in	5/16 in	Bulk	30 lb	0.097 lb	10	100
0174	1 in	T7655112N	020418318382	Rigid Eye, Single Sheave	5/16 in	1 in	7/32 in	Bulk	55 lb	0.088 lb	10	100
0176	1 in	T7655212N	020418318436	Rigid Eye, Double Sheave	5/16 in	1 in	7/32 in	Bulk	55 lb	0.150 lb	10	100
0173	1-1/4 in	T7655022N	020418318337	Swivel Eye, Single Sheave	3/8 in	1-1/4 in	5/8 in	Bulk	50 lb	0.172 lb	10	100
0174	1-1/4 in	T7655120N	020418318399	Rigid Eye, Single Sheave	3/8 in	1-1/4 in	3/8 in	Bulk	110 lb	0.139 lb	10	100
0173	1-1/2 in	T7655032N	020418318344	Swivel Eye, Single Sheave	3/8 in	1-1/2 in	5/8 in	Bulk	50 lb	0.212 lb	10	50
0174	1-1/2 in	T7655132N	020418318405	Rigid Eye, Single Sheave	3/8 in	1-1/2 in	3/8 in	Bulk	110 lb	0.154 lb	10	100
0173	2 in	T7655042N	020418318351	Swivel Eye, Single Sheave	1/2 in	2 in	5/8 in	Bulk	55 lb	0.360 lb	10	100
0174	2 in	T7655142N	020418318412	Rigid Eye, Single Sheave	1/2 in	2 in	15/32 in	Bulk	125 lb	0.367 lb	10	100



Heavy Duty Steel Pulleys

- Steel Body and Die-Cast Zinc Sheave
- Zinc Plated to Protect Against Rust and Corrosion
- Powder Metal Bushing to Extend Pulley Life and Provide Smooth Operation
- For Rope Up to 3/8" or 1/2" As Noted
- Working Load Limit Stamped on Pulley Body
- For Indoor or Outdoor Use
- Mount Wall and Ceiling Pulleys with 4D or 6D Nails or #4 X 3/4" Screws
- DO NOT EXCEED THE WORKING LOAD LIMIT
- Do Not Use for Overhead Lifting or Hoisting



ACCESSORIES

Trade Size	Cat. No.	UPC No.	Style	Finish	Rope Size	Sheave Size - OD	Packaging	Working Load Limit	Weight Each	Shelf Pack	Case Pack
1-1/2 in	T7550301	020418193361	Swivel Eye, Single Sheave	Zinc Plated	3/8 in	1-1/2 in	Bulk	420 lb	0.32 lb	5	50
1-1/2 in	T7550401	020418193392	Fixed Eye, Single Sheave	Zinc Plated	3/8 in	1-1/2 in	Bulk	420 lb	0.18 lb	5	50
1-1/2 in	T7550421	020418193385	Fixed Eye, Double Sheave	Zinc Plated	3/8 in	1-1/2 in	Bulk	400 lb	0.30 lb	5	50
1-1/2 in	T7550501	020418300028	Wall/Ceiling Mount, Single Sheave	Zinc Plated	3/8 in	1-1/2 in	Bulk	100 lb	0.33 lb	5	50
2 in	T7550302	020418193378	Swivel Eye, Single Sheave	Zinc Plated	3/8 in	2 in	Bulk	480 lb	0.22 lb	5	50
2 in	T7550402	020418193408	Fixed Eye, Single Sheave	Zinc Plated	3/8 in	2 in	Bulk	480 lb	0.26 lb	5	50
2 in	T7550502	020418300011	Wall/Ceiling Mount, Single Sheave	Zinc Plated	3/8 in	2 in	Bulk	100 lb	0.46 lb	5	50
2 in	T7551522	020418300004	Joist Mount, Single Sheave	Zinc Plated	3/8 in	2 in	Bulk	100 lb	0.45 lb	5	50
2-1/2 in	T7550303	020418206085	Swivel Eye, Single Sheave	Zinc Plated	3/8 in	2-1/2 in	Bulk	550 lb	0.62 lb	5	25
2-1/2 in	T7550403	020418300035	Fixed Eye, Single Sheave	Zinc Plated	3/8 in	2-1/2 in	Bulk	550 lb	0.70 lb	5	25
3 in	T7550304	020418300059	Swivel Eye, Single Sheave	Zinc Plated	1/2 in	3 in	Bulk	650 lb	1.05 lb	5	25
3 in	T7550404	020418300042	Fixed Eye, Single Sheave	Zinc Plated	1/2 in	3 in	Bulk	650 lb	1.03 lb	5	25

Rope Clamps

- Used to Create Loop End Termination on Fiber Rope



Cat. No.	UPC No.	Style	Finish	Rope Size	Packaging	Weight Each	Shelf Pack	Case Pack
B7679034	020418157189	Rope Clamp, 2 per Bag	Zinc Plated	1/2 in	Bagged	0.10 lb	10	100

Rope Cleats

- For Fastening Rope for Boats, Awnings, Etc.



Figure No.	Trade Size	Cat. No.	UPC No.	Finish	Length	Packaging	Weight Each	Shelf Pack	Case Pack
4015	2-1/2 in	T7655402-02	020418370250	Nickel Plated	2.5 in	Bulk	0.04 lb	10	100
4015	2-1/2 in	T7655404	020418193354	Brass Plated	2.5 in	Bulk	0.03 lb	10	100
4015	4-1/2 in	T7655412-02	020418370267	Nickel Plated	4.5 in	Bulk	0.08 lb	10	100
4015	6 in	T7655422-02	020418370274	Nickel Plated	6 in	Bulk	0.14 lb	10	100

Ferrules and Stops

- Insert Ferrule(s) Onto Cable, Form Loop and Insert Thimble (If Desired)
- Use a Proper Swaging Tool (Not a Hammer) to Make Swages.
- Match Ferrule, Thimble and Stop Size to Size of Cable
- If Used on Coated Cable, Remove the Coating From the Assembly Area
- Follow Assembly Instructions Carefully
- Made From Aluminum

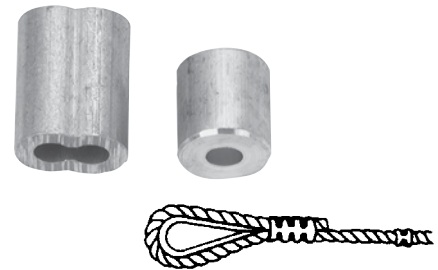

Trade Size	Cat. No.	UPC No.	Material	For Cable Diameter	Style	Packaging	Weight Each	Shelf Pack	Case Pack
1/16 in	7670804	020418288142	Aluminum	1/16 in	Ferrules	Bulk	0.01 lb	50	250
1/16 in	B7675404	020418288197	Aluminum	1/16 in	Ferrules (2) and Stops (2)	Bagged	0.01 lb	10	100
3/32 in	7670814	020418288159	Aluminum	3/32 in	Ferrules	Bulk	0.01 lb	50	250
3/32 in	B7675414	020418288203	Aluminum	3/32 in	Ferrules (2) and Stops (2)	Bagged	0.02 lb	10	100
1/8 in	7670824	020418288166	Aluminum	1/8 in	Ferrules	Bulk	0.01 lb	50	250
1/8 in	B7675424	020418288210	Aluminum	1/8 in	Ferrules (2) and Stops (2)	Bagged	0.02 lb	10	100
3/16 in	7670844	020418288173	Aluminum	3/16 in	Ferrules	Bulk	0.02 lb	50	250
3/16 in	B7675444	020418288227	Aluminum	3/16 in	Ferrules (2) and Stops (2)	Bagged	0.04 lb	10	100
1/4 in	7670854	020418288180	Aluminum	1/4 in	Ferrules	Bulk	0.03 lb	50	250
1/4 in	B7675454	020418288234	Aluminum	1/4 in	Ferrules (2) and Stops (2)	Bagged	0.09 lb	10	100

Swaging Tool

- For Securing Ferrules and Stops onto Wire Rope or Cable
- Do Not Swage on Coated Cable, Remove Coating From the Assembly Area
- Read All Assembly and Maintenance Instructions on Tool Package
- Designed for Use on 1/16" to 3/16" Sized Ferrules and Stops



Cat. No.	UPC No.	Overall Length	Packaging	Weight Each
7679038	020418224010	18.0 in	Boxed	5.90 lb



Wire Rope Clips and Thimbles

- If Used on Coated Cable, Remove the Coating From the Assembly Area
- Electro-Galvanized Finish
- Follow Assembly Instructions

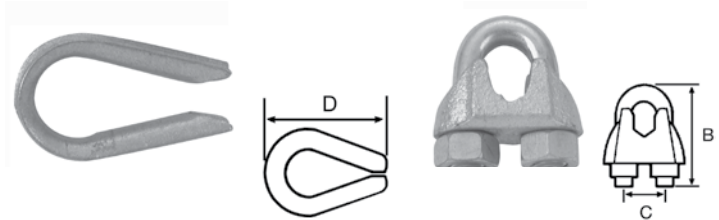

Figure No.	Trade Size	Cat. No.	UPC No.	Style	Finish	A Dim.	B Dim.	C Dim.	D Dim.	Packaging	Weight Each	Shelf Pack	Case Pack
3300	1/16 in	T7670409	020418192586	Wire Rope Clip	Electro-Galvanized	1/16 in	7/8 in	7/16 in		Bulk	0.02 lb	10	100
3300	1/8 in	B7675109	020418166846	Wire Rope Clips (2) w/ Thimble (1)	Electro-Galvanized	1/8 in	1-1/2 in	1/2 in	1-3/4 in	Bagged	0.18 lb	10	100
3300	1/8 in	T7670419	020418201691	Wire Rope Clip	Electro-Galvanized	3/32 in - 1/8 in	1 in	1/2 in		Bulk	0.03 lb	10	100
323	1/8 in	T7670609	020418201769	Wire Rope Thimble	Electro-Galvanized	3/32 in - 1/8 in			1-3/4 in	Bulk	0.03 lb	10	100
3300	3/16 in	B7675119	020418166853	Wire Rope Clips (2) w/ Thimble (1)	Electro-Galvanized	3/16 in	1-1/16 in	9/16 in	1-3/4 in	Bagged	0.19 lb	10	100
3300	3/16 in	T7670429	020418201707	Wire Rope Clip	Electro-Galvanized	3/16 in	1-1/16 in	9/16 in		Bulk	0.05 lb	10	100
323	3/16 in	T7670619	020418201776	Wire Rope Thimble	Electro-Galvanized	3/16 in			1-3/4 in	Bulk	0.02 lb	10	100
3300	1/4 in	B7675129	020418166860	Wire Rope Clips (2) w/ Thimble (1)	Electro-Galvanized	1/4 in	1-1/2 in	11/16 in	1-7/8 in	Bagged	0.20 lb	10	100
3300	1/4 in	T7670439	020418201714	Wire Rope Clip	Electro-Galvanized	1/4 in	1-1/2 in	11/16 in		Bulk	0.10 lb	10	100
323	1/4 in	T7670629	020418201783	Wire Rope Thimble	Electro-Galvanized	1/4 in			1-7/8 in	Bulk	0.03 lb	10	100
3300	5/16 in	T7670449	020418201721	Wire Rope Clip	Electro-Galvanized	5/16 in	1-1/2 in	11/16 in		Bulk	0.13 lb	10	100
323	5/16 in	T7670639	020418201790	Wire Rope Thimble	Electro-Galvanized	5/16 in			2-3/32 in	Bulk	0.04 lb	10	100
3300	3/8 in	T7670459	020418201738	Wire Rope Clip	Electro-Galvanized	3/8 in	2 in	7/8 in		Bulk	0.22 lb	10	10
323	3/8 in	T7670649	020418201806	Wire Rope Thimble	Electro-Galvanized	3/8 in			2-1/4 in	Bulk	0.06 lb	10	100
3300	1/2 in	T7670479	020418201745	Wire Rope Clip	Electro-Galvanized	1/2 in	2-1/2 in	1 in		Bulk	0.31 lb	5	50
323	1/2 in	T7670659	020418201813	Wire Rope Thimble	Electro-Galvanized	1/2 in			2-1/2 in	Bulk	0.11 lb	5	50
3300	5/8 in	T7670489	020418201752	Wire Rope Clip	Electro-Galvanized	5/8 in	2-3/4 in	1-3/16 in		Bulk	0.26 lb	5	50
323	5/8 in	T7670669	020418201820	Wire Rope Thimble	Electro-Galvanized	5/8 in			2-7/8 in	Bulk	0.34 lb	5	50
3300	3/4 in	T7670499	020418180460	Wire Rope Clip	Electro-Galvanized	3/4 in	3-1/16 in	1-11/32 in		Bulk	0.60 lb	5	50

ACCESSORIES

Stainless Steel Wire Rope Clips & Light Duty Thimbles

- If Used on Coated Cable, Remove the Coating From the Assembly Area
- Follow Assembly Instructions



Trade Size	Cat. No.	UPC No.	Finish	Style	Finish	Packaging	Weight Each	Shelf Pack	Case Pack
1/8 in	T7633002	020418204692	Polished	Wire Rope Clip	Polished	Bulk	0.03 lb	10	100
3/16 in	T7633003	020418204715	Polished	Wire Rope Clip	Polished	Bulk	0.05 lb	10	100
1/4 in	T7633004	020418204722	Polished	Wire Rope Clip	Polished	Bulk	0.08 lb	10	100
1/16 in - 1/8 in	T7637502	020418238147	Polished	Wire Rope Thimble	Polished	Bulk	0.02 lb	10	100
3/16 in	T7637503	020418204746	Polished	Wire Rope Thimble	Polished	Bulk	0.02 lb	10	100
1/4 in	T7637504	020418204753	Polished	Wire Rope Thimble	Polished	Bulk	0.02 lb	10	100

ACCESSORIES

Eye & Eye Swivels (Import)

- Forged Steel
- These Swivels ARE NOT Designed to Swivel Under Load
- UPC Tagged
- DO NOT EXCEED THE WORKING LOAD LIMIT



Trade Size	Cat. No.	UPC No.	Finish	A Dim.	B Dim.	C Dim.	D Dim.	E Dim.	F Dim.	Working Load Limit	Weight Each	Shelf Pack	Case Pack
3/16 in	T9630335	020418211560	Galvanized	0.20 in	0.70 in	0.81 in	2.52 in	0.62 in	0.64 in	700 lb	0.11 lb	5	50
1/4 in	T9630435	020418211577	Galvanized	0.25 in	0.73 in	1.02 in	3.00 in	0.65 in	0.69 in	850 lb	0.19 lb	5	50
5/16 in	T9630535	020418211584	Galvanized	0.33 in	0.97 in	1.18 in	3.64 in	0.77 in	0.84 in	1250 lb	0.37 lb	5	50
3/8 in	T9630635	020418211591	Galvanized	0.44 in	1.20 in	1.34 in	4.20 in	1.00 in	1.02 in	2250 lb	0.69 lb	5	25
1/2 in	T9630835	020418211607	Galvanized	0.55 in	1.46 in	1.88 in	5.44 in	1.16 in	1.28 in	3600 lb	1.39 lb	5	25

Anchor Shackles, Screw Pin (Import) Consumer Grade

- Carbon Steel
- Zinc Plated
- DO NOT EXCEED THE WORKING LOAD LIMIT
- Do Not Use for Overhead Lifting or Hoisting

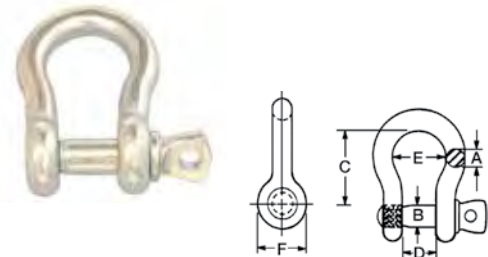

Trade Size	Cat. No.	UPC No.	Style	A Dim.	B Dim.	C Dim.	D Dim.	E Dim.	F Dim.	Working Load Limit	Weight Each	Shelf Pack	Case Pack
3/16 in	T9600335	020418201509	Screw Pin	0.20 in	0.21 in	0.92 in	0.38 in	0.67 in	0.45 in	100 lb	0.05 lb	10	100
1/4 in	T9600435	020418201516	Screw Pin	0.24 in	0.29 in	0.98 in	0.53 in	0.77 in	0.55 in	400 lb	0.08 lb	10	100
5/16 in	T9600535	020418201523	Screw Pin	0.28 in	0.37 in	1.20 in	0.59 in	0.90 in	0.66 in	700 lb	0.15 lb	10	100
3/8 in	T9600635	020418201530	Screw Pin	0.35 in	0.45 in	1.43 in	0.70 in	1.04 in	0.80 in	1000 lb	0.28 lb	10	100
1/2 in	T9600835	020418201547	Screw Pin	0.43 in	0.52 in	1.82 in	0.84 in	1.28 in	0.96 in	2000 lb	0.60 lb	5	50

(continued)



Anchor Shackles, Screw Pin (Import) Consumer Grade *(continued from previous page)*

Trade Size	Cat. No.	UPC No.	Style	A Dim.	B Dim.	C Dim.	D Dim.	E Dim.	F Dim.	Working Load Limit	Weight Each	Shelf Pack	Case Pack
5/8 in	T9601035	020418201554	Screw Pin	0.60 in	0.74 in	2.25 in	1.17 in	1.67 in	1.32 in	3000 lb	1.40 lb	5	20
3/4 in	T9601235	020418201561	Screw Pin	0.75 in	0.83 in	2.76 in	1.25 in	1.95 in	1.60 in	4000 lb	2.40 lb	5	20
1 in	T9601635	020418201578	Screw Pin	0.94 in	1.06 in	3.71 in	1.70 in	2.75 in	2.00 in	5000 lb	5.00 lb	2	10

Anchor Shackles, Screw Pin (Import) Industrial Grade

- Drop-Forged Carbon Steel
- Galvanized Finish
- DO NOT EXCEED THE WORKING LOAD LIMIT

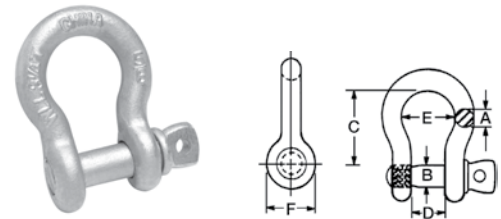

Trade Size	Cat. No.	UPC No.	Finish	A Dim.	B Dim.	C Dim.	D Dim.	E Dim.	F Dim.	WLL (Short Tons)	Weight Each	Shelf Pack	Case Pack
3/16 in	T9640335	020418211706	Galvanized	0.19 in	0.25 in	0.87 in	0.37 in	0.63 in	0.56 in	1/3 t	0.06 lb	10	100
1/4 in	T9640435	020418211683	Galvanized	0.25 in	0.31 in	1.12 in	0.50 in	0.78 in	0.69 in	1/2 t	0.11 lb	10	100
5/16 in	T9640535	020418211676	Galvanized	0.32 in	0.37 in	1.20 in	0.54 in	0.83 in	0.86 in	3/4 t	0.18 lb	10	100
3/8 in	T9640635	020418211669	Galvanized	0.38 in	0.43 in	1.44 in	0.67 in	1.00 in	1.05 in	1 t	0.32 lb	10	100
1/2 in	T9640835	020418211652	Galvanized	0.50 in	0.62 in	1.86 in	0.86 in	1.30 in	1.20 in	2 t	0.69 lb	5	50
5/8 in	T9641035	020418211645	Galvanized	0.62 in	0.75 in	2.44 in	1.06 in	1.56 in	1.52 in	3-1/4 t	1.50 lb	25	25
3/4 in	T9641235	020418211621	Galvanized	0.75 in	0.87 in	2.80 in	1.30 in	2.00 in	1.85 in	4-3/4 t	2.30 lb	15	15
7/8 in	T9641435	020418211638	Galvanized	0.90 in	1.00 in	3.20 in	1.43 in	2.15 in	2.00 in	6-1/2 t	3.35 lb	10	10
1 in	T9641635	020418211614	Galvanized	1.00 in	1.12 in	3.75 in	1.68 in	2.55 in	2.37 in	8-1/2 t	5.20 lb	5	5

Eye Grab Hooks, Grade 43, (Import)

- Grade 43 Forged Steel
- Grab Hooks Are Designed to Grab a Chain Link and Hold it in Place
- DO NOT EXCEED THE WORKING LOAD LIMIT



Trade Size	Cat. No.	UPC No.	Hook Style	Finish	Working Load Limit	Weight Each	Shelf Pack	Case Pack
1/4 in	T9001424	020418222139	Eye	Zinc Plated	2600 lb	0.34 lb	10	100
5/16 in	T9001524	020418222146	Eye	Zinc Plated	3900 lb	0.55 lb	10	50
3/8 in	T9001624	020418222153	Eye	Zinc Plated	5400 lb	0.90 lb	10	50
1/2 in	T9001824	020418222122	Eye	Zinc Plated	9200 lb	1.80 lb	5	20

Clevis Grab Hooks, Grade 43, (Import)

- Grade 43 Forged Steel
- Grab Hooks Are Designed to Grab a Chain Link and Hold it in Place
- Hooks are Sized by the Material Diameter of the Chain That They Engage. Make Sure the Hook Size and Chain Diameter are Compatible Before Attaching to Load
- DO NOT EXCEED THE WORKING LOAD LIMIT



Trade Size	Cat. No.	UPC No.	For Chain Size	Hook Style	Finish	Working Load Limit	Weight Each	Shelf Pack	Case Pack
1/4 in	T9501424	020418192678	1/4 in	Clevis	Zinc Plated	2600 lb	0.43 lb	10	100
5/16 in	T9501524	020418192685	5/16 in	Clevis	Zinc Plated	3900 lb	0.73 lb	10	50
3/8 in	T9501624	020418192692	3/8 in	Clevis	Zinc Plated	5400 lb	1.11 lb	10	50
1/2 in	T9501824	020418220661	1/2 in	Clevis	Zinc Plated	9200 lb	1.85 lb	5	20

Clevis Grab Hooks, Grade 70, (Import)

- Forged Steel
- Transport Grade
- Grab Hooks Are Designed to Grab a Chain Link and Hold it in Place
- Hooks are Sized by the Material Diameter of the Chain That They Engage. Make Sure the Hook Size and Chain Diameter are Compatible Before Attaching to Load



Trade Size	Cat. No.	UPC No.	For Chain Size	Hook Style	Finish	Working Load Limit	Weight Each	Shelf Pack	Case Pack
1/4 in	T9503315	020418289316	1/4 in	Clevis	Yellow Chromate	3150 lb	0.43 lb	10	100
5/16 in	T9503415	020418201974	5/16 in	Clevis	Yellow Chromate	4700 lb	0.71 lb	10	50
3/8 in	T9503515	020418201981	3/8 in	Clevis	Yellow Chromate	6600 lb	1.18 lb	5	25

Eye Slip Hooks, Grade 43, (Import)

- UPC Tagged Forged Steel
- Slip Hooks Are Designed to Allow Chain to Slip Through the Hook
- DO NOT EXCEED THE WORKING LOAD LIMIT



Trade Size	Cat. No.	UPC No.	Hook Style	Finish	Working Load Limit	Weight Each	Shelf Pack	Case Pack
1/4 in	T9101424	020418222177	Eye	Zinc Plated	2600 lb	0.40 lb	10	100
5/16 in	T9101524	020418222184	Eye	Zinc Plated	3900 lb	0.70 lb	10	50
3/8 in	T9101624	020418222191	Eye	Zinc Plated	5400 lb	1.00 lb	10	50
1/2 in	T9101824	020418222160	Eye	Zinc Plated	9200 lb	2.60 lb	5	20



Clevis Slip Hooks, Grade 43, (Import)

- Grade 43 Forged Steel
- Slip Hooks Are Designed to Allow Chain to Slip Through the Hook
- Hooks are Sized by the Material Diameter of the Chain That They Engage. Make Sure the Hook Size and Chain Diameter are Compatible Before Attaching to Load

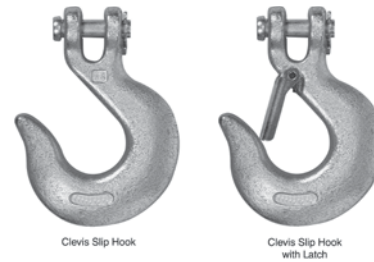

Trade Size	Cat. No.	UPC No.	For Chain Size	Hook Style	Finish	Working Load Limit	Weight Each	Shelf Pack	Case Pack
1/4 in	T9401424	020418192647	1/4 in	Clevis	Zinc Plated	2600 lb	0.55 lb	5	100
1/4 in	T9700424	020418192081	1/4 in	Clevis w/ Latch	Zinc Plated	2600 lb	0.65 lb	5	50
5/16 in	T9401524	020418192654	5/16 in	Clevis	Zinc Plated	3900 lb	0.79 lb	5	50
5/16 in	T9700524	020418192098	5/16 in	Clevis w/ Latch	Zinc Plated	3900 lb	0.85 lb	5	50
3/8 in	T9401624	020418192661	3/8 in	Clevis	Zinc Plated	5400 lb	1.41 lb	5	50
3/8 in	T9700624	020418192104	3/8 in	Clevis w/ Latch	Zinc Plated	5400 lb	1.41 lb	5	30
1/2 in	T9401824	020418220654	1/2 in	Clevis	Zinc Plated	9200 lb	2.87 lb	5	15
1/2 in	T9700824	020418220647	1/2 in	Clevis w/ Latch	Zinc Plated	9200 lb	2.88 lb	5	15

ACCESSORIES

Clevis Slip Hooks, Grade 70, (Import)

- Forged Steel
- Transport Grade
- Slip Hooks Are Designed to Allow Chain to Slip Through the Hook
- Hooks are Sized by the Material Diameter of the Chain That They Engage. Make Sure the Hook Size and Chain Diameter are Compatible Before Attaching to Load



Trade Size	Cat. No.	UPC No.	For Chain Size	Hook Style	Finish	Working Load Limit	Weight Each	Shelf Pack	Case Pack
1/4 in	T9504315	020418289323	1/4 in	Clevis w/ Latch	Yellow Chromate	3150 lb	0.65 lb	5	50
5/16 in	T9504415	020418289330	5/16 in	Clevis w/ Latch	Yellow Chromate	4700 lb	0.85 lb	5	50
3/8 in	T9504515	020418289347	3/8 in	Clevis w/ Latch	Yellow Chromate	6600 lb	1.41 lb	5	30



FITTINGS

Shackles	65
Hoist Hooks.....	71
Clevis Hooks	75
Latch Kits.....	78
Swivels	79
Thimbles	80
Eyebolts	81





Carbon and Alloy Steel Fittings Standards

The Hillman Group forges Campbell® fittings under established quality control procedures. Dimensional tolerances meet standards adopted by the Drop Forging Association as outlined in “Standard Practices and Tolerances for Impression Die Forgings.” Working load limits for carbon and alloy steel fittings are based on predetermined design factors.

Working Load Limit. This is the related capacity. It is the maximum load which should ever be applied to the fittings in service, even when they are new.

Proof Test. This is a term designating a quality control tensile test applied to the fitting during or subsequent to the process of manufacture. It is the minimum force in pounds which the fitting has withstood in the condition and at the time it left the factory, under a test in which a constantly increasing force has been applied in direct tension to the fitting on a standard test machine.

Ton. Where “ton” is used in this catalog, it refers to short ton or 2,000 pounds, unless otherwise noted.

Key to Figure Number Designations

S-Painted Blue	H- Heat Treated
G-Galvanized	ST-Stainless Steel
C-Carbon	V- Electro-polished
A-Alloy	Z- Zinc Plated
O-Painted Orange	

WARNING: Do not exceed Working Load Limit. Most of the fittings in this catalog are intended to be used in conjunction with other components in a load sustaining system. Care should be taken to select components of compatible type, grade, size and working load limit. Any abuse, misuse or alteration of the fitting may lessen the load that the fitting will sustain. Some examples of such changes and abuses are as follows:

- Twisting or side loading.
- Disfigurement.
- Deterioration of the fitting caused by strain, usage or corrosion.
- Shock loading.
- Use for a purpose other than that for which the particular fitting was intended.
- Use to carry a load in excess of the Working Load Limit.

A continual inspection program should be undertaken to discover gouges, distortion, cracks, elongation or stretching, spread in the throat, opening of hooks, severe wear, or other damage. The Hillman Group does not accept any liability for damages which may result from alteration, misuse or abuse of the product or from use in excess of the Working Load Limit.

NOTICE: The product specifications and dimensions are as accurate as possible at the time of printing. However, because we are constantly improving the quality and design of our products, they can change without notice.

ADVERTENCIA

Para prevenir la posibilidad de una lesión personal sería:

- **NO EXCEDA** los límites de carga de las cadenas o componentes.
- **NO LA UTILICE** para cargar hacia arriba o para izar.
- **NO LA UTILICE** si la cadena o los componentes están visualmente distorsionados o gastados.

WARNING

To prevent the possibility of serious bodily injury:

- **DO NOT EXCEED** the working load limits for chain or components.
- **DO NOT USE** for overhead lifting or hoisting.
- **DO NOT USE** if the chain or components are visibly distorted or worn.

Shackles

(1st letter indicates material, number is type, last letter indicates finish)

Screw Pin Anchor C-419-S, C-419-G, A-419-G
Bolt Type Anchor C-999-G, A-999-G

READ AND UNDERSTAND THESE WARNINGS AND INSTRUCTIONS BEFORE USING SHACKLES.



BOLT TYPE PIN ANCHOR SHACKLE



SCREW PIN ANCHOR SHACKLE

Campbell carbon and alloy steel shackles are drop-forged. All pins and bolts are galvanized and made of alloy steel. The shackles meet the design requirements of Federal Specification RR-C-271, Type IV. Galvanizing meets ASTM A-153 specification. Self-colored shackles are painted blue for identification purposes.

WARNING

- Failure to follow the instructions for use and these warnings may cause death or serious injury.
- Use shackles only as indicated.
- Shackles must always be inspected for wear, distortion and damage before use. If the pin or bow is worn, distorted or damaged, discard the entire shackle and replace.
- Do not use round pin shackles in rigging applications.
- Screw pin shackles should not be used if there will be movement on the pin. Movement could cause the pin to unscrew and drop the load.
- Screw pin should be tightened prior to use.
- Always stand clear of loads being lifted.

IMPORTANT: Instructions For Use

1. Do not exceed working load limit (WLL). See tables below.
2. The standard WLL given applies to in-line loading (perpendicular to the pin). When the loading is at an angle, the WLL is reduced as shown in the table below.
3. Any angular loads must be on the bow. All straight loading should be on the pin.

Working Load Limit in Tons Campbell Carbon & Alloy Shackles

Shackle Size		In-Line Load WLL		45° Load WLL 30% Loss		90° Load WLL 50% Loss	
Inches	mm	Ton*	kg	Ton*	kg	Ton*	kg
3/16"	5	1/3	302	1/5	181	1/6	151
1/4"	6	1/2	454	1/3	302	1/4	227
5/16"	8	3/4	680	1/2	454	1/3	302
3/8"	10	1	907	2/3	605	1/2	454
3/8" Alloy*	10	2	2000	1-1/3	1400	1	1000
7/16"	11	1-1/2	1361	1	907	3/4	680
1/2"	13	2	1814	1-1/3	1210	1	907
1/2" Alloy*	13	3-1/4	3250	2-1/3	2333	1-1/2	1500
5/8"	16	3-1/4	2948	2-1/4	2041	1-1/2	1361
5/8" Alloy*	16	5	5000	3-1/2	3500	2-1/2	2500
3/4"	19	4-3/4	4309	3-1/3	3024	2-1/3	2117
3/4" Alloy*	19	7	7000	5	5000	3-1/2	3500
7/8"	22	6-1/2	5897	4-1/2	4082	3-1/4	2948
7/8" Alloy*	22	9-1/2	9500	6 2/3	6667	4-3/4	4750
1"	25	8-1/2	7711	6	5443	4-1/4	3856
1" Alloy*	25	12-1/2	12500	8-3/4	8750	6-1/4	6250
1-1/8"	29	9-1/2	8618	6-2/3	6048	4-3/4	4309
1-1/4"	32	12	10886	8-1/3	7560	6	5443
1-1/4" Alloy*	32	18	18000	12-1/2	12500	9	9000
1-3/8"	35	13-1/2	12247	9-1/2	8618	6-3/4	6123
1-3/8" Alloy*	35	21	21000	14-3/4	14750	10-1/2	10500
1-1/2"	38	17	15422	11-7/8	10773	8-1/2	7711
1-1/2" Alloy*	38	30	30000	21	21000	15	15000
1-3/4"	44	25	22680	17-1/2	15876	12-1/2	11340
1-3/4" Alloy*	44	40	40000	28	28000	20	20000
2"	51	35	31751	24-1/2	22226	17-1/2	15876
2" Alloy*	51	55	55000	38-1/2	38500	27-1/2	27500
2-1/2"	64	55	49895	38-1/2	34926	27-1/2	24947
2-1/2" Alloy*	64	85	85000	59-1/2	59500	42-1/2	42500

*Alloy Shackles are rated in Metric Tons

FITTINGS



Carbon Bolt Type Anchor Shackles, Galvanized, C-999-G

- Shackle Bodies Are Drop-Forged Carbon Steel
- Galvanized to Meet ASTM A-153 Specifications
- C-999-G Shackles Meet the Design Requirements of Federal Specification RR-C-271, Type IVA, Grade A, Class 3
- Working Load Limit, Size, Manufacture Name, Date Code and USA Permanently Marked on Each Shackle
- Statistically Tested for Impact Resistance, Tensile Strength, Hardness, Ductility and Fatigue
- 999 Series Shackles Meet or Exceed All Manufacturing Requirements of the ASME B30.26 "Rigging Hardware". These Include the Material Ductility Requirement (Section 26-1.1.2), the Design Factor Requirement (Section 26.1.2), the Identification Requirement (Section 26-1.5.1), and the Effective Temperature Range (Section 26-1.6.1).
- The Shackles Can Be Proof Tested in Accordance with Section 26-1.4 upon request
- Certification Available Upon Request
- 6 to 1 Design Factor on Shackles 1/4" to 2"
- 5 to 1 Design Factor on 2-1/2"
- Pins and Bolts Are Heat-Treated and Made of Alloy Steel
- DO NOT EXCEED THE WORKING LOAD LIMIT

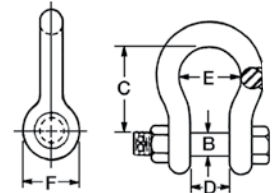

FITTINGS

Trade Size	Cat. No.	UPC No.	WLL (Short Tons)	B Dim.	C Dim.	D Dim.	E Dim.	F Dim.	(C) Tolerance (+/-)	(D) Tolerance (+/-)	Weight Each
1/4 in	5390435	020418193156	1/2 T	5/16 in	1-1/8 in	15/32 in	25/32 in	11/16 in	1/16 in	1/8 in	0.10 lb
3/8 in	5390635	020418193170	1 T	7/16 in	1-7/16 in	21/32 in	31/32 in	15/16 in	1/8 in	1/8 in	0.30 lb
1/2 in	5390835	020418075520	2 T	5/8 in	1-15/16 in	13/16 in	1-1/4 in	1-1/4 in	1/8 in	1/8 in	0.70 lb
5/8 in	5391035	020418075544	3-1/4 T	3/4 in	2-7/16 in	1-1/16 in	1-9/16 in	1-7/16 in	1/8 in	1/8 in	1.30 lb
3/4 in	5391235	020418075568	4-3/4 T	7/8 in	2-13/16 in	1-1/4 in	1-13/16 in	1-3/4 in	1/4 in	1/8 in	2.00 lb
7/8 in	5391435	020418075582	6-1/2 T	1 in	3-1/8 in	1-7/16 in	2-1/16 in	2 in	1/4 in	1/8 in	3.30 lb
1 in	5391635	020418075605	8-1/2 T	1-1/8 in	3-3/4 in	1-11/16 in	2-1/2 in	2-3/8 in	1/4 in	1/8 in	5.00 lb
1-1/8 in	5391835	020418075629	9-1/2 T	1-1/4 in	4-1/4 in	1-13/16 in	2-15/16 in	2-5/8 in	1/4 in	1/8 in	7.10 lb
1-1/4 in	5392035	020418075643	12 T	1-3/8 in	4-1/2 in	2 in	3-1/4 in	3 in	1/4 in	1/8 in	10.00 lb
1-3/8 in	5392235	020418075667	13-1/2 T	1-1/2 in	5-1/4 in	2-1/4 in	3-1/2 in	3-1/4 in	1/4 in	3/16 in	13.00 lb
1-1/2 in	5392435	020418075681	17 T	1-5/8 in	5-3/4 in	2-3/8 in	3-7/8 in	3-1/2 in	1/4 in	3/16 in	16.00 lb
1-3/4 in	5392835	020418075735	25 T	2 in	7 in	2-7/8 in	4-3/4 in	4 in	1/4 in	3/16 in	28.50 lb
2 in	5393235	020418075766	35 T	2-1/4 in	7-3/4 in	3-1/4 in	5-3/4 in	4-7/8 in	1/2 in	3/16 in	40.00 lb
2-1/2 in	5394035	020418075797	55 T	2-3/4 in	10-1/2 in	4-1/8 in	7-1/4 in	5-1/2 in	1/2 in	1/4 in	90.00 lb

Alloy Bolt Type Anchor Shackles, Galvanized, A-999-G



- Shackle Bodies Are Drop-Forged Alloy Steel
- Galvanized to Meet ASTM A-153 Specifications
- A-999-G Shackles Meet the Design Requirements of Federal Specification RR-C-271, Type IVA Grade B, Class 3
- Working Load Limit, Size, Manufacture Name, Date Code, "CE" Mark, and USA Permanently Marked on Each Shackle
- Statistically Tested for Impact Resistance, Tensile Strength, Hardness, Ductility and Fatigue
- 999 Series Shackles Meet or Exceed All Manufacturing Requirements of the ASME B30.26 "Rigging Hardware". These Include the Material Ductility Requirement (Section 26-1.1.2), the Design Factor Requirement (Section 26.1.2), the Identification Requirement (Section 26-1.5.1), and the Effective Temperature Range (Section 26-1.6.1)
- The Shackles Can Be Proof Tested in Accordance with Section 26-1.4 upon request
- Certification Available Upon Request
- 5 to 1 Design Factor
- Pins and Bolts Are Heat-Treated, Made of Alloy Steel and Painted Orange
- DO NOT EXCEED THE WORKING LOAD LIMIT

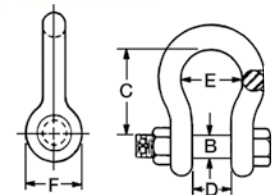

Trade Size	Cat. No.	UPC No.	WLL (Metric Tons)	B Dim.	C Dim.	D Dim.	E Dim.	F Dim.	(C) Tolerance (+/-)	(D) Tolerance (+/-)	Weight Each
3/8 in	5390695	020418267338	2 t	7/16 in	1-7/16 in	21/32 in	31/32 in	15/16 in	1/8 in	1/8 in	0.30 lb
1/2 in	5390895	020418182198	3-1/3 t	5/8 in	1-15/16 in	13/16 in	1-1/4 in	1-1/4 in	1/8 in	1/8 in	0.88 lb
5/8 in	5391095	020418267345	5 t	3/4 in	2-3/8 in	1-1/16 in	1-11/16 in	1-1/2 in	1/8 in	1/8 in	1.40 lb
3/4 in	5391295	020418182105	7 t	7/8 in	2-13/16 in	1-1/4 in	1-13/16 in	1-3/4 in	1/4 in	1/8 in	2.66 lb
7/8 in	5391495	020418267352	9-1/2 t	1 in	3-5/16 in	1-7/16 in	2-9/32 in	2-3/32 in	1/4 in	1/8 in	3.60 lb
1 in	5391695	020418182112	12-1/2 t	1-1/8 in	3-3/4 in	1-11/16 in	2-1/2 in	2-3/8 in	1/4 in	1/8 in	6.12 lb
1-1/4 in	5392095	020418267369	18 t	1-3/8 in	4-1/2 in	2 in	3-1/4 in	3 in	1/4 in	1/8 in	10.00 lb
1-1/2 in	5392495	020418267383	30 t	1-5/8 in	5-3/4 in	2-3/8 in	3-7/8 in	3-5/8 in	1/4 in	3/16 in	18.90 lb

FITTINGS



Carbon Screw Pin Anchor Shackles, Self-Colored, C-419-S

- Shackle Bodies Are Drop-Forged Carbon Steel
- Self Colored (Painted Blue)
- C-419-S Shackles Meet the Design Requirements of Federal Specification RR-C-271, Type IVA, Grade A, Class 2
- Working Load Limit, Size, Manufacture Name, Date Code and USA Permanently Marked on Each Shackle
- Statistically Tested for Impact Resistance, Tensile Strength, Hardness, Ductility and Fatigue
- 419 Series Shackles Meet or Exceed All Manufacturing Requirements of the ASME B30.26 "Rigging Hardware". These Include the Material Ductility Requirement (Section 26-1.1.2), the Design Factor Requirement (Section 26.1.2), the Identification Requirement (Section 26-1.5.1), and the Effective Temperature Range (Section 26-1.6.1).
- The Shackles Can Be Proof Tested in Accordance with Section 26-1.4 upon request
- Certification Available Upon Request
- 6 to 1 Design Factor
- Pins and Bolts Are Heat-Treated and Made of Alloy Steel
- DO NOT EXCEED THE WORKING LOAD LIMIT

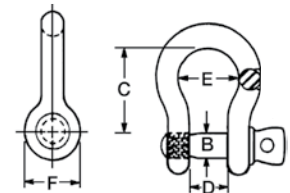

FITTINGS

Trade Size	Cat. No.	UPC No.	WLL (Short Tons)	B Dim.	C Dim.	D Dim.	E Dim.	F Dim.	(C) Tolerance (+/-)	(D) Tolerance (+/-)	Weight Each
1/4 in	5410405	020418076145	1/2 T	5/16 in	1-1/8 in	15/32 in	25/32 in	11/16 in	1/16 in	1/8 in	0.10 lb
5/16 in	5410505	020418076176	3/4 T	3/8 in	1-1/4 in	17/32 in	27/32 in	3/4 in	1/16 in	1/8 in	0.20 lb
3/8 in	5410605	020418076206	1 T	7/16 in	1-7/16 in	21/32 in	31/32 in	15/16 in	1/8 in	1/8 in	0.30 lb
7/16 in	5410705	020418076237	1-1/2 T	1/2 in	1-3/4 in	23/32 in	1-5/32 in	1-1/8 in	1/8 in	1/8 in	0.52 lb
1/2 in	5410805	020418076268	2 T	5/8 in	1-15/16 in	13/16 in	1-1/4 in	1-1/4 in	1/8 in	1/8 in	0.80 lb
5/8 in	5411005	020418076282	3-1/4 T	3/4 in	2-7/16 in	1-1/16 in	1-9/16 in	1-7/16 in	1/8 in	1/8 in	1.50 lb
3/4 in	5411205	020418076305	4-3/4 T	7/8 in	2-13/16 in	1-1/4 in	1-13/16 in	1-3/4 in	1/4 in	1/8 in	2.00 lb
7/8 in	5411405	020418076329	6-1/2 T	1 in	3-1/8 in	1-7/16 in	2-1/16 in	2 in	1/4 in	1/8 in	3.20 lb
1 in	5411605	020418076343	8-1/2 T	1-1/8 in	3-3/4 in	1-11/16 in	2-1/2 in	2-3/8 in	1/4 in	1/8 in	5.00 lb
1-1/8 in	5411805	020418076367	9-1/2 T	1-1/4 in	4-1/4 in	1-13/16 in	2-15/16 in	2-5/8 in	1/4 in	1/8 in	7.00 lb
1-1/4 in	5412005	020418076381	12 T	1-3/8 in	4-1/2 in	2 in	3-1/4 in	3 in	1/4 in	1/8 in	10.00 lb
1-3/8 in	5412205	020418076404	13-1/2 T	1-1/2 in	5-1/4 in	2-1/4 in	3-1/2 in	3-1/4 in	1/4 in	3/16 in	13.00 lb
1-1/2 in	5412405	020418076428	17 T	1-5/8 in	5-3/4 in	2-3/8 in	3-7/8 in	3-1/2 in	1/4 in	3/16 in	16.00 lb
1-3/4 in	5412805	020418076459	25 T	2 in	7 in	2-7/8 in	4-3/4 in	4 in	1/4 in	3/16 in	26.00 lb
2 in	5413205	020418076473	35 T	2-1/4 in	7-3/4 in	3-1/4 in	5-3/4 in	4-7/8 in	1/2 in	3/16 in	41.00 lb



Carbon Screw Pin Anchor Shackles, Galvanized, C-419-G

- Shackle Bodies Are Drop-Forged Carbon Steel
- Galvanized to Meet ASTM A-153 Specifications
- C-419-G Shackles Meet the Design Requirements of Federal Specification RR-C-271, Type IVA, Grade A, Class 2
- Working Load Limit, Size, Manufacture Name, Date Code and USA Permanently Marked on Each Shackle
- Statistically Tested for Impact Resistance, Tensile Strength, Hardness, Ductility and Fatigue
- 419 Series Shackles Meet or Exceed All Manufacturing Requirements of the ASME B30.26 "Rigging Hardware". These Include the Material Ductility Requirement (Section 26-1.1.2), the Design Factor Requirement (Section 26.1.2), the Identification Requirement (Section 26-1.5.1), and the Effective Temperature Range (Section 26-1.6.1).
- The Shackles Can Be Proof Tested in Accordance with Section 26-1.4 upon request
- Certification Available Upon Request
- 6 to 1 Design Factor on Shackles 1/4" to 2"
- 5 to 1 Design Factor on 2-1/2"
- Pins and Bolts Are Heat-Treated and Made of Alloy Steel
- DO NOT EXCEED THE WORKING LOAD LIMIT

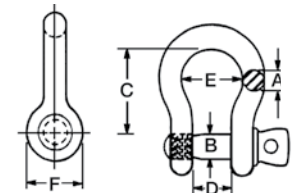

FITTINGS

Trade Size	Cat. No.	UPC No.	WLL (Short Tons)	B Dim.	C Dim.	D Dim.	E Dim.	F Dim.	(C) Tolerance (+/-)	(D) Tolerance (+/-)	Weight Each
1/4 in	5410435	020418076169	1/2 T	5/16 in	1-1/8 in	15/32 in	25/32 in	11/16 in	1/16 in	1/8 in	0.10 lb
5/16 in	5410535	020418076190	3/4 T	3/8 in	1-1/4 in	17/32 in	27/32 in	3/4 in	1/16 in	1/8 in	0.20 lb
3/8 in	5410635	020418076220	1 T	7/16 in	1-7/16 in	21/32 in	31/32 in	15/16 in	1/8 in	1/8 in	0.30 lb
7/16 in	5410735	020418076251	1-1/2 T	1/2 in	1-3/4 in	23/32 in	1-5/32 in	1-1/8 in	1/8 in	1/8 in	0.52 lb
1/2 in	5410835	020418076275	2 T	5/8 in	1-15/16 in	13/16 in	1-1/4 in	1-1/4 in	1/8 in	1/8 in	0.80 lb
5/8 in	5411035	020418076299	3-1/4 T	3/4 in	2-7/16 in	1-1/16 in	1-9/16 in	1-7/16 in	1/8 in	1/8 in	1.06 lb
3/4 in	5411235	020418076312	4-3/4 T	7/8 in	2-13/16 in	1-1/4 in	1-13/16 in	1-3/4 in	1/4 in	1/8 in	2.15 lb
7/8 in	5411435	020418076336	6-1/2 T	1 in	3-1/8 in	1-7/16 in	2-1/16 in	2 in	1/4 in	1/8 in	3.20 lb
1 in	5411635	020418076350	8-1/2 T	1-1/8 in	3-3/4 in	1-11/16 in	2-1/2 in	2-3/8 in	1/4 in	1/8 in	5.00 lb
1-1/8 in	5411835	020418076374	9-1/2 T	1-1/4 in	4-1/4 in	1-13/16 in	2-15/16 in	2-5/8 in	1/4 in	1/8 in	7.00 lb
1-1/4 in	5412035	020418076398	12 T	1-3/8 in	4-1/2 in	2 in	3-1/4 in	3 in	1/4 in	1/8 in	10.00 lb
1-3/8 in	5412235	020418076411	13-1/2 T	1-1/2 in	5-1/4 in	2-1/4 in	3-1/2 in	3-1/4 in	1/4 in	3/16 in	13.00 lb
1-1/2 in	5412435	020418076435	17 T	1-5/8 in	5-3/4 in	2-3/8 in	3-7/8 in	3-1/2 in	1/4 in	3/16 in	16.00 lb
1-3/4 in	5412835	020418076466	25 T	2 in	7 in	2-7/8 in	4-3/4 in	4 in	1/4 in	3/16 in	26.00 lb
2 in	5413235	020418076480	35 T	2-1/4 in	7-3/4 in	3-1/4 in	5-3/4 in	4-7/8 in	1/2 in	3/16 in	40.00 lb
2-1/2 in	5414035	020418076527	55 T	2-3/4 in	10-1/2 in	4-1/8 in	7-1/4 in	5-1/2 in	1/2 in	1/4 in	90.00 lb



Alloy Screw Pin Anchor Shackles, Galvanized, A-419-G

- Shackle Bodies Are Drop-Forged Alloy Steel
- Galvanized to Meet ASTM A-153 Specifications
- A-419-G Shackles Meet the Design Requirements of Federal Specification RR-C-271, Type IVA, Grade B, Class 2
- Working Load Limit, Size, Manufacture Name, Date Code, "CE" Mark, and USA Permanently Marked on Each Shackle
- Statistically Tested for Impact Resistance, Tensile Strength, Hardness, Ductility and Fatigue
- 419 Series Shackles Meet or Exceed All Manufacturing Requirements of the ASME B30.26 "Rigging Hardware". These Include the Material Ductility Requirement (Section 26-1.1.2), the Design Factor Requirement (Section 26.1.2), the Identification Requirement (Section 26-1.5.1), and the Effective Temperature Range (Section 26-1.6.1).
- The Shackles Can Be Proof Tested in Accordance with Section 26-1.4 upon request
- Certification Available Upon Request
- 5 to 1 Design Factor
- Pins and Bolts Are Heat-Treated and Made of Alloy Steel and Painted Orange
- DO NOT EXCEED THE WORKING LOAD LIMIT

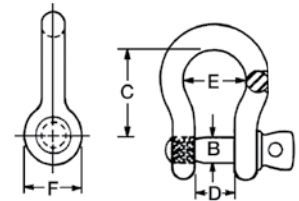

FITTINGS

Trade Size	Cat. No.	UPC No.	B Dim.	C Dim.	D Dim.	E Dim.	F Dim.	C Tolerance (+/-)	D Tolerance (+/-)	WLL Metric Ton	Weight Each
3/8 in	5410695	020418182136	7/16 in	1-7/16 in	21/32 in	31/32 in	15/16 in	1/8 in	1/8 in	2 t	0.31 lb
1/2 in	T5410895	020418182143	5/8 in	1-15/16 in	13/16 in	1-1/4 in	1-1/4 in	1/8 in	1/8 in	3-1/3 t	0.70 lb
5/8 in	5411095	020418267420	3/4 in	2-3/8 in	1-1/16 in	1-11/16 in	1-1/2 in	1/8 in	1/8 in	5 t	1.40 lb
3/4 in	5411295	020418182150	7/8 in	2-13/16 in	1-1/4 in	1-13/16 in	1-3/4 in	1/4 in	1/8 in	7 t	2.00 lb
7/8 in	5411495	020418267437	1 in	3-5/16 in	1-7/16 in	2-9/32 in	2-3/32 in	1/4 in	1/8 in	9-1/2 t	3.60 lb
1 in	5411695	020418182167	1-1/8 in	3-3/4 in	1-11/16 in	2-1/2 in	2-3/8 in	1/4 in	1/8 in	12-1/2 t	5.70 lb
1-1/4 in	5412095	020418182174	1-3/8 in	4-1/2 in	2 in	3-1/4 in	3 in	1/4 in	1/8 in	18 t	10.50 lb
1-3/8 in	5412295	020418267444	1-1/2 in	5-1/4 in	2-1/4 in	3-5/8 in	3-5/16 in	1/4 in	3/16 in	21 t	13.30 lb
1-1/2 in	5412495	020418267451	1-5/8 in	5-3/4 in	2-3/8 in	3-7/8 in	3-5/8 in	1/4 in	3/16 in	30 t	18.90 lb

Hoist Hooks

Campbell hoist hooks are all drop-forged and heat treated. All hooks are drilled for latch assembly.

(1st letter indicates material, number is type, last letter indicates finish)

- Eye Hoist - Unlatched C-1010-S, A-1010-O
- Eye Hoist - Latched C-1015-S, C-1015-G, A-1015-O
- Swivel Hoist - Unlatched C-1013-S, A-1013-O
- Swivel Hoist - Latched C-1014-S, A-1014-O



SWIVEL HOIST HOOK



EYE HOIST HOOK

READ AND UNDERSTAND THESE WARNINGS AND INSTRUCTIONS BEFORE USING HOIST HOOKS.

IMPORTANT: Instructions For Use

1. For hooks with latches, the latch is only designed to retain slings and rigging attachments. The latch must not support the load.
2. Swivel hoist hooks are not designed to swivel under load.
3. Do not exceed working load limit (WLL). See table right.

Working Load Limits Hooks

Size	Carbon Steel WLL		Alloy WLL	
	Ton	kg	Ton	kg
2/22	3/4	680	1	907
3/23	1	907	1 1/2	1361
4/24	1-1/2	1361	2	1814
5/25	2	1814	3	2722
6/26	2-1/2	2268	4	3629
7/27	3	2722	5	4082
9/29	5	4536	7	6350
11/31	7-1/2	6804	11	9979
12/32	10	9072	15	13608
34	-	-	22	19958

WARNING

- Failure to follow the instructions for use and these warnings may cause death or serious injury.
- Use hoist hooks only as indicated.
- Never point load a hook.
- Do not use hooks for lifting personnel.
- Hooks must always be inspected for wear, distortion and damage before use. If worn, distorted or damaged, discard and replace.
- Do not weld on hooks. If a hook is exposed to weld spatter, discard that hook.
- Always stand clear of loads being lifted.



Swivel Hoist Hooks - Latched, C-1014-S, A-1014-0

- Drop Forged Carbon Steel or Alloy and Heat Treated
- Carbon Steel Hooks Are Painted Blue; Alloy Hooks Are Painted Orange
- Design Factor: 5 to 1
- All Hooks Are Drilled for Integrated Latch Kits
- The Latch Is Only Designed to Retain Slings and Rigging Attachments. The Latch Must Not Support the Load.
- Swivel Hoist Hooks ARE NOT Designed to Swivel Under Load.
- DO NOT EXCEED THE WORKING LOAD LIMIT

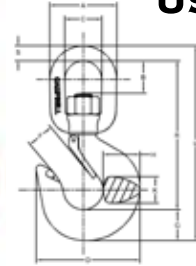

FITTINGS

Trade Size	Cat. No.	UPC No.	Material	Finish	WLL Short Tons	Latch Marking	Replacement Latch No.	Weight Each
2	3942205PL	020418306419	Carbon Steel	Painted	3/4 T	PL-3	7506295PL	1.00 lb
2	3952215PL	020418306402	Alloy Steel	Painted	1 T	PL-3	7506295PL	0.900 lb
4	3952415PL	020418306365	Alloy Steel	Painted	2 T	PL-4	7506495PL	2.06 lb
5	3952515PL	020418306310	Alloy Steel	Painted	3 T	PL-4	7506495PL	5.79 lb
7	3952715PL	020418306280	Alloy Steel	Painted	5 T	PL-5	7506695PL	4.500 lb
9	3952915PL	020418306273	Alloy Steel	Painted	7 T	PL-7	7506895PL	10.000 lb
11	3953115PL	020418295614	Alloy Steel	Painted	11 T	PL-8	7507095PL	19.60 lb
12	3953215PL	020418295652	Alloy Steel	Painted	15 T	PL-9	7507295PL	27.3 lb

Trade Size	Cat. No.	A Dim.	B Dim.	C Dim.	D Dim.	E Dim.	F Dim.	G Dim.	H Dim.	K Dim.	L Dim.	R Dim.	S Dim.
2	3942205PL	2 in	1 in	1-1/4 in	3-5/32 in	1-9/32 in	31/32 in	3/4 in	29/32 in	21/32 in	5-27/32 in	4-13/16 in	3/8 in
2	3952215PL	2 in	1 in	1-1/4 in	3-5/32 in	1-9/32 in	31/32 in	3/4 in	29/32 in	21/32 in	5-27/32 in	4-13/16 in	3/8 in
4	3952415PL	2-1/2 in	1-1/4 in	1-1/2 in	3-13/16 in	1-7/16 in	1-5/32 in	1-1/16 in	1-1/4 in	29/32 in	7-17/32 in	6 in	1/2 in
5	3952515PL	3 in	1-5/8 in	1-3/4 in	4-1/8 in	1-13/32 in	1-5/32 in	1-1/4 in	1-1/2 in	1 in	8-1/4 in	6-7/16 in	5/8 in
7	3952715PL	3-1/2 in	1-3/4 in	2 in	5-1/8 in	1-11/16 in	1-11/16 in	1-15/32 in	1-7/8 in	1-3/8 in	9-5/8 in	8-3/32 in	3/4 in
9	3952915PL	4-1/2 in	2-1/4 in	2-1/2 in	6-3/16 in	2-1/16 in	1-21/32 in	1-27/32 in	2-7/32 in	1-5/8 in	12-21/32 in	9-5/8 in	1 in
11	3953115PL	5-5/8 in	3-1/8 in	3-1/8 in	7-9/16 in	2-17/32 in	2-1/32 in	2-9/32 in	2-23/32 in	2 in	15-7/8 in	12-11/32 in	1-1/4 in
12	3953215PL	5-5/8 in	2-3/4 in	3-1/8 in	8-3/4 in	2-3/4 in	2-9/32 in	2-19/32 in	3-1/8 in	2-1/4 in	16-13/32 in	12-17/32 in	1-1/4 in

Eye Hoist Hooks - Latched, C-1015-S, C-1015-G, A-1015-O

- Drop Forged Carbon Steel or Alloy and Heat Treated
- Carbon Steel Hooks Painted Blue or Galvanized to ASTM A-153 Specifications; Alloy Hooks Are Painted Orange
- 5 to 1 Design Factor
- All Hooks Are Drilled for Integrated Latch Kits
- The Latch Is Only Designed to Retain Slings and Rigging Attachments. The Latch Must Not Support the Load.
- DO NOT EXCEED THE WORKING LOAD LIMIT

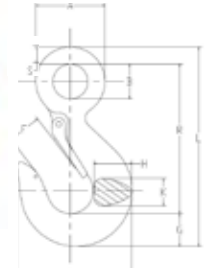

Trade Size	Cat. No.	UPC No.	Material	Finish	WLL (Short Tons)	Latch Marking	Replacement Latch No.	Weight Each
22	3914205PL	020418316739	Carbon Steel	Painted	3/4 T	PL-3	7506295PL	0.650 lb
22	3914235PL	020418316746	Carbon Steel	Galvanized	3/4 T	PL-3	7506295PL	0.650 lb
23	3914305PL	020418316760	Carbon Steel	Painted	1 T	PL-3	7506295PL	0.800 lb
24	3914405PL	020418316791	Carbon Steel	Painted	1-1/2 T	PL-4	7506495PL	1.78 lb
24	3914435PL	020418316807	Carbon Steel	Galvanized	1-1/2 T	PL-4	7506495PL	1.80 lb
27	3914705PL	020418319037	Carbon Steel	Painted	3 T	PL-5	7506695PL	4.41 lb
29	3914905PL	020418319075	Carbon Steel	Painted	5 T	PL-7	7506895PL	8.20 lb
22	3924215PL	020418316753	Alloy Steel	Painted	1 T	PL-3	7506295PL	0.650 lb
23	3924315PL	020418316777	Alloy Steel	Painted	1-1/2 T	PL-3	7506295PL	0.800 lb
24	3924415PL	020418316814	Alloy Steel	Painted	2 T	PL-4	7506495PL	1.050 lb
25	3924515PL	020418319013	Alloy Steel	Painted	3 T	PL-4	7506495PL	2.35 lb
27	3924715PL	020418319051	Alloy Steel	Painted	5 T	PL-5	7506695PL	4.000 lb
29	3924915PL	020418319099	Alloy Steel	Painted	7 T	PL-7	7506895PL	8.000 lb
31	3925115PL	020418319129	Alloy Steel	Painted	11 T	PL-8	7507095PL	13.000 lb

Trade Size	Cat. No.	A Dim.	B Dim.	D Dim.	E Dim.	F Dim.	G Dim.	H Dim.	K Dim.	L Dim.	R Dim.	S Dim.
22	3914205PL	1-19/32 in	27/32 in	3 in	1-1/4 in	15/16 in	3/4 in	29/32 in	21/32 in	5-3/16 in	4-1/16 in	3/8 in
22	3914235PL	1-19/32 in	27/32 in	3 in	1-1/4 in	15/16 in	3/4 in	29/32 in	21/32 in	5-3/16 in	4-1/16 in	3/8 in
23	3914305PL	1-25/32 in	15/16 in	3-19/32 in	1-5/16 in	1-1/16 in	29/32 in	1-1/8 in	25/32 in	5-19/32 in	4-1/4 in	7/16 in
24	3914405PL	2-1/4 in	1-1/8 in	3-13/16 in	1-13/32 in	1-5/32 in	1-1/16 in	1-1/4 in	29/32 in	6-15/32 in	4-27/32 in	17/32 in
24	3914435PL	2-1/4 in	1-1/8 in	3-13/16 in	1-13/32 in	1-5/32 in	1-1/16 in	1-1/4 in	29/32 in	6-15/32 in	4-27/32 in	17/32 in
27	3914705PL	3 in	1-9/16 in	5 in	1-11/16 in	1-3/8 in	1-15/32 in	1-7/8 in	1-13/32 in	8-7/16 in	6-7/32 in	23/32 in
29	3914905PL	3-13/16 in	2 in	6-3/16 in	2-1/16 in	1-21/32 in	1-27/32 in	2-7/32 in	1-21/32 in	10-1/2 in	7-3/4 in	29/32 in
22	3924215PL	1-19/32 in	27/32 in	3 in	1-1/4 in	15/16 in	3/4 in	29/32 in	21/32 in	5-3/16 in	4-1/16 in	3/8 in
23	3924315PL	1-25/32 in	15/16 in	3-19/32 in	1-5/16 in	1-1/16 in	29/32 in	1-1/8 in	25/32 in	5-19/32 in	4-1/4 in	7/16 in
24	3924415PL	2-1/4 in	1-1/8 in	3-13/16 in	1-13/32 in	1-5/32 in	1-1/16 in	1-1/4 in	29/32 in	6-15/32 in	4-27/32 in	17/32 in
25	3924515PL	2-7/16 in	1-9/32 in	4-1/4 in	1-15/32 in	1-7/32 in	1-1/4 in	1-1/2 in	1 in	6-31/32 in	5-5/32 in	19/32 in
27	3924715PL	3 in	1-9/16 in	5 in	1-11/16 in	1-3/8 in	1-15/32 in	1-7/8 in	1-13/32 in	8-7/16 in	6-7/32 in	23/32 in
29	3924915PL	3-13/16 in	2 in	6-3/16 in	2-1/16 in	1-21/32 in	1-27/32 in	2-7/32 in	1-21/32 in	10-1/2 in	7-3/4 in	29/32 in
31	3925115PL	4-11/16 in	2-7/16 in	7-9/16 in	2-17/32 in	2-1/32 in	2-9/32 in	2-23/32 in	2 in	12-13/16 in	9-7/16 in	1-1/8 in

FITTINGS



Sorting Hooks, A-479-0

- Drop Forged Heat-Treated Alloy Steel
- 5 to 1 Design Factor
- Available with Handle for Safety and Control
- Made in the USA
- Handle is Not to Be Used for Supporting Load

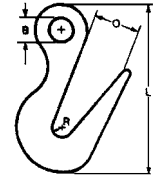

Cat. No.	UPC No.	Finish	B Dim.	L Dim.	O Dim.	R Dim.	Working LL - Bottom	WLL- Tip	Weight Each
3899500	020418070723	Painted	1-3/8 in	9-3/4 in	2-13/16 in	5/8 in	7-1/2 T	2 T	6.00 lb
3899501	020418193040	Painted	1-3/8 in	9-3/4 in	2-13/16 in	5/8 in	7-1/2 T	2 T	6.25 lb

Eye Grab Hooks, Grade 43, (Import)

- Forged Steel
- Grade 43
- Grab Hooks Are Designed to Grab a Chain Link and Hold it in Place
- DO NOT EXCEED THE WORKING LOAD LIMIT



Trade Size	Cat. No.	UPC No.	Hook Style	Finish	Working Load Limit	Weight Each (lb)	Shelf Pack	Case Pack
1/4 in	T9001424	020418222139	Eye	Zinc Plated	2600 lb	0.34 lb	10	100
5/16 in	T9001524	020418222146	Eye	Zinc Plated	3900 lb	0.55 lb	10	50
3/8 in	T9001624	020418222153	Eye	Zinc Plated	5400 lb	0.90 lb	10	50
1/2 in	T9001824	020418222122	Eye	Zinc Plated	9200 lb	1.80 lb	5	20

Eye Slip Hooks, Grade 43, (Import)

- Forged Steel
- UPC Tagged
- Slip Hooks Are Designed to Allow Chain to Slip Through the Hook
- DO NOT EXCEED THE WORKING LOAD LIMIT



Trade Size	Cat. No.	UPC No.	Hook Style	Finish	Working Load Limit	Weight Each	Shelf Pack	Case Pack
1/4 in	T9101424	020418222177	Eye	Zinc Plated	2600 lb	0.40 lb	10	100
5/16 in	T9101524	020418222184	Eye	Zinc Plated	3900 lb	0.70 lb	10	50
3/8 in	T9101624	020418222191	Eye	Zinc Plated	5400 lb	1.00 lb	10	50
1/2 in	T9101824	020418222160	Eye	Zinc Plated	9200 lb	2.60 lb	5	20

Clevis Grab Hooks, Grade 43, (Import)

- Forged Steel
- Grade 43
- Grab Hooks Are Designed to Grab a Chain Link and Hold it in Place
- Hooks are Sized by the Material Diameter of the Chain That They Engage. Make Sure Hook Size and Chain Diameter are Compatible Before Attaching to Load
- DO NOT EXCEED THE WORKING LOAD LIMIT



Trade Size	Cat. No.	UPC No.	For Chain Size	Hook Style	Finish	Working Load Limit	Weight Each	Shelf Pack	Case Pack
1/4 in	T9501424	020418192678	1/4 in	Clevis	Zinc Plated	2600 lb	0.43 lb	10	100
5/16 in	T9501524	020418192685	5/16 in	Clevis	Zinc Plated	3900 lb	0.73 lb	10	50
3/8 in	T9501624	020418192692	3/8 in	Clevis	Zinc Plated	5400 lb	1.11 lb	10	50
1/2 in	T9501824	020418220661	1/2 in	Clevis	Zinc Plated	9200 lb	1.85 lb	5	20

Clevis Grab Hooks, Grade 70, (Import)

- Forged Steel
- Transport Grade
- Grab Hooks Are Designed to Grab a Chain Link and Hold it in Place
- Hooks are Sized by the Material Diameter of the Chain That They Engage. Make Sure Hook Size and Chain Diameter are Compatible Before Attaching to Load
- DO NOT EXCEED THE WORKING LOAD LIMIT



Trade Size	Cat. No.	UPC No.	For Chain Size	Hook Style	Finish	Working Load Limit	Weight Each	Shelf Pack	Case Pack
1/4 in	T9503315	020418289316	1/4 in	Clevis	Yellow Chromate	3150 lb	0.43 lb	10	100
5/16 in	T9503415	020418201974	5/16 in	Clevis	Yellow Chromate	4700 lb	0.71 lb	10	50
3/8 in	T9503515	020418201981	3/8 in	Clevis	Yellow Chromate	6600 lb	1.18 lb	5	25

Clevis Grab Hooks, A-473-0

- Material is Drop-Forged Carbon Steel (Grade 30 & 43) or Heat-Treated Alloy Steel
- Alloy Hooks Are Painted Orange and Stamped "Alloy"; 3.5 to 1 Design Factor
- Alloy Hook Sizes 1/4" to 3/8" are Individually Bagged and Unassembled
- Grab Hooks Are Designed to Grab a Chain Link and Hold it in Place
- Hooks are Sized by the Material Diameter of the Chain That They Engage. Make Sure Hook Size and Chain Diameter are Compatible Before Attaching to Load
- DO NOT EXCEED THE WORKING LOAD LIMIT

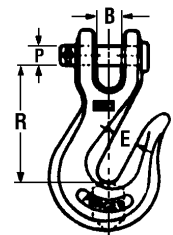

Trade Size	Cat. No.	UPC No.	Finish	B Dim.	E Dim.	P Dim.	R Dim.	Working Load Limit	Weight Each
1/4 in	4503315	020418074103	Painted	3/8 in	11/32 in	5/16 in	1-23/32 in	4100 lb	0.38 lb
5/16 in	4503415	020418074110	Painted	15/32 in	7/16 in	3/8 in	1-31/32 in	5100 lb	0.60 lb
3/8 in	4503515	020418074127	Painted	17/32 in	1/2 in	7/16 in	2-1/4 in	7100 lb	0.92 lb
1/2 in	4503715	020418074141	Painted	21/32 in	21/32 in	9/16 in	3-1/64 in	12000 lb	2.00 lb
5/8 in	4503815	020418074158	Painted	13/16 in	25/32 in	3/4 in	3-25/32 in	18100 lb	3.90 lb
3/4 in	4503915	020418074165	Painted	15/16 in	15/16 in	13/16 in	4-25/32 in	28300 lb	6.34 lb



Clevis Slip Hooks, Grade 70, (Import)

- Forged Steel
- Transport Grade
- Slip Hooks Are Designed to Allow Chain to Slip Through the Hook
- Hooks are Sized by the Material Diameter of the Chain That They Engage. Be Sure the Hook Size/Chain Diameter are Compatible Before Attaching



Trade Size	Cat. No.	UPC No.	For Chain Size	Hook Style	Finish	Working Load Limit	Weight Each	Shelf Pack	Case Pack
1/4 in	T9504315	020418289323	1/4 in	Clevis w/ Latch	Yellow Chromate	3150 lb	0.65 lb	5	50
5/16 in	T9504415	020418289330	5/16 in	Clevis w/ Latch	Yellow Chromate	4700 lb	0.85 lb	5	50
3/8 in	T9504515	020418289347	3/8 in	Clevis w/ Latch	Yellow Chromate	6600 lb	1.41 lb	5	30

Clevis Slip Hooks, A-476-0

- Material is Heat-Treated Alloy Steel
- Alloy Hooks Are Stamped "A"
- 1/4" to 3/8" Hooks Have Drilled Hole for Latch Kit
- Design Factor: 3.5 to 1
- Slip Hooks Are Designed to Allow Chain to Slip Through the Hook
- Hooks are Sized by the Material Diameter of the Chain That They Engage. Be Sure the Hook Size/Chain Diameter are Compatible Before Attaching
- DO NOT EXCEED THE WORKING LOAD LIMIT

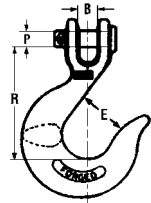

Trade Size	Cat. No.	UPC No.	Material	Finish	B Dim.	E Dim.	P Dim.	R Dim.	Working Load Limit	Weight Each
5/16 in	4403415	020418073823	Alloy Steel	Painted	7/16 in	1-1/16 in	3/8 in	3 in	5100 lb	0.90 lb
3/8 in	4403515	020418073830	Alloy Steel	Painted	1/2 in	1-1/4 in	7/16 in	3-13/32 in	7100 lb	1.44 lb
1/2 in	4403715	020418073854	Alloy Steel	Painted	5/8 in	1-3/4 in	9/16 in	4-3/32 in	13000 lb	3.12 lb

Clevis Slip Hooks, Grade 43, (Import)

- Forged Steel
- Grade 43
- Slip Hooks Are Designed to Allow Chain to Slip Through the Hook
- Hooks are Sized by the Material Diameter of the Chain That They Engage. Be Sure the Hook Size/Chain Diameter are Compatible Before Attaching



Clevis Slip Hook

Clevis Slip Hook with Latch

Trade Size	Cat. No.	UPC No.	For Chain Size	Hook Style	Finish	Working Load Limit	Weight Each	Shelf Pack	Case Pack
1/4 in	T9401424	020418192647	1/4 in	Clevis	Zinc Plated	2600 lb	0.55 lb	5	100
1/4 in	T9700424	020418192081	1/4 in	Clevis w/ Latch	Zinc Plated	2600 lb	0.65 lb	5	50
5/16 in	T9401524	020418192654	5/16 in	Clevis	Zinc Plated	3900 lb	0.79 lb	5	50
5/16 in	T9700524	020418192098	5/16 in	Clevis w/ Latch	Zinc Plated	3900 lb	0.85 lb	5	50
3/8 in	T9401624	020418192661	3/8 in	Clevis	Zinc Plated	5400 lb	1.41 lb	5	50
3/8 in	T9700624	020418192104	3/8 in	Clevis w/ Latch	Zinc Plated	5400 lb	1.41 lb	5	30
1/2 in	T9401824	020418220654	1/2 in	Clevis	Zinc Plated	9200 lb	2.87 lb	5	15
1/2 in	T9700824	020418220647	1/2 in	Clevis w/ Latch	Zinc Plated	9200 lb	2.88 lb	5	15

Latch Kits for Non-Integrated Hooks

Campbell offers latches already assembled to the hook as well as kits for field installation.

- Clapper latches are zinc-plated
- Spring spacer adapts latch to hooks with narrow cam
- Bolt and nut permit fast, easy installation



916-G LATCH KIT
FOR CAMPBELL HOOK

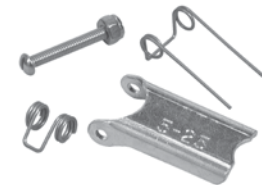

916-U UNIVERSAL LATCH KIT
FOR ALL MAJOR HOOK BRANDS

READ AND UNDERSTAND THESE WARNINGS AND INSTRUCTIONS BEFORE USING HOOK AND LATCH.

IMPORTANT: Instructions For Use

1. Always inspect the hook and latch before using.
2. Always make sure the spring forces the latch against the point of the hook.
3. Check the load before lifting to make sure the hook (not the latch) is supporting the load.
4. To assemble latches on hooks, follow instructions supplied with kit.

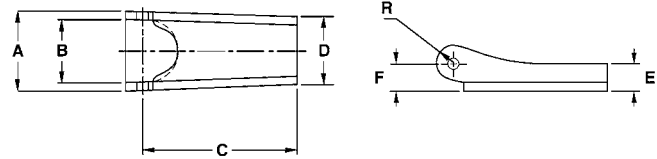

NOTE: Latches listed on this page cannot be used on Campbell's current design of integrated Sling and Hoist hooks. Please refer to the appropriate catalog pages for these hooks for proper replacement latch kits.

Size in.	mm	Size No.	916-G Kit		Universal Kit		Dimensions												Weight/ 100			
			Cat. No.	UPC No. 020418	Cat. No.	UPC No. 020418	A		B		C		D		E		F		R		lb	kg
1/4	6	2-22	3990101	072727	3991401	177088	23/32	18	9/16	14	1 1/4	32	5/8	16	1/4	6	1/4	6	5/32	4	3.3	1
5/16	8	3-23	3990201	072734	3991402	177095	23/32	18	9/16	14	1 3/8	39	39/64	16	1/4	6	1/4	6	5/32	4	3.7	2
--	--	4-24	3990301	072741	3991403	177101	15/16	24	25/32	20	1 17/32	43	15/16	24	9/32	7	9/32	7	3/16	5	5	2
3/8	10	5-25	3990401	072758	3991404	177118	15/16	24	25/32	20	1 11/16	43	15/16	24	9/32	7	9/32	7	3/16	5	5.6	3
--	--	6-26	3990501	072765	--	--	15/16	24	25/32	20	1 31/32	50	15/16	24	9/32	7	9/32	7	3/16	5	6.2	3
7/16	11	7-27	3990601	072772	3991405	177125	15/16	24	25/32	20	1 7/8	48	15/16	24	9/32	7	9/32	7	3/16	5	6.5	3
--	--	8-28	3990701	072789	--	--	9/32	32	1	25	2 3/8	60	1 9/32	32	3/8	10	9/16	14	17/64	7	12	5
1/2	13	9-29	3990801	072796	3991406	177132	1 9/32	32	1	25	2 11/16	68	1 9/32	32	3/8	10	9/16	14	17/64	7	16.5	7
--	--	10-30	3990901	072802	--	--	1 9/32	32	1	25	2 31/32	75	1 9/32	32	3/8	10	9/16	14	17/64	7	18.2	8
5/8	16	11-31	3991001	072819	3991407	177149	1 9/32	32	1	25	3 7/32	82	1 9/32	32	3/8	10	9/16	14	17/64	7	36	16
--	--	12-32	3991101	072826	3991408	177156	2	51	1 17/32	39	3 7/16	87	1 5/8	41	9/16	14	23/32	18	3/8	10	52	24
--	--	34	--	--	3991409	177163	2 3/16	56	1 3/4	45	4 11/32	110	1 3/4	45	9/16	14	1 1/16	18	13/32	10	70.7	32

WARNING

- Failure to follow the Instructions For Use and these warnings may cause death or serious injury.
- Loads may disengage from hook if proper procedures are not followed.
- A falling load may cause serious injury or death.
- The load must never be supported by the latch.
- Latches must always be inspected for wear or damage before use. If worn, distorted or damaged, discard and replace.
- Always stand clear of loads being lifted.



Hook Replacement Latches (PL Style)

- Replacement Latches for Eye & Swivel Hoist Hooks (PL Style)
- Replacement Latches for Cam-Alloy & Quik-Alloy Hooks (PL Style)
- New Latch Fits Integrated Forged Boss Design with Integrated Tip Hooks



Cat. No.	UPC No.	A Dim.	B Dim.	C Dim.	D Dim.	E Dim.	F Dim.	R Dim.	Latch Marking
7506295PL	020418306266	.75 in	.594 in	1.723 in	.515 in	.184 in	.32 in	.191 in	PL-3
7506495PL	020418306259	0.8 in	0.614 in	1.879 in	0.562 in	0.2 in	0.348 in	0.208 in	PL-4
7506695PL	020418306242	1 in	0.782 in	2.236 in	0.656 in	0.239 in	0.415 in	0.248 in	PL-5
7506895PL	020418306235	1.24 in	0.99 in	2.732 in	0.812 in	0.3 in	0.522 in	0.312 in	PL-7
7507095PL	020418295669	1.515 in	1.157 in	3.41 in	1 in	0.375 in	0.652 in	0.39 in	PL-8
7507295PL	020418295676	1.59 in	1.232 in	3.564 in	1.06 in	0.375 in	0.617 in	0.39 in	PL-9
7507495PL	020418295737	2.06 in	1.702 in	4.75 in	1.468 in	0.55 in	0.78 in	0.55 in	PL-10

Swivels

READ AND UNDERSTAND THESE WARNINGS AND INSTRUCTIONS BEFORE USING SWIVELS.

IMPORTANT: Instructions For Use

1. These swivels are designed for a straight line pull only.
2. These swivels are not designed to swivel under load.
3. Do not exceed working load limit (WLL). See table right.

Working Load Limits Swivels

in	Size	Carbon WLL	
	mm	lb	kg
1/4	6	850	386
5/16	8	1250	568
3/8	10	2250	1022
1/2	13	3600	1634

WARNING

- Failure to follow the Instructions For Use below and these warnings may cause death or serious injury.
- Use swivels only as indicated.
- Swivels must always be inspected for wear, distortion and damage before use. If worn, distorted or damaged, discard and replace.
- Always stand clear of loads being lifted.
- Do not angle load.

Eye & Eye Swivels (Import)

- Forged Steel
- Swivels Are Designed For Straight Line Pull Only
- These Swivels ARE NOT Designed to Swivel Under Load
- UPC Tagged
- DO NOT EXCEED THE WORKING LOAD LIMIT

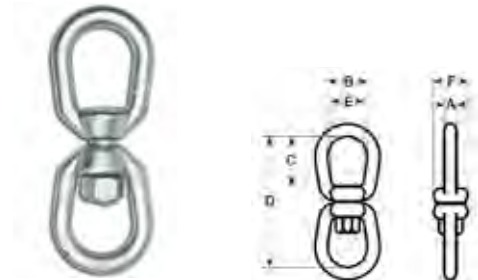

Trade Size	Cat. No.	Finish	A Dim.	B Dim.	C Dim.	D Dim.	E Dim.	F Dim.	Working Load Limit	Weight Each	Shelf Pack	Case Pack
3/16 in	T9630335	Galvanized	0.20 in	0.70 in	0.81 in	2.52 in	0.62 in	0.64 in	700 lb	0.11 lb	5	50
1/4 in	T9630435	Galvanized	0.25 in	0.73 in	1.02 in	3.00 in	0.65 in	0.69 in	850 lb	0.19 lb	5	50
5/16 in	T9630535	Galvanized	0.33 in	0.97 in	1.18 in	3.64 in	0.77 in	0.84 in	1250 lb	0.37 lb	5	50
3/8 in	T9630635	Galvanized	0.44 in	1.20 in	1.34 in	4.20 in	1.00 in	1.02 in	2250 lb	0.69 lb	5	25
1/2 in	T9630835	Galvanized	0.55 in	1.46 in	1.88 in	5.44 in	1.16 in	1.28 in	3600 lb	1.39 lb	5	25



Thimbles

Campbell® thimbles are all made of hot rolled, mild steel. They are all galvanized to ASTM A-153 Specification.

Heavy Wire Rope C-765-G



HEAVY WIRE ROPE THIMBLE

READ AND UNDERSTAND THESE WARNINGS AND INSTRUCTIONS BEFORE USING THIMBLES.

IMPORTANT: Instructions For Use

1. A thimble is a wear pad that protects the rope from cuts and kinking. Always use an appropriate thimble when making an eye in a rope.
2. When it is necessary to open a thimble to insert a fitting, make sure the points are properly aligned when the thimble is closed. Inspect carefully for cracks.
3. Thimbles are not designed for load carrying purposes; therefore working load limits have not been established.

WARNING

- Failure to follow the Instructions For Use below and these warnings may cause death or serious injury.
- Thimbles must always be inspected for cracks and wear before use. If worn, distorted or damaged, discard and replace.
- Use thimbles only as indicated.
- The thimble size must exactly correspond to the diameter of the rope being used. Never use a smaller thimble, because it will pinch the rope and cause broken and/or displaced wires.

FITTINGS

Heavy Wire Rope Thimbles, Galvanized, C-765-G

- Standard Material: Hot Rolled, Mild Steel
- Imported
- A Wear Pad That Protects the Rope From Cuts, Kinking and Abrasions. Always Use An Appropriate Thimble When Making An Eye in a Rope.
- When it is Necessary to Open a Thimble to Insert a Fitting, Make Sure the Points are Properly Aligned When the Thimble is Closed. Inspect Carefully for Cracks.
- Thimbles ARE NOT Designed for Load Carrying Purposes; Therefore Working Load Limits Have Not Been Established.

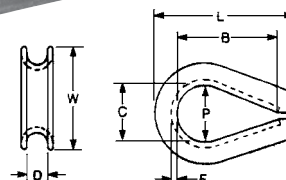

Trade Size	Cat. No.	UPC No.	B Dim.	C Dim.	D Dim.	F Dim.	L Dim.	P Dim.	W Dim.	Weight Each
1/4 in	6260201	020418091711	1-5/8 in	7/8 in	9/32 in	1/16 in	2-1/8 in	13/16 in	1-1/2	0.07 lb
5/16 in	6260202	020418091728	1-7/8 in	1-1/16 in	3/8 in	5/64 in	2-1/2 in	15/16 in	1-13/16	0.12 lb
3/8 in	6260203	020418091735	2-1/8 in	1-1/8 in	7/16 in	7/64 in	3 in	1-1/16 in	2-1/8	0.19 lb
1/2 in	6260205	020418091759	2-3/4 in	1-1/2 in	5/8 in	9/64 in	3-5/8 in	1-7/16 in	2-11/16	0.49 lb
5/8 in	6260206	020418091766	3-1/4 in	1-3/4 in	11/16 in	5/32 in	4-1/4 in	1-5/8 in	3-1/8	0.72 lb
3/4 in	6260207	020418091773	3-3/4 in	2 in	13/16 in	7/32 in	5 in	1-7/8 in	3-13/16	1.41 lb

Eyebolts

Campbell carbon steel eyebolts are all drop-forged and normalized.

READ AND UNDERSTAND THESE WARNINGS AND INSTRUCTIONS AND FOLLOW ALL EYEBOLT SAFETY INFORMATION PRESENTED HERE BEFORE USING EYEBOLT ASSEMBLIES.

IMPORTANT: Instructions For Use

1. Make sure the eyebolt is properly seated by screwing it down completely and tightening the nut securely against the load.
2. An eyebolt must be installed into a tapped hole with a minimum depth of two times the shank diameter.
3. Make sure the threads on the shank and in the hole are clean and undamaged.
4. Loads must always be applied parallel to the plane of the eye and never across the plane of the eye.
5. Always lift the load with a steady, even pull. Do not shock load.
6. Do not exceed working load limit (WLL). See table. The standard WLL's are established for a vertical pull.
7. Use only the heavy hex nuts supplied with the eyebolts.

WARNING

- Failure to follow the Instructions For Use below and these warnings may cause death or serious injury.
- Loads may slip or fail if proper eyebolt assembly and lifting procedures are not used.
- A falling load can seriously injure or kill.
- Eyebolts must always be inspected for wear and distortion before use. If worn, distorted or damaged, discard and replace.
- Do not use regular nut eyebolts for angular lifting.
- Never machine, cut or grind an eyebolt.
- Always stand clear of loads being lifted.

Plain Pattern Eyebolts

- Drop-Forged Carbon Steel
- Working Load Limits are Established for a Vertical Pull
- Angular Lifts Place Additional Stress on Eyebolt and Should be Avoided
- Plain Pattern Eyebolts Should be Firmly Seated with at Least 90% of the Thread Engaged with Threads Close to the Eye Fully Engaged
- Eyebolts Should Never be Ground, Machined, Metal Stamped, Welded or Altered in Any Way
- Eyebolt Capabilities Can be Affected by Temperature, DO NOT Use Carbon Steel Eyebolts at Temperatures Below 32° F (0° C)
- Eyebolts Should be Routinely Inspected
- Design Factor: 5 to 1
- Meets or Exceeds All Requirements of ASME B18.15 and Tested to ASTM A489
- DO NOT EXCEED THE WORKING LOAD LIMIT



Cat. No.	Thread Size	Length Under Eye	Eye Diameter; Inside	Eye Diameter; Outside	Product Weight
7100121	1/4 - 20	1 in	3/4 in	1-3/16 in	0.06 lb
7100123	3/8 - 16	1-1/4 in	1 in	1-21/32 in	0.15 lb
7100124	1/2 - 13	1-1/2 in	1-3/16 in	2-1/16 in	0.30 lb
7100125	5/8 - 11	1-3/4 in	1-3/8 in	2-1/2 in	0.61 lb
7100126	3/4 - 10	2 in	1-1/2 in	2-13/16 in	0.98 lb



Shoulder Pattern Eyebolts

- Drop-Forged Carbon Steel
- Working Load Limits are Established for a Vertical Pull
- Angular Lifts Place Additional Stress on Eyebolt and Should be Avoided
- Shoulder Pattern Eyebolts are Recommended for Use Whenever Possible Since There is no Guarantee that a Load Will Not be Subjected to an Angular Lift and Forces
- Eyebolts Should Never be Ground, Machined, Metal Stamped, Welded or Altered in Any Way
- Eyebolt Capabilities Can be Affected by Temperature, DO NOT Use Carbon Steel Eyebolts at Temperatures Below 32° F (0° C)
- Eyebolts Should be Routinely Inspected
- Design Factor: 5 to 1
- Meets or Exceeds All Requirements of ASME B18.15 and Tested to ASTM A489
- DO NOT EXCEED THE WORKING LOAD LIMIT



Cat. No.	Thread Size	Length Under Eye	Eye Diameter; Inside	Eye Diameter; Outside	Product Weight
7100222	5/16 - 18	1-1/8 in	7/8 in	1-7/16 in	0.110 lb
7100223	3/8 - 16	1-1/4 in	1 in	1-21/32 in	0.180 lb
7100224	1/2 - 13	1-1/2 in	1-3/16 in	2-1/16 in	0.350 lb
7100225	5/8 - 11	1-3/4 in	1-3/8 in	2-1/2 in	0.700 lb
7100226	3/4 - 10	2 in	1-1/2 in	2-13/16 in	1.100 lb
7100227	7/8 - 9	2-1/4 in	1-11/16 in	3-1/4 in	1.700 lb
7100228	1 - 8	2-1/2 in	1-13/16 in	3-9/16 in	2.360 lb



BLOCKS

Wood Shell Block.....	89
Utility Block.....	89
Gin or Roofer's Block.....	90





Campbell® Blocks

Begun as a forging company in 1834, Campbell/Brewer-Titchener first manufactured horse harnesses, then carriage hardware, then horseless carriage hardware. From hardware for power lines in the 1930's, to forgings for the war effort in the 40's. Campbell/Brewer-Titchener began making high quality, wire rope and chain fittings in the 50's. Today the line includes well over 1000 different types and sizes of drop-forged eyebolts, wire rope clips, shackles, swivels, hooks, turnbuckles and more.

Since 1973, when Campbell/Brewer-Titchener acquired the Boston & Lockport Corporation, the brand has also been a leading name in high quality tackle blocks. This line includes blocks with wood, metal and nylon shells for fiber, manila or wire rope. Many options are offered: a wide selection of drop forged hooks, eyes and shackles; and various bushing types. Replacement sheaves are also available.

Definitions: Important Block Terms

Bight: The area formed by the angle of the incoming and outgoing line (see figure #2, page 133).

Fairleading: To change the direction of pull on a lead rope.

Line Pull: The line pull is the amount of force transmitted to the rope by the winch, or other forms of power. All Working Load Limits are based on "resultant loads."

Mechanical Advantage: The amount by which a block system multiplies the force (or load) applied to it.

Parts of Line: The number of lines needed for a given load.

LOADS

Ton: Ton is equal to 2240 LB (Long Ton) unless otherwise noted.

Proof Test: Campbell® has the ability to proof test all blocks and fittings. The usual proof test is twice the Working Load Limit. Proof testing and certifications can be performed at customer's request, for a nominal charge.

Side Load: The result of a load which is applied off-center.

Shock Load: The result of the rapid application of force (such as impacting and /or jerking), or the rapid movement of a static load.

Ultimate Load: The average load at which a product fails, or no longer supports the load.

Working Load Limit: The Working Load Limit (WLL) is the maximum resultant load which should ever be applied to the product in service, even when new, and when the load is uniformly applied in direct tension.

Caution should be used when determining the resultant load, as the manner in which the product is used can increase the load. (Refer to Figure 1, page 87)

Warning Statement - Blocks

BLOCK USE AND MAINTENANCE INFORMATION:

Read, understand and follow these warnings and instructions prior to selection, maintenance and use of tackle block systems.

WARNING



Falling load may cause death or serious injury

- Do Not exceed "Working Load Limit"
- Do Not stand under load or in bight
- Do Not side load or shock load
- Do Not use worn or damaged block or rope

IMPORTANT: Read and understand the instructions and warnings before using this block. It is the responsibility of the employer to place this information into the hands of the operator.

INSTRUCTIONS FOR USE

- Do Not exceed the "Working Load Limit" of the block(s) being used. Check the label on the block or refer to the catalog
- Do Not exceed the "Working Load Limit" or operating limitations of the rope being used. If uncertain, consult the rope manufacturer
- Use the recommended rope diameter. See the label.
- Know the weight of the load to be lifted and the conditions of the lift. For example, a flat load embedded in mud will require extra pulling power to break the vacuum and may create a shock load
- Be sure there are no impediments in the way of the lift that could snag the load and increase the load on the block(s)
- Blocks used above or aloft should be attached with shackles
- Do Not side load or shock load blocks. When using snatch blocks, be sure that the block is closed properly before the load is applied
- Snatch blocks should not be used for hoisting: they should be used for fairleading only
- Do Not stand under the load or in the bight area. Do Not stand in the direct line of pull of any load
- Be sure the structural member to which the block is being attached is strong enough to support the load
- Assure proper lubrication of the block. Improper lubrication can lead to block failure. Read and follow lubrication schedules.

ADVERTENCIA

Para prevenir la posibilidad de una lesión personal sería:

- **NO EXCEDA** los límites de carga de las cadenas o componentes.
- **NO LA UTILICE** para cargar hacia arriba o para izar.
- **NO LA UTILICE** si la cadena o los componentes están visualmente distorsionados o gastados.

WARNING

To prevent the possibility of serious bodily injury:

- **DO NOT EXCEED** the working load limits for chain or components.
- **DO NOT USE** for overhead lifting or hoisting.
- **DO NOT USE** if the chain or components are visibly distorted or worn.

Important Information

Block systems must be properly designed, used and maintained. A continual inspection program should be undertaken to discover gouges, distortion, cracks, elongation (or stretching), spread in the throat openings of hooks, severe wear or other damage. Any abuse, misuse or alteration may lessen the load a block system will sustain. Some examples of changes are as follows:

- Twisting or side loading
- Disfigurement
- Corrosion
- Shock loading
- Use for a purpose other than that for which a particular block was intended
- Use to carry a load in excess of the Working Load Limit

(continued)



Blocks consist of one or more sheaves fitted in a wood or metal shell. Blocks are supported by a fitting attached to the strap of the block. These blocks are intended to be used in conjunction with other components in a load-sustaining system to gain mechanical advantage. Care should be taken to select components of compatible type, size and Working Load Limit.

Work Load Limits shown in Hillman Group literature are applicable to new blocks, or blocks in “as new” condition.

Block Inspection and Maintenance

- Carefully examine the block(s) and rope(s) for wear and damage before each use
- Do not use a block if the sheaves do not turn freely. Sheaves must turn freely. Tight sheaves could indicate worn bushings or bearings
- Do not use a block with excessive play in the sheave. Check for excessive play in the sheave. Excessive play could indicate worn bushings or bearings
- Do not use a block with a loose becket bolt or rope splice. Check the becket bolt holding the dead end of the rope; the becket bolt should be tight. The rope splice on the becket should also be tight
- Do not use a block with worn or frayed rope. Check the condition of the rope for fraying
- Do not use a block with a damaged hook latch. Hooks on blocks should have a latch in proper operating condition. If the latch does not engage the tip of the hook, the hook could be sprung or opened due to an overload on a previous lift

Sheave, Bushing and Bearing Information

Iron Bushings (common bore) are very low speed lines and very infrequent use (high bearing friction).

Bronze Bushings (self lubricating bronze, graphite bronze and pressure lubrication bronze) are for slow line speeds.

Self-lubricating bronze and graphite bronze bushings are for infrequent use (moderate bearing friction).

Pressure lubrication bronze bushings are for frequent use at greater loads (moderate bearing friction).

The performance of bronze bushings is best determined by the “PV Factor” (maximum pressure velocity) at which the bearing is operating. This is the relationship between bearing pressure and bearing surface velocity. Brewer-Titchener™ bronze bushings have the following material properties:

Maximum Bearing Pressure (BP): 4,500 pounds per square inch

Maximum Bearing Velocity (BV): 1,200 feet per minute

Maximum Pressure Velocity Factor (PV): 55,000

(Due to material property relations, the maximum BP times the maximum BV is not equal to the maximum

To calculate Bearing Pressure (BP): $\text{Line Pull} \times \text{Bight Angle Factor} \times \text{Shaft Diameter} \times \text{Hub Width}$

To calculate Bearing Velocity (BV): $\text{PV} \times \text{BP}$

To calculate Line Speed: $\text{BV} \times (\text{Tread Diameter} + \text{Rope Diameter}) \times \text{Shaft Diameter}$

These formulas can be used to determine the maximum allowable line speed for a given total sheave load. The maximum allowable line speed should be equal to or exceeding the required line speed. If the required line speed is greater than the calculated maximum allowable line speed, increase the shaft diameter and/or the hub width. For example:

Using a 12” diameter sheave (tread diameter = 10.25”; wire diameter = 0.75”; shaft diameter = 1.50”; hub width = 1.62”), a 5,000 lb. line pull and a 90° bight angle determine the allowable line speed.

$$\text{BP} = (5,000 \text{ lb.}) (\text{line pull}) \times (1.41^*) / (1.50'' \times 1.62'') (\text{bight angle factor}) / (\text{shaft dia.}) = 2,901 \text{ psi (hub width)}$$

$$\text{BV} = (55,000 \text{ psi.}) (\text{PV factor}) / 2,901 (\text{BP}) = 19 \text{ FPM Allowable}$$

$$\text{Line Speed} = 19 (\text{BV}) \times (10.25'' + 0.75'') (\text{tread dia.} + \text{rope dia.}) / 1.50'' (\text{shaft dia.}) = 139 \text{ FPM Allowable}$$

Load on Blocks

⚠ WARNING

The Working Load Limit (WLL) is the maximum resultant load which should ever be applied to a block and its fittings. Blocks used to fairlead (single sheave and snatch blocks) can be subjected to a load greater than the weight being lifted or pulled.

Results of Applied Loads on Single Blocks

Figure No. 1



⚠ WARNING

The total weight (load) on a single sheave block or snatch block varies with the bight angle between the incoming and outgoing line to the block (see Figure 2).

BLOCKS

Figure No. 2

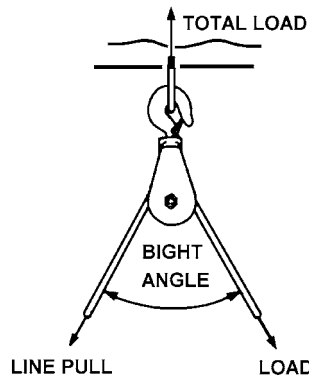



Load on Blocks (continued)

To determine this load:

1. Determine the bight angle of the line.
2. Refer to Table 1 for the corresponding angle factor.
3. Multiply the pull on the line or the weight of the load (line pull) by the angle factor to obtain the load on the block.

Bight Angle Factor

Table 1

Angle	Factor	Angle	Factor
0°	2.00	100°	1.29
10°	1.99	110°	1.15
20°	1.97	120°	1.00
30°	1.93	130°	0.84
40°	1.87	135°	0.76
45°	1.84	140°	0.68
50°	1.81	150°	0.52
60°	1.73	160°	0.35
70°	1.64	170°	0.17
80°	1.53	180°	0.00
90°	1.41	—	—

Figure No. 3

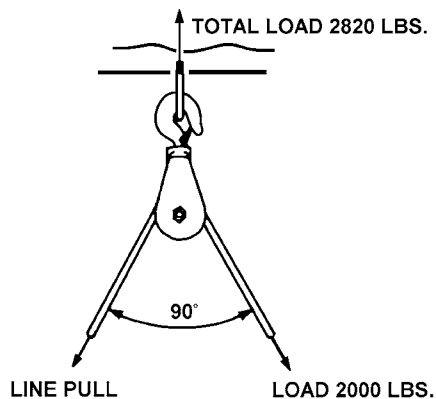

Regular Wood Shell Blocks for Manila Rope

- Hard Wood Shells
- Model 3001 Single Sheave, Model 3002 Double Sheave, Model 3003 Triple Sheave
- Drop Forged Fittings
- Bronze Self-Lubricating Bushings
- Galvanized Metal Parts
- Working Loads are Resultant Working Loads
- DO NOT EXCEED THE WORKING LOAD LIMIT



Cat. No.	UPC No.	Block Size	Sheaves	Fitting Type	Rope Diameter	Sheave Size - OD	Rim Thickness	Center Pin Diameter	Working Load Limit	Weight Each
7205436	020418165900	4 in	Single	Round Loose Hook "AF"	1/2 in	2-1/4 in	5/8 in	3/8 in	1000 lb	1.90 lb
7206936	020418165955	4 in	Double	Round Loose Hook "AF"	1/2 in	2-1/4 in	5/8 in	3/8 in	1400 lb	3.00 lb
7208536	020418166006	4 in	Triple	Round Loose Hook "AF"	1/2 in	2-1/4 in	5/8 in	3/8 in	1800 lb	3.58 lb
7205434	020418104282	4 in	Single	Swivel Hook with Latch "G"	1/2 in	2-1/4 in	5/8 in	3/8 in	1000 lb	2.00 lb
7206934	020418105210	4 in	Double	Swivel Hook with Latch "G"	1/2 in	2-1/4 in	5/8 in	3/8 in	1400 lb	3.00 lb
7208534	020418106118	4 in	Triple	Swivel Hook with Latch "G"	1/2 in	2-1/4 in	5/8 in	3/8 in	1800 lb	4.00 lb
7205435	020418104299	4 in	Single	Screw Pin Anchor Shackles "K"	1/2 in	2-1/4 in	5/8 in	3/8 in	1000 lb	2.00 lb
7206935	020418105227	4 in	Double	Screw Pin Anchor Shackles "K"	1/2 in	2-1/4 in	5/8 in	3/8 in	1400 lb	3.00 lb
7205536	020418165917	5 in	Single	Round Loose Hook "AF"	5/8 in	3 in	3/4 in	3/8 in	1200 lb	2.80 lb
7207036	020418165962	5 in	Double	Round Loose Hook "AF"	5/8 in	3 in	3/4 in	3/8 in	1800 lb	4.20 lb
7205535	020418104442	5 in	Single	Screw Pin Anchor Shackles "K"	5/8 in	3 in	3/4 in	3/8 in	1200 lb	2.50 lb
7207035	020418105371	5 in	Double	Screw Pin Anchor Shackles "K"	5/8 in	3 in	3/4 in	3/8 in	1800 lb	4.00 lb
7205636	020418165924	6 in	Single	Round Loose Hook "AF"	3/4 in	3-1/2 in	1 in	1/2 in	1800 lb	4.00 lb
7207136	020418165979	6 in	Double	Round Loose Hook "AF"	3/4 in	3-1/2 in	1 in	1/2 in	2500 lb	8.00 lb
7205635	020418104596	6 in	Single	Screw Pin Anchor Shackles "K"	3/4 in	3-1/2 in	1 in	1/2 in	1800 lb	4.00 lb
7207135	020418105524	6 in	Double	Screw Pin Anchor Shackles "K"	3/4 in	3-1/2 in	1 in	1/2 in	2500 lb	6.50 lb

BLOCKS

Hand Line Utility Block, CHB300 & CHB303

- For Stringing Conductor Cable or Fiber Rope Applications
- Side Opening Block with Zinc Plated Swivel Hook with Safety Latch
- CHB300 features Ultra-lightweight Block and Sheave Molded From Reinforced Nylon Fiberglass High Di-Electric Material and 1,000 lb. Safe Working Load Limit
- CHB303 features Lightweight Aluminum Alloy Block and Sheave Construction with Permanently Lubricated Sheave and Safety-tethered Locking Pin and Strongest in Class 1,500 lb. Safe Working Load Limit
- 3" Sheaves - Blocks Can Accommodate Rope Through 5/8" Diameter
- Design Factor: 3 to 1



Cat. No.	Block Size	Fitting Type	Rope Size	Working Load Limit	Weight Each
7380300	3 in	Hook w/Latch	5/8 in	1000 lb	1.90 lb
7380303	3 in	Hook w/Latch	5/8 in	1500 lb	2.50 lb



Gin or Roofer's Block for Manila Rope

- Model 3061V - Furnished with A Drop-Forged, Flat Swivel Hook with Latch
- Roller Bushing
- Blue Painted Finish
- Working Loads are Resultant Working Loads
- Lift Should Not Exceed 500 lbs.
- DO NOT EXCEED THE WORKING LOAD LIMIT



Cat. No.	UPC No.	Block Size	Sheaves	Fitting Type	Rope Diameter	Sheave Size - OD	Rim Thickness	Center Pin Diameter	Working Load Limit	Weight Each
7269812-02	020418349775	12 in	Single	Swivel Hook with Latch "V"	1 in	12 in	1-3/8 in	5/8 in	1000 lb	13 lb

BLOCKS



SLINGS

Cam Alloy Sling Hooks.....	106
Replacement Latches (IL Style)	107
Cam Alloy Foundry Hooks.....	107
Cam Alloy Grab Hooks	108
Eye Hooks.....	108
Swivel Hooks	109
Self Locking Hook Repair Kit	109
Links	110
Coupling Links	114
Sling Hooks (Regular and Latched).....	115
Replacement Latches (PL Style).....	116
Quik Alloy Grab Hooks	116
Clevis Hooks	117
Cam Alloy Hooks "S" and "J"	117
Field I.D. Tags.....	118





Campbell® Slings

Founded in 1919, Campbell is the largest manufacturer of welded and weldless chain in the United States. Users of Campbell chain can select from a wide range of working load capacities including proof coil, high test, transport and alloy; finishes including self-colored, Blu-Krome®, galvanized and bright color polycoated; links that are short, long, twisted, locked, looped, even stamped from flat stock. Several chain types are even available in solid brass and bronze.

Campbell chains and assemblies, including slings for overhead lifting, tie-downs and binder chains, have earned for the manufacturer an outstanding reputation for quality.

Campbell's Chain Sling Program Surveys, Seminars and Schools

Users of Campbell Chain Slings may receive annual surveys to assure compliance with OSHA standards. These thorough in-plant inspections by qualified Hillman Group or Campbell personnel can point out potential problems, encourage proper handling and storage, show how to reduce inventory and increase productivity.

Upon completion of the survey, Campbell will provide a complete report on the status of every Campbell chain sling and clamp for your OSHA compliance files.

To instruct customers in the proper use of slings as well as in maintenance and safety procedures, Campbell will conduct seminars in your plant or at its local sling repair center. Further, if interested, we'll train your plant personnel to conduct their own sling survey in a one and a half day "school" held at our York, Pennsylvania plant. Upon completion of this school, your personnel will be fully qualified to perform OSHA compliance inspections.

Campbell's sling repair centers across the U.S. help make the most of your company's chain sling investment. Wherever economical reconditioning is possible, Campbell will advise you on estimated cost. A nearby center will then repair, proof-test and issue new certificates of test to put your slings back to work quickly.

To Supplement Your Sling Chain Program

Campbell®

**Slings, Surveys
and Safety**

- Chain Sling Inspection
- Rejection Criteria
- Proper Use of Slings
- Safe Lifting Practices
- Clamp Operating Guide



Number T550840

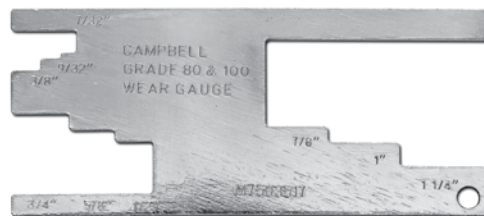

Number 7503515

Campbell Service Centers

Chicago Area

Alloy Sling Chain
Industries, LTD
1406 West 175th Street
East Hazelcrest, IL 60429
Phone: (708) 647-4900
Toll Free: (800) 255-8973
Fax: (708) 647-4993

Cleveland Area

Commercial Group Lifting
Products/Great Lakes
5213 Grant Avenue
Cleveland, OH 44125
Phone: (216) 641-4100
Fax: (216) 641-1814

Detroit Area

Commercial Group Lifting
Products/Detroit Chain
12801 Universal Drive
Taylor, MI 48180
Phone: 734-947-4000
Fax: 734-947-4004

Philadelphia Area

I & I Sling Company
2626 Market St.
Box 2423
Aston, PA 19014
Phone: (610) 485-8500
Fax: (610) 494-5835

Pittsburgh Area

Certex-Safety Sling
919 Fulton Street
Pittsburgh, PA 15233
Phone: (412) 231-6684
Fax: (412) 231-6695

San Francisco Area

Carpenter Rigging & Supply
28800 Hesperian Blvd.
Hayward, CA 94545
Phone: (415) 285-1954
Fax: (415) 285-0176

Quebec, Canada

St-Pierre Chains & Slings, LTD
7690 Jarry Street E
Anjou, Quebec
Canada H1J 2M3
Phone: (514) 354-4219
Fax: (514) 354-5059



Dependable Chain Slings. Strong National Service Network.

Our service network is composed of ten authorized service centers in all, each strategically located across the United States and Canada, to offer fast, dependable service for your chain sling requirements.

Specifically, our chain sling service program offers on-site chain inspections, including a complete report showing the status of all chain slings and Campbell clamps for your OSHA compliance files. All chain slings are fabricated precisely to Campbell's manufacturing specifications. The program also includes in-plant seminars to educate your employees in proper and safe chain sling procedures. Our Campbell Chain facility in York, PA even conducts chain sling schools, free of charge.

Each of our eleven authorized repair facilities has technical and sales support ready to assist you in resolving your overhead lifting needs. Which further proves what we have said all along: Dependable chain slings, strong national service network.



Rated Loads For Grade 80 (System 8) Alloy Steel Chain Slings

Rated Load for Grade 80 Alloy Steel Chain Slings

Chain Size Nominal		Single Leg Sling - 90° - Horizontal Loading		Rated load Double Leg Sling and Single Basket at Horizontal Angle						Triple and Quadruple Leg Sling and Double Basket at Horizontal Angle					
				60°		45°		30°		60°		45°		30°	
in.	mm	lb	kg	lb	kg	lb	kg	lb	kg	lb	kg	lb	kg	lb	kg
7/32	5.5	2,100	950	3,600	1,650	3,000	1,350	2,100	950	5,500	2,450	4,400	2,000	3,200	1,450
9/32	7	3,500	1,600	6,100	2,750	4,900	2,250	3,500	1,600	9,100	4,150	7,400	3,400	5,200	2,400
3/8	10	7,100	3,200	12,300	5,550	10,000	4,500	7,100	3,200	18,400	8,300	15,100	6,800	10,600	4,800
1/2	13	12,000	5,400	20,800	9,450	17,000	7,700	12,000	5,400	31,200	14,150	25,500	11,550	18,000	8,200
5/8	16	18,100	8,200	31,300	14,200	25,600	11,600	18,100	8,200	47,000	21,300	38,400	17,400	27,100	12,300
3/4	20	28,300	12,800	49,000	22,250	40,000	18,150	28,300	12,800	73,500	33,400	60,000	27,250	42,400	19,300
7/8	22	34,200	15,500	59,200	26,850	48,400	21,900	34,200	15,500	88,900	40,250	72,500	32,900	51,300	23,250
1	26	47,700	21,600	82,600	37,500	67,400	30,600	47,700	21,600	123,900	56,250	101,200	45,950	71,500	32,500
1 1/4	32	72,300	32,800	125,200	56,800	102,200	46,400	72,300	32,800	187,800	85,200	153,400	69,600	108,400	49,200

Rated Loads for Grade 80 Alloy Steel Chain Slings - Choker Hitches



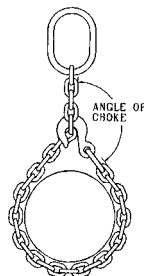

Chain Size Nominal		Single Leg		Double Leg and Single Baskets						Triple and Quadruple Leg; Double Baskets					
		90°		60°		45°		30°		60°		45°		30°	
in.	mm	lb	kg	lb	kg	lb	kg	lb	kg	lb	kg	lb	kg	lb	kg
7/32	5.5	1,700	750	2,900	1,300	2,400	1,100	1,700	750	4,400	1,950	3,500	1,600	2,550	1,150
9/32	7	2,800	1,300	5,000	2,200	3,900	1,800	2,800	1,300	7,300	3,300	5,900	2,700	4,150	1,900
3/8	10	5,700	2,550	9,800	4,450	8,000	3,650	5,700	2,550	14,700	6,650	12,100	5,450	8,500	3,850
1/2	13	9,600	4,300	16,600	7,550	13,600	6,150	9,600	4,300	25,000	11,300	20,400	9,250	14,400	6,550
5/8	16	14,500	6,550	25,000	11,350	20,500	9,300	14,500	6,550	37,600	17,050	30,700	13,900	21,700	9,850
3/4	20	22,600	10,250	39,200	17,800	32,000	14,500	22,600	10,250	58,800	26,700	48,000	21,800	33,900	15,450
7/8	22	27,400	12,400	47,400	21,500	38,700	17,500	27,400	12,400	71,100	32,200	58,000	26,300	41,000	18,600
1	26	38,200	17,300	66,100	30,000	53,900	24,500	38,200	17,300	99,100	45,000	81,000	36,750	57,200	26,000
1-1/4	32	57,800	26,250	100,200	45,450	81,800	37,100	57,800	26,250	150,200	68,150	122,700	55,700	86,700	39,350

Note: Angle of choke should be greater than 120°

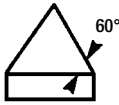
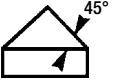

Rated Loads For Grade 80 (System 8) Alloy Steel Chain Slings

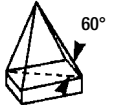
Rated Load for Grade 80 Alloy Steel Chain Slings

Chain Size Nominal		Single Leg Sling - 90° - Horizontal Loading		Rated load Double Leg Sling and Single Basket at Horizontal Angle						Triple and Quadruple Leg Sling and Double Basket at Horizontal Angle					
				60°		45°		30°		60°		45°		30°	
															
in.	mm	lb	kg	lb	kg	lb	kg	lb	kg	lb	kg	lb	kg	lb	kg
7/32	5.5	2,100	950	3,600	1,650	3,000	1,350	2,100	950	5,500	2,450	4,400	2,000	3,200	1,450
9/32	7	3,500	1,600	6,100	2,750	4,900	2,250	3,500	1,600	9,100	4,150	7,400	3,400	5,200	2,400
3/8	10	7,100	3,200	12,300	5,550	10,000	4,500	7,100	3,200	18,400	8,300	15,100	6,800	10,600	4,800
1/2	13	12,000	5,400	20,800	9,450	17,000	7,700	12,000	5,400	31,200	14,150	25,500	11,550	18,000	8,200
5/8	16	18,100	8,200	31,300	14,200	25,600	11,600	18,100	8,200	47,000	21,300	38,400	17,400	27,100	12,300
3/4	20	28,300	12,800	49,000	22,250	40,000	18,150	28,300	12,800	73,500	33,400	60,000	27,250	42,400	19,300
7/8	22	34,200	15,500	59,200	26,850	48,400	21,900	34,200	15,500	88,900	40,250	72,500	32,900	51,300	23,250
1	26	47,700	21,600	82,600	37,500	67,400	30,600	47,700	21,600	123,900	56,250	101,200	45,950	71,500	32,500
1 1/4	32	72,300	32,800	125,200	56,800	102,200	46,400	72,300	32,800	187,800	85,200	153,400	69,600	108,400	49,200

Rated Loads for Grade 80 Alloy Steel Chain Slings - Choker Hitches

Chain Size Nominal		Single Leg		Double Leg and Single Baskets						Triple and Quadruple Leg; Double Baskets					
		90°		60°		45°		30°		60°		45°		30°	
in.	mm	lb	kg	lb	kg	lb	kg	lb	kg	lb	kg	lb	kg	lb	kg
7/32	5.5	1,700	750	2,900	1,300	2,400	1,100	1,700	750	4,400	1,950	3,500	1,600	2,550	1,150
9/32	7	2,800	1,300	5,000	2,200	3,900	1,800	2,800	1,300	7,300	3,300	5,900	2,700	4,150	1,900
3/8	10	5,700	2,550	9,800	4,450	8,000	3,650	5,700	2,550	14,700	6,650	12,100	5,450	8,500	3,850
1/2	13	9,600	4,300	16,600	7,550	13,600	6,150	9,600	4,300	25,000	11,300	20,400	9,250	14,400	6,550
5/8	16	14,500	6,550	25,000	11,350	20,500	9,300	14,500	6,550	37,600	17,050	30,700	13,900	21,700	9,850
3/4	20	22,600	10,250	39,200	17,800	32,000	14,500	22,600	10,250	58,800	26,700	48,000	21,800	33,900	15,450
7/8	22	27,400	12,400	47,400	21,500	38,700	17,500	27,400	12,400	71,100	32,200	58,000	26,300	41,000	18,600
1	26	38,200	17,300	66,100	30,000	53,900	24,500	38,200	17,300	99,100	45,000	81,000	36,750	57,200	26,000
1-1/4	32	57,800	26,250	100,200	45,450	81,800	37,100	57,800	26,250	150,200	68,150	122,700	55,700	86,700	39,350

Note: Angle of choke should be greater than 120°

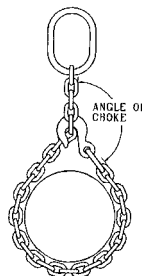



Rated Loads For Grade 100 (System 10) Alloy Steel Chain Slings

Rated Load for Grade 100 Alloy Steel Chain Slings

Chain Size Nominal		Single Leg Sling - 90° - Horizontal Loading		Rated load Double Leg Sling and Single Basket at Horizontal Angle						Triple and Quadruple Leg Sling and Double Basket at Horizontal Angle					
				60°		45°		30°		60°		45°		30°	
				Double at 60°		Double at 45°		Double at 30°		Quad at 60°		Quad at 45°		Quad at 30°	
in.	mm	lb	kg	lb	kg	lb	kg	lb	kg	lb	kg	lb	kg	lb	kg
9/32	7	4,300	1,950	7,400	3,400	6,100	2,750	4,300	1,950	11,200	5,050	9,100	4,150	6,400	2,950
3/8	10	8,800	4,000	15,200	6,950	12,400	5,650	8,800	4,000	22,900	10,400	18,700	8,500	13,200	6,000
1/2	13	15,000	6,800	26,000	11,800	21,200	9,600	15,000	6,800	39,000	17,650	31,800	14,450	22,500	10,200
5/8	16	22,600	10,300	39,100	17,750	32,000	14,500	22,600	10,300	58,700	26,650	47,900	21,750	33,900	15,400
3/4	20	35,300	16,000	61,100	27,700	49,900	22,650	35,300	16,000	91,700	41,550	74,900	33,950	53,000	24,000
7/8	22	42,700	19,400	74,000	33,500	60,400	27,350	42,700	19,400	110,900	50,250	90,600	41,050	64,000	29,050

Rated Loads for Grade 100 Alloy Steel Chain Slings - Choker Hitches

Chain Size Nominal		Single Leg		Double Leg and Single Baskets						Triple and Quadruple Leg; Double Baskets					
		90°		60°		45°		30°		60°		45°		30°	
in.	mm	lb	kg	lb	kg	lb	kg	lb	kg	lb	kg	lb	kg	lb	kg
9/32	7	3,500	1,600	6,100	2,750	4,900	2,250	3,500	1,600	9,100	4,150	7,400	3,400	5,200	2,400
3/8	10	7,100	3,200	12,300	5,550	10,000	4,550	7,100	3,200	18,400	8,300	15,100	6,800	10,600	4,800
1/2	13	12,000	5,400	20,800	9,450	17,000	7,700	12,000	5,400	31,200	14,150	25,500	11,550	18,000	8,200
5/8	16	18,100	8,200	31,300	14,200	25,600	11,600	18,100	8,200	47,000	21,300	38,400	17,400	27,100	12,300
3/4	20	28,300	12,800	49,000	22,250	40,000	18,150	28,300	12,800	73,500	33,400	60,000	27,250	42,400	19,300
7/8	22	34,200	15,500	59,200	26,850	48,400	21,900	34,200	15,500	88,900	40,250	72,500	32,900	51,300	23,250

Note: Angle of choke should be greater than 120°

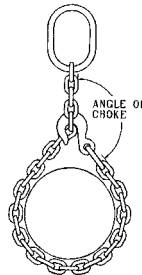

Cam-Alloy Chain Slings

Campbell manufactures a complete line of standard sling assemblies, as well as assemblies to customer specifications. This work is done at authorized Campbell Sling Service Centers located in strategic areas of the country to provide maximum customer service.

Important Chain Terms

WORKING LOAD LIMIT

The “working load limit” (rated capacity) is the maximum combined static and dynamic load in pounds or kilograms which should ever be applied to the product in service, even when the product is new, and when the load is uniformly applied in direct tension to the product.

PROOF TEST

The “proof test” is a quality control test applied to chain for the purpose of verifying weld and material quality. It is the minimum force in pounds or newtons that the chain has withstood in direct tension as part of the manufacturing process. Proof testing assures that the chain is more than capable of performing at its rated working load limit. Proof test loads are a manufacturing integrity test and shall not be used as criteria for service or design purposes. All Campbell chain and components are proof tested in accordance with the applicable ASTM, NACM, OSHA and AISI/ASME requirements.

Certificate of Test and Identification Tags

Campbell provides information in several forms that enables purchasers and users to operate safely and effectively in conformity with OSHA requirements. The drop forged Identification Tag is attached to the Master End Coupling link of each chain sling and provides the following lifetime information:

- Grade
- Working Load Limit (at a specific angle of lift)
- Size
- Serial number
- Reach
- Type

A Certificate of Test is provided for every Campbell manufactured chain sling. The Campbell Certificate contains all of the information provided on the identification tag, plus the Proof Test load as required by OSHA regulations.



Identification Tag



Certificate of Test

Basic Types of Chain Slings

Slings are designated throughout the industry by the symbols.

First Symbol (Basic Type - number of legs)

- S** Single Chain Sling with master link and hook, or hook each end.
- C** Single Choker Chain Sling with master link each end. No hooks.
- D** Double Chain Sling with standard master link and hooks.
- T** Triple Chain Sling with standard master link and hooks.
- Q** Quadruple Chain Sling with standard master link and hooks.
- SB** Single basket
- DB** Double basket

Second Symbol (Type of master link, end link or type of hook)

- O** Standard Oblong Master Link – Recommended for all types.

Third Symbol (Type of Hooks)

- S** Sling Hook
- G** Grab Hook
- CG** Cradle Grab Hook
- F** Foundry Hook
- J** Hook
- SL** Self-locking Hook

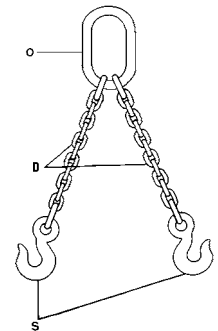

How to Order Chain Slings

1. Determine the maximum load to be lifted.
2. Refer to the following pages and choose the proper type of chain sling (single, double etc.) dictated by the size, shape and weight of the load.
3. Estimate the approximate angle between a leg of the sling and the load during operation.
4. Select the proper attachments (hooks and master links) for your chain sling.
5. Determine the overall reach from bearing point on master link to bearing point on attachment.
6. Refer to the Working Load Limit Chart and to your predetermined angle of the type sling you have selected.
7. Choose the chain size which meets your requirements.
8. When ordering, be sure you give complete information as to the size, reach and attachments required.

Note: Angle to the load on multiple leg slings will be 60° or greater as long as the distance between lifting eyes of load is not greater than reach shown on identification tag.

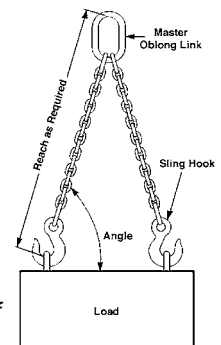



Inspection, Care and Proper Use of Chain Slings

Campbell welded chain products and components are designed and built for rugged, lasting service. As with any quality product, certain precautions and standards of treatment should be observed. Proper care will extend the useful life of the product.

INSTRUCTIONS REGARDING COMPONENTS & FITTINGS

Components, such as master links and hooks, should have at least the same working load limit (rated capacity) as the chain with which they are used. If not, the sling shall be rated to the capacity of the weakest component. Campbell offers a full line of Cam-Alloy® and Quik-Alloy® sling components engineered specifically to be compatible with our alloy chain products.

WARNINGS AND CAUTIONS

- The use of chain, slings, and components are subject to certain hazards that cannot be met by mechanical or manufacturing means, but only by the exercise of intelligence, care and common sense
- Sling use is subject to the Occupational Safety & Health Administration (OSHA 29 CFR 1910.184) and American Society for Mechanical Engineers (ASME B30.9) safety standards, requiring the sling user to conduct safe working practices and perform inspections
- Do not exceed the working load limit of the sling or any component
- Chemically active environments may adversely affect chain slings. Do not use in highly acidic or caustic environments. Campbell should be contacted if the sling will be exposed to chemically active environments during use
- High and low temperatures will affect chain slings. Campbell should be contacted if temperatures below -20°F (-29°C) will be experienced.

The Effect of Elevated Temperature on the Working Load Limit of Alloy Chain chart shows the reduction in strength that occurs when chain slings are used at or have been exposed to temperatures above 400°F (204°C)

- Never field weld or repair a chain sling. Chain slings should only be repaired by a qualified repair facility
- See information under the Care, Inspection, and Proper Use sections

INSPECTION

OSHA and ASME safety standards require the user to conduct:

a) **Frequent Inspections:** A visual inspection for damage, which should be performed each day the sling is used.

b) **Periodic Inspections:** A complete link by link and component inspection. Periodic inspection intervals vary depending on sling usage and conditions, but must occur at least annually. Written records of periodic inspections are required. The slings should be inspected for the presence damage. The sling should immediately be removed from service if any of the following conditions are present:

- Missing or unreadable identification tag
- Cracks in the chain or any component
- Excessive nicks, gouges or wear. Chain should be removed from service if the thickness at any point on the link is below the value shown in the **Cam-Alloy Chain Minimum Allowable Thickness chart**.

All other components should be removed from service if any dimension is worn more than 10% from the original dimension

- Stretched, bent, twisted, or distorted chain links or components
- Excessive corrosion
- Evidence of heat damage
- Evidence of field welding or weld spatter
- Any other condition which questions the integrity of the chain sling
- Any side movement of the Quik Alloy Coupling Link Pin could indicate excessive wear of the pin or link half and be cause for removal from service
- Depending on the severity of use and environment, individual Quik-Alloy components should be disassembled so that load pins may be thoroughly inspected

CARE

- Chain slings should be stored in a clean and dry area, preferably on a rack, in order to extend their life
- Chain slings should not be stored in areas where they would be subject to damage, corrosion, chemical attack, or extreme temperatures
- Clean slings periodically, as dust and grit can accelerate wear
- During use, chain slings should not be dragged over abrasive surfaces. Loads should not be rested on the chain sling to avoid damage

PROPER USE

To protect the operators, the load, and the sling, the following safe practices should be followed. Campbell also recommends compliance with the OSHA and ASME safety standard practices.

- Select a sling suitable for the load, type of hitch, angle of loading, and environment. The hooks and master links should be of a size to fit the intended connections

- Avoid shock loading
- Pad all sharp edges or corners in contact with the sling to prevent damage to either the sling or the load
- Balance the load to prevent shifting, to maintain control of the load, and to prevent overloading of any leg in a multiple leg sling
- Rig so that the load is properly seated in the hooks and master link. Avoid tip loading of hooks and side loading of master links
- Avoid twisting or kinking of sling legs
- Never knot chain legs

- Horizontal angles less than 30° should not be used without consulting Campbell or a qualified person
- For choker hitches, angles of choke greater than 120° should not be used without consulting Campbell or a qualified person. Choker hitches reduce the working load limit by 20% (See page 96)
- For basket hitches, the minimum recommended diameter of the load is 6 times the nominal chain diameter. The attached D/d chart shows the reduction in the WLL for D/d ratios less than 6.

Cam-Alloy Chain - Minimum Allowable Thickness

Chain Size		Cat. No. Drum	Actual Size Stock Dia.		Min. Allowable Thickness on Any	
in.	mm		in.	mm	in.	mm
$\frac{9}{32}$	7	0405212	.282	7	.239	6.07
$\frac{3}{8}$	10	0405412	.402	10	.342	8.69
$\frac{1}{2}$	13	0405512	.522	13	.443	11.26
$\frac{5}{8}$	16	0405612	.643	16	.546	13.87
$\frac{3}{4}$	20	0405712	.802	20	.687	17.45
$\frac{7}{8}$	22	0405812	.881	22	.750	19.05
1	26	0401612	1.000	25	.887	22.53
$1\frac{1}{4}$	32	0402012	1.250	32	1.091	27.71

Effect of Elevated Temperature on the Working Load Limit of Alloy Chain

Temperature (F°) (C°)		Grade of Chain			
		Grade 80 (System 8)		Grade 100 (System 10)	
		Reduction of Working Load Limit WHILE AT Temperature	Reduction of Working Load Limit AFTER EXPOSURE to Temperature	Reduction of Working Load Limit WHILE AT Temperature	Reduction of Working Load Limit AFTER EXPOSURE to Temperature
< 400°	< 204°	None	None	None	None
400°	204°	10%	None	15%	None
500°	260°	15%	None	25%	5%
600°	316°	20%	5%	30%	15%
700°	371°	30%	10%	40%	20%
800°	427°	40%	15%	50%	25%
900°	482°	50%	20%	60%	30%
1000°	538°	60%	25%	70%	35%

>1000° >538° OSHA requires that any chain sling which has experienced temperatures in excess of 1000° F be removed from service.



Cam-Alloy Chain Slings

How Lifting Angles Reduce Working Load Limits of Slings

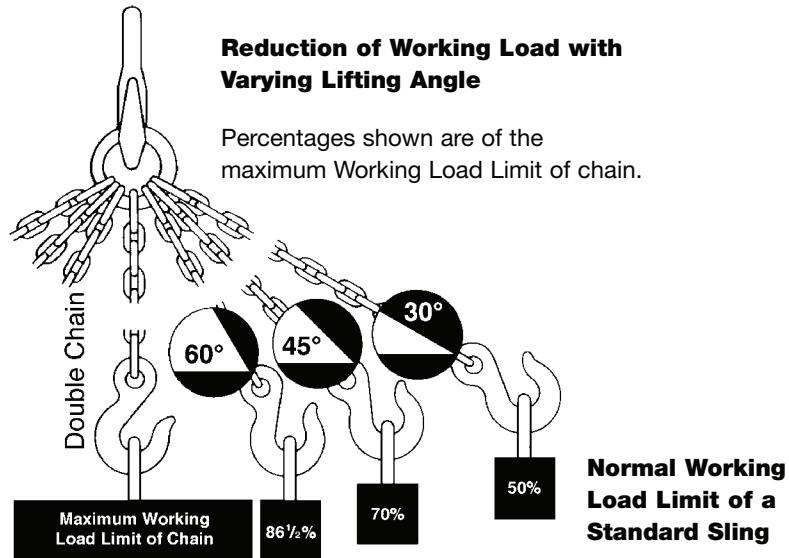

Cam-Alloy Chain Specifications

Cam-Alloy steel chain is electrically welded alloy steel embodying the latest manufacturing technology. Alloy provides a superior chain sling with high tensile strength and excellent wear resistance. The following chains meet or exceed all existing OSHA, ANSI, ASME, NACM and ASTM specification requirements.

The Cam-Alloy chain and attachments used in fabricating Campbell chain slings offer a design factor of 4 to 1. System 8 is Campbell's trade name for Grade 80 chain. System 10 is Campbell's trade name for Grade 100 chain.

Trade Size	Nominal Dimensions (in. and mm)										Drum	Working Load Limit		Feet/ Drum	Lb/ 100ft.	Links/ ft.
	Material Diameter		Inside Dimensions				Cat. No.	UPC No. 020418	lb	kg						
	in.	mm	Grade	in.	mm	Length						Width	in.			
9/32	7	100	.29	7	.86	22	.41	10	0405212	182204	4300	1950	500	74	13.8	
5/16	8	80	.32	8	.94	24	.46	12	0400512	063367	4500	2000	500	92	12.8	
5/16	8	100	.33	8	1.01	26	.50	13	0405312	245510	5700	2600	500	104	12	
3/8	10	100	.40	10	1.22	31	.57	14	0405412	182211	8800	3990	500	148	10.0	
1/2	13	100	.52	13	1.57	40	.75	19	0405512	182228	15,000	6800	300	250	7.8	
5/8	16	100	.64	16	1.93	49	.87	22	0405612	182235	22,600	10,250	200	379	6.5	
3/4	20	100	.80	20	2.42	61	1.09	28	0405712	182242	35,300	16,000	100	610	4.9	
7/8	22	100	.88	22	2.70	69	1.28	31	0405812	063497	42,700	19,400	100	775	4.4	
1	26	80	1.00	25	2.80	71	1.40	36	0401612	063510	47,700	21,600	100	965	4.3	
1 1/4	32	80	1.25	32	3.50	89	1.75	44	0402012	063534	72,300	32,800	60	1525	3.5	

The last digit of the catalog number changes to a 1 if a non-standard quantity is ordered.

NOTICE: The product specifications and dimensions are as accurate as possible at the time of printing. However, because we are constantly improving the quality and design of our product, they can change without notice.

Purchasers please note that all "Warnings and Cautions" apply to chain, components and fittings, as well as chain slings. Purchasers are responsible for conveying the "Warnings and Cautions" including the "Inspection, Care and Proper Use" section information to the end user. Campbell denies any liability for damage that results from use in excess of the working load limit or any abuse or misuse of the product. Any questions concerning the use of Campbell products may be directed to your Hillman Group Sales Representative or Customer Service.

Cam-Alloy Chain Slings Single Types: S and C

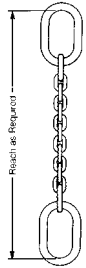

Type C0

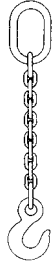

Type S0S



Type S0G



Type S0G

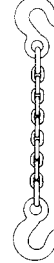

Type S0S



Type S0F



Type S0SL

Chain Size		System	Oblong Link							Working Load Limit	
			Nominal Size Material		Inside Dimensions						
			in.	mm	Width		Length		lb		
9/32	7	10	37/64	15	2 1/2	64	5	127	4,300	1,950	
3/8	10	10	13/16	21	3	76	6	152	8,800	4,000	
1/2	13	10	1 1/8	29	4	102	8	203	15,000	6,800	
5/8	16	10	1 1/8	29	4	102	8	203	22,600	10,300	
3/4	20	10	1 1/4	32	4	102	8	203	35,300	16,000	
7/8	22	10	1 5/8	41	5 1/4	133	10 1/2	267	42,700	19,400	
1	26	8	1 7/8	48	6	152	12	305	47,700	21,600	
1 1/4	32	8	2	51	7	178	14	356	72,300	32,800	

Dimensions are approximate. Single chain slings are available in other combinations. These items are made to order.

Cam-Alloy Chain Slings Double Type: D

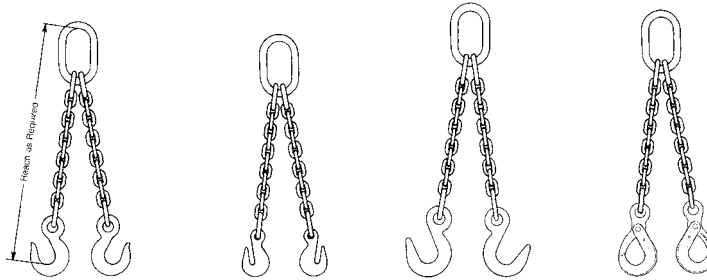

Chain Size		System	Oblong Master Link							Working Load Limit					
			Nominal Size Material		Inside Dimensions				Double at 60°		Double at 45°		Double at 30°		
			in.	mm	Width		Length		lb	kg	lb	kg	lb	kg	
9/32	7	10	37/64	15	2 1/2	64	5	127	7,400	3,400	6,100	2,700	4,300	1,950	
3/8	10	10	13/16	21	3	76	6	152	15,200	6,900	12,400	6,900	8,800	3,990	
1/2	13	10	1 1/8	29	4	102	8	203	26,000	11,800	21,200	9,600	15,000	6,800	
5/8	16	10	1 1/4	32	4	102	8	203	39,100	17,700	32,000	14,500	22,600	10,300	
3/4	20	10	1 5/8	41	5 1/4	133	10 1/2	267	61,100	27,700	49,900	22,600	35,300	16,000	
7/8	22	10	1 7/8	48	6	152	12	305	74,000	33,500	60,400	27,350	42,700	19,400	
1	26	8	2	51	7	178	14	356	82,600	37,900	67,400	31,000	47,700	21,600	
1 1/4	32	8	2 1/4	57	8	203	16	406	125,200	56,800	102,200	46,400	72,300	32,800	

Dimensions are approximate. Double chain slings are available in other combinations. These items are made to order.



Cam-Alloy Chain Slings Triple Type: T

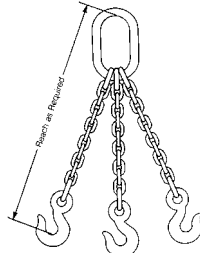

Type TOS

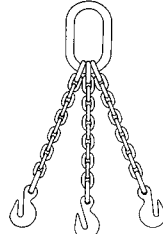

Type TOG



Type TOSL

Chain Size		System	Oblong Master Link							Working Load Limit					
			Nominal Size Material		Inside Dimensions					60°		45°		30°	
					Width		Length			Triple at 60°		Triple at 45°		Triple at 30°	
in.	mm	in.	mm	in.	mm	in.	mm	in.	mm	lb	kg	lb	kg	lb	kg
9/32	7	10	13/16	21	3	76	6	152		11,200	5,100	9,100	4,100	6,450	2,900
3/8	10	10	1 1/8	29	4	102	8	203		22,800	10,300	18,600	8,400	13,200	6,000
1/2	13	10	1 1/4	32	4	102	8	203		39,000	17,700	31,800	14,400	22,500	10,200
5/8	16	10	1 5/8	41	5 1/4	133	10 1/2	267		58,700	26,600	47,900	21,700	33,900	15,400
3/4	20	10	1 7/8	48	6	152	12	305		91,700	41,600	74,900	34,000	53,000	24,000
7/8	22	10	2 1/4	57	8	203	16	406		110,900	50,250	90,600	41,050	64,000	29,050
1	26	8	2 1/4	57	8	203	16	406		123,900	56,900	101,200	46,500	71,500	32,800
1 1/4	32	8	2 3/4	70	9	229	16	406		187,800	85,200	153,400	69,600	108,400	49,200

Dimensions are approximate. Triple chain slings are available in other combinations. These items are made to order.

Cam-Alloy Chain Slings Quadruple Type: Q

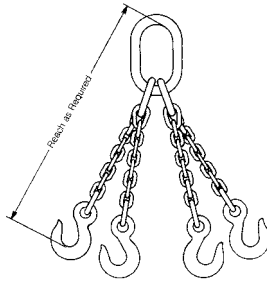

Type QOS

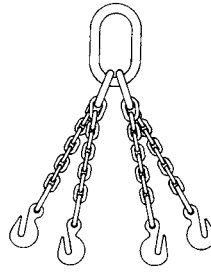

Type QOG



Type QOSL

Chain Size		System	Oblong Master Link						Master Coupling Link						Working Load Limit						
			Nominal Size Material		Inside Dimensions				Nominal Size Material		Inside Dimensions				60°		45°		30°		
					Width		Length				Width		Length		Quad at 60°		Quad at 45°		Quad at 30°		
in.	mm	in.	mm	in.	mm	in.	mm	in.	mm	in.	mm	in.	mm	in.	mm	lb	kg	lb	kg	lb	kg
9/32	7	10	13/16	21	3	76	6	152	17/32	13	1 1/2	38	2 5/8	67		11,200	5,100	9,100	4,100	6,450	2,900
3/8	10	10	1 1/8	29	4	102	8	203	25/32	20	1 5/8	41	2 7/8	73		22,800	10,300	18,600	8,400	13,200	6,000
1/2	13	10	1 1/4	32	4	102	8	203	1	25	3	76	5	127		39,000	17,700	31,800	14,400	22,500	10,200
5/8	16	10	1 5/8	41	5 1/4	133	10 1/2	267	1 1/4	32	4	102	6	152		58,700	26,600	47,900	21,700	33,900	15,400
3/4	20	10	1 7/8	48	6	152	12	305	1 1/2	38	4	102	6	152		91,700	41,600	74,900	34,000	53,000	24,000
7/8	22	10	2 1/4	57	8	203	16	406	1 3/4	44	4	102	6	152		110,900	50,250	90,600	41,050	64,000	29,050
1	26	8	2 1/4	57	8	203	16	406	1 7/8	48	5	127	7	178		123,900	56,900	101,200	46,500	71,500	32,800
1 1/4	32	8	2 3/4	70	9	229	16	406	2 1/8	54	6	152	9	229		187,800	85,200	153,400	69,600	108,400	49,200

Dimensions are approximate. Quadruple chain slings are available in other combinations. **NOTE:** In practice hooks on "Q" slings are in the plane opposite that shown.

† See Oblong Master Link Sub-Assembly for complete dimensions. These items are made to order.

Miscellaneous Cam-Alloy Chain Slings Types Single Adjustable

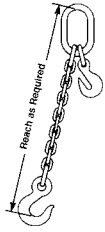

Style A



Style B

Standard with 1 foot of chain in short leg.

Chain Size	in.	mm	System	Oblong Master Link						Working Load Limit at 90°	
				Nominal Size Material		Inside Dimensions					
				in.	mm	in.	mm	Width	Length	in.	mm
9/32	7	10	37/64	15	2 1/2	64	5	127	4,300	1,950	
3/8	10	10	13/16	21	3	76	6	152	8,800	4,000	
1/2	13	10	1/8	29	4	102	8	203	15,000	6,800	
5/8	16	10	1/8	29	4	102	8	203	22,600	10,300	
3/4	20	10	1/4	32	4	102	8	203	35,300	16,000	
7/8	22	10	5/8	41	5 1/4	133	10 1/2	267	42,700	19,400	
1	26	8	1/8	48	6	152	12	305	47,700	21,600	
1 1/4	32	8	2	51	7	178	14	356	72,300	32,800	

Dimensions are approximate. These items are made to order.

Cam-Alloy Chain Slings Single Adjustable Loop

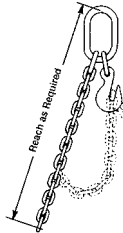

Style A

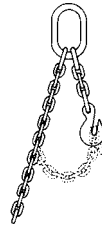

Style B

Standard with 1 foot of chain in short leg.

Chain Size	in.	mm	System	Oblong Master Link						Working Load Limit at 60°	
				Nominal Size Material		Inside Dimensions					
				in.	mm	in.	mm	Width	Length	in.	mm
9/32	7	10	37/64	15	2 1/2	64	5	127	7,400	3,400	
3/8	10	10	13/16	21	3	76	6	152	15,200	6,900	
1/2	13	10	1/8	29	4	102	8	203	26,000	11,800	
5/8	16	10	1/4	32	4	102	8	203	39,100	17,700	
3/4	20	10	5/8	41	5 1/4	133	10 1/2	267	61,100	27,700	
7/8	22	10	1/8	48	6	152	12	305	74,000	33,500	
1	26	8	2	51	7	178	14	356	82,600	37,900	
1 1/4	32	8	2 1/4	57	8	203	16	406	125,200	56,800	

For other angles of lift, refer to type "D" sling specifications. Dimensions are approximate. These items are made to order.

Cam-Alloy Chain Slings Double Adjustable

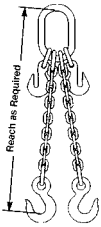

Style A



Style B

Standard with 1 foot of chain in short leg.

Chain Size	in.	mm	System	Oblong Master Link						Working Load Limit at 60°	
				Nominal Size Material		Inside Dimensions					
				in.	mm	in.	mm	Width	Length	in.	mm
9/32	7	10	37/64	15	2 1/2	64	5	127	7,400	3,400	
3/8	10	10	13/16	21	3	76	6	152	15,200	6,900	
1/2	13	10	1/8	29	4	102	8	203	26,000	11,800	
5/8	16	10	1/4	32	4	102	8	203	39,100	17,700	
3/4	20	10	5/8	41	5 1/4	133	10 1/2	267	61,100	27,700	
7/8	22	10	1/8	48	6	152	12	305	74,000	33,500	
1	26	8	2	51	7	178	14	356	82,600	37,900	

For other angles of lift, refer to type "D" sling specifications. Dimensions are approximate. These items are made to order.

Cam-Alloy Chain Slings Double Adjustable Loop

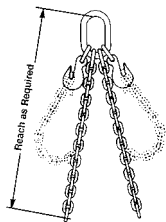

Style A

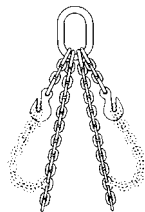

Style B

Standard with 1 foot of chain in short leg.

Chain Size	in.	mm	System	Oblong Master Link						Working Load Limit at 60°	
				Nominal Size Material		Inside Dimensions					
				in.	mm	in.	mm	Width	Length	in.	mm
9/32	7	10	13/16	21	3	76	6	152	11,200	5,100	
3/8	10	10	1/8	29	4	102	8	203	22,800	10,300	
1/2	13	10	1/4	32	4	102	8	203	39,000	17,700	
5/8	16	10	5/8	41	5 1/4	133	10 1/2	267	58,700	26,600	
3/4	20	10	1/8	48	6	152	12	305	91,700	41,600	
7/8	22	10	2 1/4	57	8	203	16	406	110,900	50,250	
1	26	8	2 1/4	57	8	203	16	406	123,900	56,900	

For other angles of lift, refer to type "D" sling specifications. Dimensions are approximate. These items are made to order.



Cam-Alloy Chain Sling Single and Double Basket

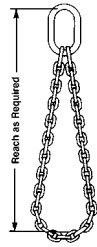

Single Basket

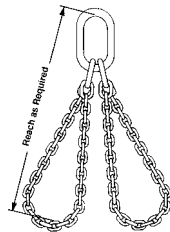

Double Basket

Chain Size	in.	mm	System	Oblong Master Link					Working Load Limit at 60°	
				Nominal Size Material		Inside Dimensions			lb	kg
				in.	mm	Width		Length		
9/32	7	10	37/64	15	2 1/2	64	5	127	7,400	3,400
3/8	10	10	13/16	21	3	76	6	152	15,200	6,900
1/2	13	10	1/8	29	4	102	8	203	26,000	11,800
5/8	16	10	1/4	32	4	102	8	203	39,100	17,700
3/4	20	10	5/8	41	5 1/4	133	10 1/2	267	61,100	27,700
7/8	22	10	1 7/8	48	6	152	12	305	74,000	33,500
1	26	8	2	51	7	178	14	356	82,600	37,900
1 1/4	32	8	2 1/4	57	8	203	16	406	125,200	56,800

Chain Size	in.	mm	System	Oblong Master Link					Working Load Limit at 60°	
				Nominal Size Material		Inside Dimensions			lb	kg
				in.	mm	Width		Length		
9/32	7	10	13/16	21	3	76	6	152	11,200	5,100
3/8	10	10	1/8	29	4	102	8	203	22,800	10,300
1/2	13	10	1/4	32	4	102	8	203	39,000	17,700
5/8	16	10	5/8	41	5 1/4	133	10 1/2	267	58,700	26,600
3/4	19	10	1 7/8	48	6	152	12	305	91,700	41,600
7/8	22	10	2 1/4	57	8	203	16	406	110,900	50,250
1	26	8	2 1/4	57	8	203	16	406	123,900	56,900

For other angles of lift, refer to Type "D" for single basket slings and Type "Q" for double basket slings. Dimensions are approximate. These items are made to order.

Cam-Alloy Chain Sling Single and Double Endless Basket



Single Endless Basket

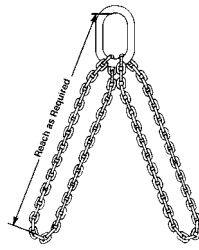

Double Endless Basket

Chain Size	in.	mm	System	Oblong Master Link					Working Load Limit at 60°	
				Nominal Size Material		Inside Dimensions			lb	kg
				in.	mm	Width		Length		
9/32	7	10	37/64	15	2 1/2	64	5	127	4,300	1,950
3/8	10	10	13/16	21	3	76	6	152	8,800	3,990
1/2	13	10	1/8	29	4	102	8	203	15,000	6,800
5/8	16	10	1/8	29	4	102	8	203	22,600	10,250
3/4	20	10	1/4	32	4	102	8	203	35,300	16,000
7/8	22	10	5/8	41	5 1/4	133	10 1/2	267	42,700	19,400
1	26	8	1 7/8	48	6	152	12	305	47,700	21,600
1 1/4	32	8	2	51	7	178	14	356	72,300	32,800

Chain Size	in.	mm	System	Oblong Master Link					Working Load Limit at 60°	
				Nominal Size Material		Inside Dimensions			lb	kg
				in.	mm	Width		Length		
9/32	7	10	13/16	21	3	76	6	152	7,400	3,400
3/8	10	10	1/8	29	4	102	8	203	15,200	6,900
1/2	13	10	1/4	32	4	102	8	203	26,000	11,800
5/8	16	10	5/8	41	5 1/4	133	10 1/2	267	39,100	17,700
3/4	20	10	1 7/8	48	6	152	12	305	61,100	27,700
7/8	22	10	2 1/4	57	8	203	16	406	74,000	33,500
1	26	8	2	51	7	178	14	356	82,600	37,900
1 1/4	32	8	2 1/4	57	8	203	16	406	125,200	56,800

For other angles of lift, refer to Type "D" for single basket slings and Type "Q" for double basket slings. Dimensions are approximate. These items are made to order.



ADVERTENCIA

Para prevenir la posibilidad de una lesión personal seria:

- **NO EXCEDA** los límites de carga de las cadenas o componentes.
- **NO LA UTILICE** para cargar hacia arriba o para izar.
- **NO LA UTILICE** si la cadena o los componentes están visualmente distorsionados o gastados.



WARNING

To prevent the possibility of serious bodily injury:

- **DO NOT EXCEED** the working load limits for chain or components.
- **DO NOT USE** for overhead lifting or hoisting.
- **DO NOT USE** if the chain or components are visibly distorted or worn.

Cam-Alloy Chain Slings Double with Links Only

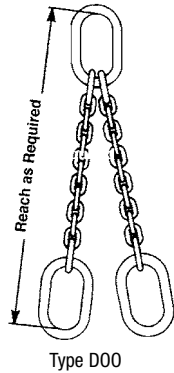

Chain Size	in.	mm	System	Oblong Master Link						Standard Oblong Link						Working Load Limit at 60°	
				Nominal Size Material		Inside Dimensions				Nominal Size Material		Inside Dimensions					
				in.	mm	Width		Length		in.	mm	Width		Length			
9/32	7	10	10	37/64	15	2 1/2	64	5	127	37/64	15	2 1/2	64	5	127	7,400	3,400
3/8	10	10	10	13/16	21	3	76	6	152	13/16	21	3	76	6	152	15,200	6,900
1/2	13	10	10	1 1/8	29	4	102	8	203	1 1/8	29	4	102	8	203	26,000	11,800
5/8	16	10	10	1 1/4	32	4	102	8	203	1 1/8	29	4	102	8	203	39,100	17,700
3/4	20	10	10	1 5/8	41	5 1/4	133	10 1/2	267	1 1/4	32	4	102	8	203	61,100	27,700
7/8	22	10	10	1 7/8	48	6	152	12	305	1 1/2	38	5 1/4	133	10 1/2	267	74,000	33,500
1	26	8	8	2	51	7	178	14	356	1 3/4	44	6	152	12	305	82,600	37,900
1 1/4	32	8	8	2 1/4	57	8	203	16	406	2	51	7	178	14	356	125,200	56,800

Dimensions and weights are approximate. For other angles of lift, refer to Type "D" slings. These items are made to order.

Cam-Alloy Chain Shortener

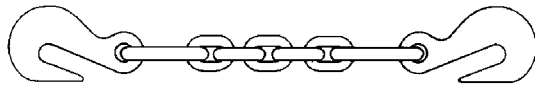

Chain Size	in.	mm	System	Reach	Working Load Limit	
					lb	kg
9/32	7	10	10	1'1"	4,300	1,950
3/8	10	10	10	1'3"	8,800	4,000
1/2	13	10	10	1'8"	15,000	6,800
5/8	16	10	10	2'0"	22,600	10,300
3/4	20	10	10	2'4"	35,300	16,000
7/8	22	10	10	2'8"	42,700	19,400
1	26	8	8	3'1"	47,700	21,600
1 1/4	32	8	8	3'10"	72,300	32,800

Dimensions are approximate. These items are made to order.

Cam-Alloy Chain Slings Attachment, One End Only

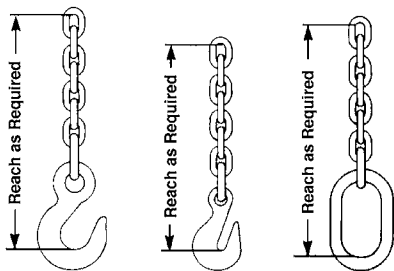

Chain Size	in.	mm	System	Working Load Limit	
				lb	kg
9/32	7	10	10	4,300	1,950
3/8	10	10	10	8,800	4,000
1/2	13	10	10	15,000	6,800
5/8	16	10	10	22,600	10,300
3/4	20	10	10	35,300	16,000
7/8	22	10	10	42,700	19,400
1	26	8	8	47,700	21,600
1 1/4	32	8	8	72,300	32,800

Dimensions are approximate. These items are made to order.

How Off-Center (Tip) Loading Reduces Working Load Limits of 1/2" - Cam-Alloy Sling Hooks

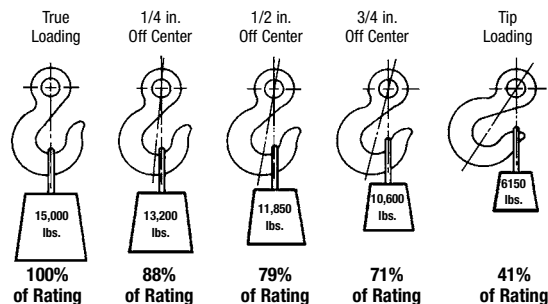



Cam-Alloy Sling Hooks

- For Use with Grade 80/100 Chain Slings
- 4 to 1 Design Factor
- Meet or Exceed All Requirements of ASME B30.9 and B30.10
- 100% Proof Tested in Accordance with ASTM A952
- Additionally Hallmarked with "USA" and Date Code
- Made in the USA
- DO NOT EXCEED THE WORKING LOAD LIMIT

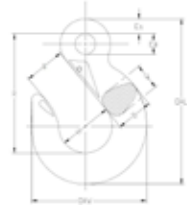

Chain Size	Cat. No.	UPC No.	Grade	Working Load Limit	Weight Each	Replacement Latch No.
9/32 in, 5/16 in	5646415PL	020418319167	100	5700 lb	1.61 lb	7506495PL
3/8 in	5646615PL	020418319181	100	8800 lb	3.31 lb	7506695PL
1/2 in	5646815PL	020418319204	100	15000 lb	6.52 lb	7506895PL
5/8 in	5647015PL	020418319228	100	22600 lb	11.05 lb	7507095PL
3/4 in	5647215PL	020418319235	100	35300 lb	15.100 lb	7507295PL

Chain Size	Cat. No.	D Dim.	Ed Dim.	Es Dim.	H Dim.	OAL	OAW	R Dim.	S Dim.	W Dim.
9/32 in, 5/16 in	5646415PL	1-11/32 in	3/4 in	15/32 in	1-1/2 in	6 in	3-25/32 in	4-11/32 in	1-11/32 in	7/8 in
3/8 in	5646615PL	1-9/16 in	13/16 in	19/32 in	2-1/8 in	7 in	4-23/32 in	5-3/32 in	1-21/32 in	1-5/16 in
1/2 in	5646815PL	2-3/32 in	1-1/8 in	3/4 in	2-7/16 in	8-25/32 in	5-31/32 in	6-7/32 in	1-15/16 in	1-7/16 in
5/8 in	5647015PL	2-19/32 in	1-5/16 in	7/8 in	2-13/16 in	10-3/4 in	7-1/8 in	7-23/32 in	2-7/16 in	1-3/4 in
3/4 in	5647215PL	3-3/32 in	1-1/2 in	1 in	3-1/8 in	12 in	8-17/32 in	8-9/32 in	2-21/32 in	2-3/32 in

Cam-Alloy Sling Hooks with Latches

- For Use with Grade 80/100 Chain Slings
- 4 to 1 Design Factor
- Meet or Exceed All Requirements of ASME B30.9 and B30.10
- 100% Proof Tested in Accordance with ASTM A952
- Additionally Hallmarked with "USA" and Date Code
- Integrated Latch Engages Tip of Hook
- Made in the USA
- DO NOT EXCEED THE WORKING LOAD LIMIT

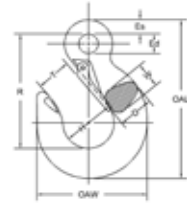

Chain Size	Cat. No.	UPC No.	Grade	Working Load Limit	Weight Each	Replacement Latch No.
9/32 in, 5/16 in	5646495PL	020418319174	100	5700 lb	1.67 lb	7506495PL
3/8 in	5646695PL	020418319198	100	8800 lb	3.41 lb	7506695PL
1/2 in	5646895PL	020418319211	100	15000 lb	6.68 lb	7506895PL

Chain Size	Cat. No.	D Dim.	Ed Dim.	Es Dim.	H Dim.	OAL	OAW	R Dim.	T Dim.	W Dim.
9/32 in, 5/16 in	5646495PL	1-11/32 in	3/4 in	15/32 in	1-1/2 in	6 in	3-25/32 in	4-11/32 in	1-5/32 in	7/8 in
3/8 in	5646695PL	1-9/16 in	13/16 in	19/32 in	2-1/8 in	7 in	4-23/32 in	5-3/32 in	1-15/32 in	1-5/16 in
1/2 in	5646895PL	2-3/32 in	1-1/8 in	3/4 in	2-7/16 in	8-25/32 in	5-31/32 in	6-7/32 in	1-11/16 in	1-7/16 in

Sling Hook Replacement Latches (IL Style)

- Replacement Latches for Cam-Alloy & Quik-Alloy Sling Hooks
- Latch Design Fits Integrated Tip Sling Hooks



Trade Size	Cat. No.	UPC No.	Cam-Alloy Sling Hook	Cam-Alloy Sling Hook with Latch	Quik-Alloy Sling Hook	Quik-Alloy Sling Hook with Latch	Latch Marking	Weight Each
9/32 in	7506495	020418223853	5646415	5646495	5746415	5746495	CC-4	0.08 lb
3/8 in	7506695	020418223846	5646615	5646695	5746615	5746695	CC-5	0.08 lb
1/2 in	7506895	020418225161	5646815	5646895	5746815	5746895	CC-7	0.14 lb
5/8 in	7507095	020418225178	5647015	-	5747015	5747095	CC-8	0.18 lb
3/4 in	7507295	020418225154	5647215	-	5747215	5747295	CC-9	0.52 lb

Cam-Alloy Foundry Hooks

- For Use with Grade 80/100 Chain Slings
- 4 to 1 Design Factor
- Meet or Exceed All Requirements of ASME B30.9 and B30.10
- 100% Proof Tested in Accordance with ASTM A952
- Additionally Hallmarked with "USA" and Date Code
- Made in the USA
- DO NOT EXCEED THE WORKING LOAD LIMIT

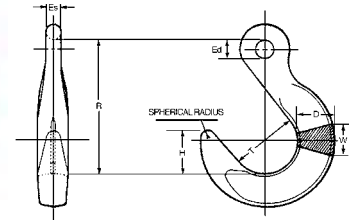

Chain Size	Cat. No.	UPC No.	Hook No.	Grade	Working Load Limit	Weight Each	Spherical Radius	D Dim.	Ed Dim.	Es Dim.	H Dim.	R Dim.	T Dim.	W Dim.
9/32 in	5664415	020418182457	C-498	100	4300 lb	2.20 lb	0.25 in	1.3 in	0.62 in	0.47 in	1.56 in	4.75 in	2.50 in	1.00 in
3/8 in	5664615	020418182464	C-499	100	8800 lb	3.90 lb	0.31 in	1.56 in	0.75 in	0.62 in	1.87 in	5.75 in	3.00 in	1.25 in
1/2 in	5664815	020418182471	C-500	100	15000 lb	6.70 lb	0.37 in	1.81 in	1.00 in	0.75 in	2.25 in	6.87 in	3.50 in	1.50 in
5/8 in	5665015	020418182488	C-501	100	22600 lb	10.50 lb	0.44 in	2.33 in	1.25 in	0.87 in	2.62 in	8.06 in	4.00 in	1.75 in
3/4 in	5665215	020418182495	C-502	100	35300 lb	15.60 lb	0.50 in	2.81 in	1.50 in	1.00 in	3.00 in	9.25 in	4.50 in	2.00 in
7/8 in	5665415	020418152948	C-503	100	42700 lb	24.00 lb	0.56 in	3.08 in	1.84 in	1.12 in	3.37 in	10.37 in	5.00 in	2.25 in
1 in	5661615	020418078965	C-504	80	47700 lb	34.10 lb	0.62 in	3.25 in	2.09 in	1.25 in	3.75 in	11.56 in	5.50 in	2.50 in
1-1/4 in	5662015	020418078972	C-505	80	72300 lb	52.50 lb	0.75 in	3.88 in	2.47 in	1.37 in	4.25 in	12.87 in	6.00 in	3.00 in



Cam-Alloy Grab Hooks

- For Use with Grade 80/100 Chain Slings
- 4 to 1 Design Factor
- Meet or Exceed All Requirements of ASME B30.9 and B30.10
- 100% Proof Tested in Accordance with ASTM A952
- Additionally Hallmarked with "USA" and Date Code
- Made in the USA
- Note: Use of Chain in a Grab Hook as a Shortening Application May Result in a 20% WLL Reduction
- DO NOT EXCEED THE WORKING LOAD LIMIT

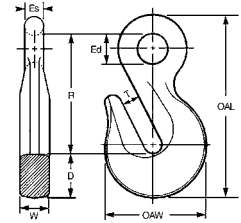

Chain Size	Cat. No.	UPC No.	Hook No.	Grade	Working Load Limit	D Dim.	Ed Dim.	Es Dim.	OAL	OAW	R Dim.	T Dim.	W Dim.	Weight Each	Shelf Pack
9/32 in	5624415	020418182303	C-72	100	4300 lb	0.81 in	0.56 in	0.37 in	3.69 in	1.87 in	2.50 in	0.37 in	0.59 in	0.60 lb	50
3/8 in	5624615	020418182310	C-73	100	8800 lb	1.16 in	0.75 in	0.44 in	4.00 in	2.56 in	2.41 in	0.50 in	0.66 in	0.90 lb	30
1/2 in	5624815	020418182327	C-75	100	15000 lb	1.44 in	1.12 in	0.56 in	5.40 in	3.50 in	3.40 in	0.66 in	0.88 in	2.80 lb	20
5/8 in	T5625015	020418182334	C-76	100	22600 lb	1.75 in	1.22 in	0.69 in	6.66 in	4.25 in	4.22 in	0.78 in	1.12 in	3.70 lb	-
3/4 in	5625215	020418182341	C-77	100	35300 lb	2.12 in	1.44 in	1.00 in	8.28 in	5.18 in	5.15 in	0.94 in	1.38 in	7.50 lb	-
7/8 in	T5625415	020418152979	C-78	100	42700 lb	2.44 in	1.75 in	1.00 in	10.44 in	5.68 in	7.00 in	1.06 in	1.62 in	11.20 lb	-

Self-Locking Eye Hooks

- Meet or Exceed All Requirements of ASME B30.9 and B30.10
- Fatigue and 100% Proof Tested in Accordance with ASTM A952
- Additionally Hallmarked with "USA" and Date Code
- Meets the Intent of OSHA Regulation 1926.550(g)(4)(iv)(b)
- Latch Closes Automatically Under Load
- Eye Style is Designed to Accommodate Heavy Duty Wire Rope Thimbles
- Stamped with Recommended Wire Rope Size
- Working Load Limit Rating of 5 to 1 to Meet Design Requirements of Wire Rope Slings
- Made in the USA
- DO NOT EXCEED THE WORKING LOAD LIMIT

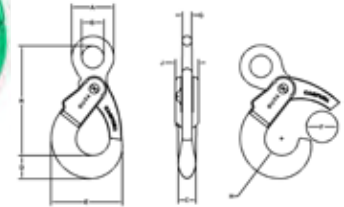

Chain Size	Cat. No.	UPC No.	Working Load Limit 4 to 1	For Wire Rope Size	Working Load Limit 5 to 1	Weight Each	Shelf Pack
9/32 in	5648495	020418193262	4300 lb	7/16 in	3800 lb	2.25 lb	-
3/8 in	5648695	020418193279	8800 lb	1/2 in	7000 lb	4.00 lb	-
1/2 in	5648895	020418193286	15000 lb	5/8 in	12000 lb	8.65 lb	1
5/8 in	5649095	020418193293	22600 lb	7/8 in	18000 lb	13.80 lb	1

Chain Size	Cat. No.	A Dim.	B Dim.	C Dim.	D Dim.	E Dim.	F Dim.	G Dim.	H Dim.	J Dim.	R Dim.
9/32 in	5648495	1.875 in	1.00 in	0.938 in	1.02 in	3.594 in	1.625 in	0.438 in	0.875 in	1.25 in	5.468 in
3/8 in	5648695	2.375 in	1.375 in	1.125 in	1.250 in	4.312 in	1.875 in	0.578 in	1.063 in	1.50 in	6.50 in
1/2 in	5648895	3.188 in	1.688 in	1.312 in	1.796 in	5.404 in	2.250 in	0.688 in	1.281 in	1.75 in	8.75 in
5/8 in	5649095	3.50 in	2.00 in	1.50 in	2.169 in	6.50 in	2.375 in	0.75 in	1.50 in	2.00 in	10.00 in

Self-Locking Swivel Hooks

- Meet or Exceed All Requirements of ASME B30.9 and B30.10
- Fatigue and 100% Proof Tested in Accordance with ASTM A952
- Additionally Hallmarked with "USA" and Date Code
- Meets the Intent of OSHA Regulation 1926.550(g)(4)(iv)(b)
- Latch Closes Automatically Under Load
- Working Load Limit Rating of 5 to 1 to Meet Design Requirements of Wire Rope Slings
- Made in the USA
- DO NOT EXCEED THE WORKING LOAD LIMIT
- HOOK IS NOT DESIGNED TO SWIVEL UNDER LOAD

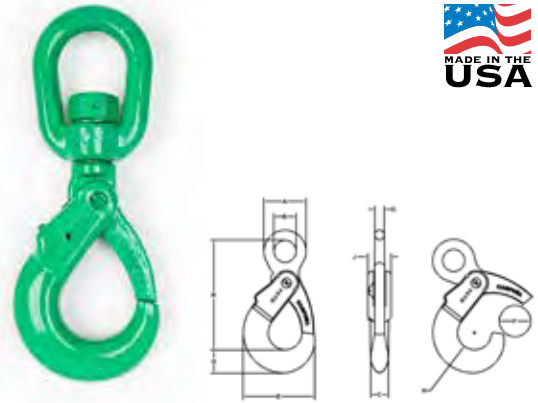

Chain Size	Cat. No.	UPC No.	Working Load Limit 4 to 1	For Wire Rope Size	Working Load Limit 5 to 1	Weight Each
9/32 in	5798495	020418226830	4300 lb	7/16 in	3800 lb	3.35 lb
3/8 in	5798695	020418226847	8800 lb	1/2 in	7000 lb	5.80 lb
1/2 in	5798895	020418226878	15000 lb	5/8 in	12000 lb	12.95 lb
5/8 in	5799095	020418226861	22600 lb	7/8 in	18000 lb	21.00 lb

Chain Size	Cat. No.	A Dim.	B Dim.	C Dim.	D Dim.	E Dim.	F Dim.	G Dim.	H Dim.	J Dim.	R Dim.
9/32 in	5798495	3.00 in	1.75 in	0.938 in	1.02 in	3.594 in	1.625 in	0.625 in	0.875 in	1.25 in	7.688 in
3/8 in	5798695	3.50 in	2.00 in	1.125 in	1.25 in	4.312 in	1.875 in	0.75 in	1.063 in	1.50 in	8.813 in
1/2 in	5798895	4.50 in	2.50 in	1.312 in	1.796 in	5.404 in	2.25 in	1.00 in	1.281 in	1.75 in	11.25 in
5/8 in	5799095	5.625 in	3.50 in	1.50 in	2.169 in	6.50 in	2.375 in	1.25 in	1.50 in	2.00 in	13.438 in

Self-Locking Hook Repair Kits

- Trigger Repair Kit for Clevis, Eye and Swivel Self Locking Hooks
- Repair Kit Contents:
 - Pivot Pin
 - Drive Pins (2)
 - Trigger
 - Trigger Spring
 - Spring Alignment Insert (9/32 & 3/8 Kits Only)



Hook Size	Cat. No.	UPC No.	Weight Each (lb)
9/32 in	5788495	020418207518	0.10 lb
3/8 in	5788695	020418207525	0.20 lb
1/2 in	5788895	020418210600	1.00 lb
5/8 in	5789095	020418211874	0.55 lb

SLINGS



Cam-Alloy Oblong Master Links

- For Use with Grade 80/100 Chain Slings, Wire Rope and Synthetic Assemblies
- 5 to 1 Design Factor
- Meet or Exceed All Requirements of ASME B30.26
- 100% Proof Tested in Accordance with ASTM A952
- Hallmarked with "USA", Date Code, Link No. and Material Diameter
- Made in the USA
- DO NOT EXCEED THE WORKING LOAD LIMIT

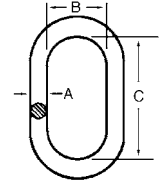

Link Number	Cat. No.	UPC No.	Material Diameter (A)	Inside Width (B)	Inside Length (C)	WLL 5 to 1	Used w/ Single Type S & C	Used with Double Type D	Used w/Triple or Quad Type T or Q	Weight Each
CO-0	5685615	020418079214	13/32 in	1.50 in	3.00 in	4200 lb	7/32 in	7/32 in		0.50 lb
CO-1	5683215	020418182549	5/8 in	2.50 in	5.00 in	8600 lb	9/32 in	9/32 in	7/32 in	1.10 lb
CO-2	5683315	020418182556	13/16 in	3.00 in	6.00 in	17600 lb	3/8 in	3/8 in	9/32 in	2.63 lb
CO-3	5683415	020418182563	1-1/8 in	4.00 in	8.00 in	30000 lb	1/2 in or 5/8 in	1/2 in	3/8 in	8.00 lb
CO-4	5683515	020418182570	1-1/4 in	4.00 in	8.00 in	45200 lb	3/4 in	5/8 in	1/2 in	9.20 lb
CO-5	5683615	020418182587	1-5/8 in	5.25 in	10.50 in	70600 lb	7/8 in	3/4 in	5/8 in	18.90 lb
CO-6	5683715	020418182594	1-7/8 in	6.00 in	12.00 in	105900 lb	1 in	7/8 in	3/4 in	28.71 lb
CO-7	5687015	020418079351	2 in	7.00 in	14.00 in	102600 lb	1-1/4 in or 1-1/2 in	1 in		37.30 lb
CO-8	5687215	020418079375	2-1/4 in	8.00 in	16.00 in	144600 lb	-	1-1/4 in or 1-1/2 in	7/8 in or 1 in	54.00 lb

Cam-Alloy Wide Master Oblong Links

- Wider Than Standard Master Links
- Usable with Quik-Alloy® Coupling Links for Double Leg Slings
- Wider Link Accommodates Heavy Wire Rope Thimbles in Multiple Leg Slings
- Grade 100 Chain Strength
- 5 to 1 Design Factor
- Meet or Exceed All Requirements of ASME B30.26
- 100% Proof Tested in Accordance with ASTM A952
- Hallmarked with "USA", Date Code, Link No. and Material Diameter
- Made in the USA
- DO NOT EXCEED THE WORKING LOAD LIMIT

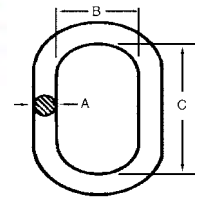

Link Number	Cat. No.	UPC No.	Material Diameter (A)	Inside Width (B)	Inside Length (C)	Working Load Limit 5 to 1	Shelf Pack	Weight Each
CW-2	5683315VW	020418239496	7/8 in	4.00 in	6.50 in	17600 lb	1	3.50 lb
CW-3	5683415VW	020418239502	1-1/8 in	4.25 in	7.50 in	30000 lb	1	6.55 lb
CW-4	5683515VW	020418239519	1-3/8 in	5.50 in	9.50 in	45200 lb	1	12.60 lb
CW-5	5683615VW	020418239489	1-5/8 in	5.875 in	10.50 in	70600 lb	1	19.20 lb

Cam-Alloy Oblong, Master Link Sub-Assemblies

- For Construction of Triple, Quad and Double Basket Slings
- 5 to 1 Design Factor
- Meet or Exceed All Requirements of ASME B30.26
- 100% Proof Tested in Accordance with ASTM A952
- Master Link Hallmarked with "USA", Date Code, Link No. and Material Diameter
- Made in the USA
- DO NOT EXCEED THE WORKING LOAD LIMIT

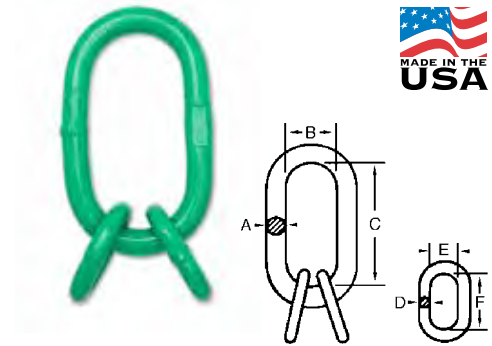

Chain Size	Cat. No.	UPC No.	WLL 5 to 1	Master Link Dim (A)	Master Link Dim (B)	Master Link Dim (C)	Master Coupling Link Dim (D)	Master Coupling Link Dim (E)	Master Coupling Link Dim (F)	Weight Each
9/32 in	5682215	020418182501	12900 lb	13/16 in	3 in	6 in	17/32 in	1-1/2 in	2-3/4 in	4.40 lb
3/8 in	5682315	020418182846	26400 lb	1-1/8 in	4 in	8 in	25/32 in	1-9/16 in	2-7/8 in	9.50 lb
1/2 in	5682415	020418182518	45000 lb	1-1/4 in	4 in	8 in	1 in	3 in	5 in	16.00 lb
5/8 in	5682515	020418182525	67800 lb	1-5/8 in	5-1/4 in	10-1/2 in	1-1/4 in	4 in	6 in	31.75 lb
3/4 in	5682615	020418182532	105900 lb	1-7/8 in	6 in	12 in	1-1/2 in	4 in	6 in	50.00 lb
7/8 in	5682715	020418167409	128100 lb	2-1/4 in	8 in	16 in	1-3/4 in	4 in	6 in	85.00 lb



Quik-Alloy Chain Slings

The Campbell Quik-Alloy system provides proof tested and certified components for easily and quickly assembling all of the popular types of chain slings plus many special slings.

Hooks and coupling links have rotating load pins that resist bending and offer shear values equivalent to the chain. The open design of the hooks allows for easy inspection. All Quik-Alloy components are sized and identified according to the chain with which they are to be used. They meet or exceed all OSHA, ANSI, and ASME specifications.

How to Design Quik-Alloy Chain Slings

1. Determine the maximum LOAD to be lifted.
2. Choose the TYPE of sling assembly necessitated by the size and dimension of the load.
3. Estimate the approximate ANGLE to the load in which the legs of the assembly will be positioned for operation.
4. Determine the SIZE OF CHAIN ATTACHMENTS by referring to the Assembly Tables that follow. On multi-leg slings, if the distance between the points of attachment equals the reach of the sling, the angle is approximately 60°
5. Determine the overall REACH (see illustration). Use the Assembly Tables that follow to determine length of Cam-Alloy chain to order.
6. Attach field identification tag to all slings.
One box of 50 - No. 7503506.

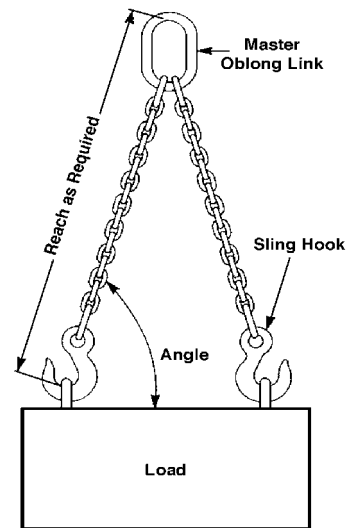

For any problem involving reach, angle of lift or working load limit, consult your local Campbell distributor. Remember to use only Campbell "Quik-Alloy" components in assembling chain slings.

SUBSTITUTION OF ANY COMPONENTS WITH PARTS NOT INDICATED ON THE CHART COULD SERIOUSLY DIMINISH THE WORKING LOAD OF THE ASSEMBLY. Do not use any coupling links to repair damaged or broken chain. It is imperative that such chain be replaced.

How to Assemble Quik-Alloy Coupling Links

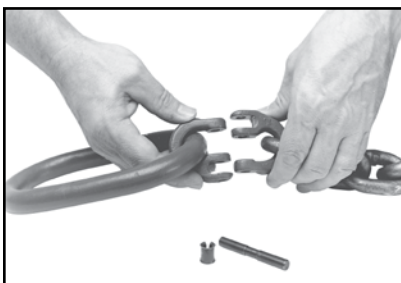

1. Loop one half of body over the master link at the flat embossed area, the other half through the chain. Fit together.



2. Place stud assembly and alloy locking pin in link as shown.



3. Drive the locking pin in until the snap ring engages the recessed portion of the pin. (Link is disassembled by simply driving locking pin out.)

How to Use Quik-Alloy Chain Sling Assembly Tables

If the overall reach of your sling is determined to be more than five feet, subtract five feet, then add this difference to the “chain needed” length on the Assembly Table. If overall reach is less than five feet, subtract reach from five feet. Then subtract the difference from the “chain needed” length in the Assembly Table. All measurements are based on using Quik-Alloy hooks (not Cam-Alloy).

WHEN USING QUIK-ALLOY HOOKS (NOT CAM-ALLOY HOOKS), BE SURE THAT EACH LEG OF A DOUBLE SLING HAS THE SAME, EVEN (DIVISIBLE BY TWO) NUMBER OF LINKS. For triple or quad slings, each leg should have odd numbers of links to compensate for coupling links on master link sub-assembly. When cutting, if the required reach falls within a link, LEAVE THAT LINK. Reach measurements are given as a minimum. Never cut less than specified reach.

Quik-Alloy Chain Sling Assembly Tables

Chain Size	in.	mm	in.	mm	in.	mm	in.	mm	in.	mm
	9/32	7	3/8	10	1/2	13	5/8	16	3/4	19

Single Chain Slings: Types S and C

Working Load Limit		lb	kg	lb	kg	lb	kg	lb	kg	lb	kg
		4,300	1,952	8,800	3,995	15,000	6,810	22,600	10,260	35,300	16,026
Master Link Number		CO-1		CO-2		CO-3		CO-3		CO-4	
Cat.No.	Master Link	5683215		5683315		5683415		5683515		5683615	
	QA Sling Hook	5746415		5746615		5746815		5747015		5747015	
	QA Grab Hook	5724415		5724615		5724815		5725015		5725215	
	QA Cradle Grab Hook	5726415		5726615		5726815		5727015			
	QA Coupling Link	5779225		5779235		5779245		5779255		5779165	
Chain needed for 5' reach	Sling Hook	4'1"		3'10"		3'7"		3'5"		3'3"	
	Grab Hook	4'3"		4'0"		3'9"		3'8"		3'6"	

Double Chain Slings: Type D

Working Load Limit		lb	kg	lb	kg	lb	kg	lb	kg	lb	kg
60°		7,500	3,405	15,200	6,901	26,000	77,804	39,100	17,751	61,100	27,739
45°		6,100	2,769	12,400	5,630	21,200	9,625	32,000	14,528	49,900	22,655
30°		4,300	1,952	8,800	3,995	15,000	6,810	22,600	10,260	35,300	16,026
Master Link Number		CO-1		CO-2		CO-3		CO-4		CO-5	
Cat.No.	Master Link	5683215		5683315		5683415		5683515		5683615	
	QA Sling Hook	5746415		5746615		5746815		5747015		5747015	
	QA Grab Hook	5724415		5724615		5724815		5725015		5725215	
	QA Cradle Grab Hook	5726415		5726615		5726815		5727015			
	QA Coupling Link	5779225		5779235		5779245		5779255		5779165	
Chain needed for 5' reach	Sling Hook	4'1"		3'10"		3'7"		3'5"		3'1"	
	Grab Hook	4'3"		4'0"		3'9"		3'8"		3'3"	

Triple Chain Slings: Type T and Quad Chain Slings: Type Q

Working Load Limit		lb	kg	lb	kg	lb	kg	lb	kg	lb	kg
60°		11,200	5,085	22,800	10,351	39,000	17,706	58,700	26,650	91,700	41,632
45°		9,100	4,131	18,600	8,444	31,800	14,437	47,900	21,747	74,900	34,005
30°		6,450	2,928	13,200	5,993	22,500	10,215	33,900	15,391	53,000	24,062
Master Link Number		CO-2		CO-3		CO-4		CO-5		CO-6	
Cat.No.	Sub-Assembly	5682215		5682315		5682415		5682515		5682615	
	QA Sling Hook	5746415		5746615		5746815		5747015		5747015	
	QA Grab Hook	5724415		5724615		5724815		5725015		5725215	
	QA Cradle Grab Hook	5726415		5726615		5726815		5727015			
	QA Coupling Link	5779225		5779235		5779245		5779255		5779165	
Chain needed for 5' reach	Sling Hook	3'10"		3'6"		3'2"		2'10"		2'5"	
	Grab Hook	3'11"		3'8"		3'4"		2'10"		2'8"	



Quik-Alloy Coupling Links

- For Connecting Chain to Components in the Fabrication of Chain Slings
- For Use with Grade 80/100 Chain Slings
- 4 to 1 Design Factor
- Meet or Exceed All Requirements of ASME B30.9
- 100% Proof Tested in Accordance with ASTM A952
- 3/4" Through 1-1/4" Coupling Links Utilize A Barrel Style Oversized Retainer
- Made in the USA
- Per ASME B30.9, Section 9.1.3 "Mechanical Coupling Links Shall Not Be Used Within the Body of An Alloy Chain Sling to Connect Two Pieces of Chain"
- DO NOT EXCEED THE WORKING LOAD LIMIT

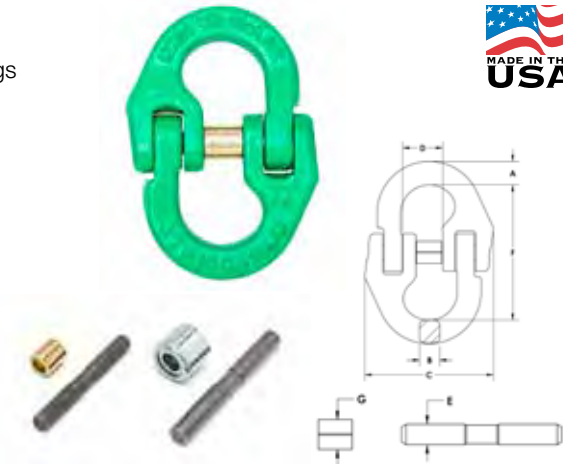

Chain Size	Cat. No.	UPC No.	Grade	Material Diameter	WLL	A Dim.	B Dim.	C Dim.	D Dim.	E Dim.	F Dim.	G Dim.	Weight Each
9/32 in	5779225	020418288890	100	45/64 in	4300 lb	3/8 in	11/32 in	23/32 in	9/16 in	13/64 in	2-13/64 in	5/16 in	0.26 lb
3/8 in	5779235	020418288623	100	15/16 in	8800 lb	1/2 in	7/16 in	2-3/8 in	13/16 in	5/16 in	2-3/4 in	7/16 in	0.69 lb
1/2 in	5779245	020418288913	100	1-1/8 in	15000 lb	11/16 in	9/16 in	3 in	1-1/32 in	25/64 in	3-3/8 in	5/8 in	1.56 lb
5/8 in	5779255	020418288937	100	1-3/8 in	22600 lb	13/16 in	23/32 in	3-7/8 in	1-9/32 in	15/32 in	4-1/8 in	11/16 in	2.51 lb
3/4 in	5779165	020418182785	100	1-5/8 in	35300 lb	15/16 in	61/64 in	4-5/8 in	1-9/16 in	9/16 in	4-3/4 in	-	4.05 lb
7/8 in	5779175	020418152931	100	1-13/16 in	42700 lb	1-3/16 in	1-1/16 in	5-3/8 in	1-13/16 in	41/64 in	5-5/16 in	-	8.00 lb
1 in	5771615	020418080067	80	2 in	47700 lb	1-15/64 in	1-9/64 in	5-7/8 in	2-1/32 in	11/16 in	5-7/8 in	-	9.50 lb
1-1/4 in	5772015	020418080074	80	2-3/8 in	72300 lb	1-1/2 in	1-3/8 in	7-3/8 in	2-9/32 in	15/16 in	6-15/16 in	-	16.62 lb

Quik-Alloy Coupling Link Pins and Retainers

- Replacement Pins and Retainers for Quik-Alloy Coupling Links
- Made in the USA



Chain Size	Cat. No.	UPC No.	Grade	Weight Each	Shelf Pack
9/32 in	5785425	020418288906	100	0.02 lb	10
3/8 in	5785435	020418288630	100	0.06 lb	10
1/2 in	5785445	020418288920	100	0.11 lb	10
5/8 in	5785455	020418288944	100	0.17 lb	5
3/4 in	5784465	020418182839	100	0.35 lb	5
7/8 in	5784165	020418181740	100	0.58 lb	-

Quik-Alloy Sling Hooks, Regular

- For Use with Grade 80/100 Chain Slings
- 4 to 1 Design Factor
- Meet or Exceed All Requirements of ASME B30.9 and B30.10
- 100% Proof Tested in Accordance with ASTM A952
- Additionally Hallmarked with "USA" and Date Code
- Made in the USA
- DO NOT EXCEED THE WORKING LOAD LIMIT

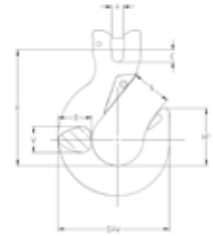

Chain Size	Cat. No.	UPC No.	Grade	Working Load Limit	Replacement Latch No.	Load Pin Diameter	Weight Each
9/32 in, 5/16 in	5746415PL	020418319242	100	5700 lb	7506495PL	3/8 in	1.80 lb
3/8 in	5746615PL	020418319266	100	8800 lb	7506695PL	1/2 in	3.56 lb
1/2 in	5746815PL	020418319297	100	15000 lb	7506895PL	5/8 in	7.10 lb
5/8 in	5747015PL	020418319310	100	22600 lb	7507095PL	3/4 in	11.08 lb
3/4 in	5747215PL	020418319334	100	35300 lb	7507295PL	15/16 in	18.17 lb

Chain Size	Cat. No.	A Dim.	D Dim.	E Dim.	HP	OAL	OAW	R Dim.	S Dim.	T Dim.	W Dim.
9/32 in, 5/16 in	5746415PL	23/64 in	1-11/32 in	23/64 in	1-23/32 in	5-57/64 in	3-13/16 in	4-1/32 in	1-11/32 in	1-11/64 in	27/32 in
3/8 in	5746615PL	1/2 in	1-37/64 in	13/32 in	2-3/8 in	7-15/64 in	4-23/32 in	5-1/16 in	1-21/32 in	1-15/32 in	1-5/16 in
1/2 in	5746815PL	39/64 in	2-7/64 in	5/8 in	2-61/64 in	9-3/32 in	5-61/64 in	6-7/32 in	1-15/16 in	1-11/16 in	1-3/8 in
5/8 in	5747015PL	47/64 in	2-37/64 in	3/4 in	3-21/64 in	10-31/64 in	7-5/32 in	7-5/32 in	2-7/16 in	2-5/64 in	1-3/4 in
3/4 in	5747215PL	55/64 in	3-3/32 in	57/64 in	3-49/64 in	11-63/64 in	8-9/16 in	7-21/32 in	2-43/64 in	2-23/64 in	2-1/16 in

Quik-Alloy Sling Hooks, Latched

- For Use with Grade 80/100 Chain Slings
- 4 to 1 Design Factor
- Meet or Exceed All Requirements of ASME B30.9 and B30.10
- 100% Proof Tested in Accordance with ASTM A952
- Additionally Hallmarked with "USA" and Date Code
- Made in the USA
- DO NOT EXCEED THE WORKING LOAD LIMIT

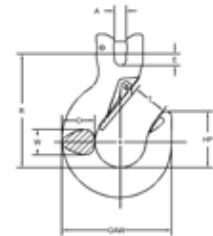

Chain Size	Cat. No.	UPC No.	Grade	WLL	Load Pin Dia.	A Dim.	D Dim.	E Dim.	HP	OAL	OAW	R Dim.	T Dim.	W Dim.	Wt. Each
9/32 in, 5/16 in	5746495PL	020418319259	100	5700 lb	3/8 in	23/64 in	1-11/32 in	23/64 in	1-23/32 in	3-13/16 in	3-13/16 in	4-1/32 in	1-11/64 in	27/32 in	1.85 lb
3/8 in	5746695PL	020418319280	100	8800 lb	1/2 in	1/2 in	1-37/64 in	13/32 in	2-3/8 in	4-23/32 in	4-23/32 in	5-1/16 in	1-15/32 in	1-5/16 in	3.66 lb
1/2 in	5746895PL	020418319303	100	15000 lb	5/8 in	39/64 in	2-7/64 in	5/8 in	2-61/64 in	5-61/64 in	5-61/64 in	6-7/32 in	1-11/16 in	1-3/8 in	7.60 lb
5/8 in	5747095PL	020418319327	100	22600 lb	3/4 in	47/64 in	2-37/64 in	3/4 in	3-21/64 in	7-5/32 in	7-5/32 in	7-5/32 in	2-5/64 in	1-3/4 in	11.04 lb
3/4 in	5747295PL	020418319341	100	35300 lb	15/16 in	55/64 in	3-3/32 in	57/64 in	3-49/64 in	8-9/16 in	8-9/16 in	7-21/32 in	2-23/64 in	2-1/16 in	18.52 lb



Hook Replacement Latches (PL Style)

- Replacement Latches for Eye & Swivel Hoist Hooks (PL Style)
- Replacement Latches for Cam-Alloy & Quik-Alloy Hooks (PL Style)
- New Latch Fits Integrated Forged Boss Design with Integrated Tip Hooks



Cat. No.	UPC No.	A Dim.	B Dim.	C Dim.	D Dim.	E Dim.	F Dim.	R Dim.	Latch Marking
7506295PL	020418306266	.75 in	.594 in	1.723 in	.515 in	.184 in	.32 in	.191 in	PL-3
7506495PL	020418306259	0.8 in	0.614 in	1.879 in	0.562 in	0.2 in	0.348 in	0.208 in	PL-4
7506695PL	020418306242	1 in	0.782 in	2.236 in	0.656 in	0.239 in	0.415 in	0.248 in	PL-5
7506895PL	020418306235	1.24 in	0.99 in	2.732 in	0.812 in	0.3 in	0.522 in	0.312 in	PL-7
7507095PL	020418295669	1.515 in	1.157 in	3.41 in	1 in	0.375 in	0.652 in	0.39 in	PL-8
7507295PL	020418295676	1.59 in	1.232 in	3.564 in	1.06 in	0.375 in	0.617 in	0.39 in	PL-9
7507495PL	020418295737	2.06 in	1.702 in	4.75 in	1.468 in	0.55 in	0.78 in	0.55 in	PL-10

Quik-Alloy Grab Hooks

- For Use with Grade 80/100 Chain Slings
- 4 to 1 Design Factor
- Meet or Exceed All Requirements of ASME B30.9 and B30.10
- 100% Proof Tested in Accordance with ASTM A952
- Additionally Hallmarked with "USA" and Date Code
- Made in the USA
- Note: Use of Chain in a Grab Hook as a Shortening Application May Result in a 20% WLL Reduction
- DO NOT EXCEED THE WORKING LOAD LIMIT

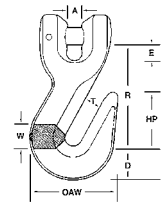

Chain Size	Cat. No.	UPC No.	Grade	WLL	Load Pin Dia.	A Dim.	D Dim.	E Dim.	HP	OAW	R Dim.	T Dim.	W Dim.	Weight Each	Shelf Pack
9/32 in	5724415	020418182600	100	4300 lb	3/8 in	5/16 in	13/16 in	11/32 in	1-1/4 in	2 in	2-11/32 in	3/8 in	5/8 in	0.60 lb	50
3/8 in	5724615	020418182617	100	8800 lb	1/2 in	7/16 in	1-1/4 in	1/2 in	1-5/8 in	2-13/16 in	2-29/32 in	1/2 in	3/4 in	1.60 lb	20
1/2 in	5724815	020418182624	100	15000 lb	5/8 in	9/16 in	1-1/2 in	5/8 in	2 in	3-1/2 in	3-23/32 in	21/32 in	15/16 in	3.50 lb	10
5/8 in	5725015	020418182631	100	22600 lb	3/4 in	23/32 in	1-3/4 in	3/4 in	2-5/8 in	4-1/8 in	4-7/16 in	25/32 in	1-7/32 in	5.40 lb	-
3/4 in	5725215	020418182648	100	35300 lb	7/8 in	13/16 in	2-1/8 in	7/8 in	3-1/4 in	4-7/8 in	5-1/8 in	31/32 in	1-3/8 in	12.40 lb	-

Self-Locking Clevis Hooks

- Meets the Intent of OSHA Regulation 1926.550(g)(4)(iv)(b)
- Meet or Exceed All Requirements of ASME B30.9 and B30.10
- Fatigue and 100% Proof Tested in Accordance with ASTM A952
- Additionally Hallmarked with "USA" and Date Code
- Latch Closes Automatically Under Load
- Trigger Assembly is Completely Replaceable
- Made in the USA
- DO NOT EXCEED THE WORKING LOAD LIMIT

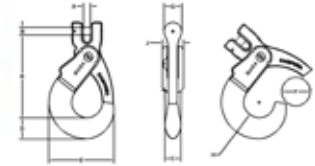

Chain Size	Cat. No.	UPC No.	Grade	Working Load Limit	Weight Each	Shelf Pack
9/32 in	5748495	020418193309	100	4300 lb	2.35 lb	-
3/8 in	5748695	020418193316	100	8800 lb	4.10 lb	-
1/2 in	5748895	020418193323	100	15000 lb	8.75 lb	1
5/8 in	5749095	020418193330	100	22600 lb	13.30 lb	1

Chain Size	Cat. No.	A Dim.	B Dim.	C Dim.	D Dim.	E Dim.	F Dim.	G Dim.	H Dim.	J Dim.	R Dim.
9/32 in	5748495	0.312 in	0.375 in	0.938 in	1.02 in	3.594 in	1.625 in	1.00 in	0.875 in	1.25 in	4.688 in
3/8 in	5748695	0.438 in	0.500 in	1.125 in	1.25 in	4.312 in	1.875 in	1.125 in	1.063 in	1.50 in	5.563 in
1/2 in	5748895	0.563 in	0.625 in	1.312 in	1.796 in	5.404 in	2.25 in	1.50 in	1.281 in	1.75 in	6.844 in
5/8 in	5749095	0.719 in	0.750 in	1.500 in	2.169 in	6.50 in	2.375 in	1.625 in	1.50 in	2.00 in	8.25 in

Cam-Alloy "S" Hooks

- Made of Heat-Treated Alloy Steel
- Proof Tested to 2 Times the Working Load Limit
- Meet Proof Test and Design Factor for Use in Alloy Chain Slings
- Working Load Limit is Embossed on the S-Hook Body
- Finish is Self Colored
- Made in the USA
- DO NOT EXCEED THE WORKING LOAD LIMIT

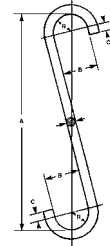

Trade Size	Cat. No.	UPC No.	A Dim.	B Dim.	C Dim.	R Dim.	Working Load Limit	Weight Each
9/32 in	T5610405	020418078262	2.75 in	0.75 in	0.38 in	0.38 in	250 lb	0.07 lb
3/8 in	5610605	020418078279	4.13 in	1.13 in	0.56 in	0.56 in	500 lb	0.34 lb
1/2 in	5610805	020418078286	5.50 in	1.50 in	0.75 in	0.75 in	1000 lb	0.59 lb
5/8 in	5611005	020418078293	7.00 in	1.88 in	0.94 in	0.94 in	1500 lb	1.24 lb
3/4 in	5611205	020418078309	8.25 in	2.25 in	1.13 in	1.13 in	2000 lb	2.31 lb
1 in	5611605	020418078323	11.00 in	3.00 in	1.50 in	1.50 in	3200 lb	4.45 lb



Cam-Alloy "J" Hooks

- Forged Alloy Steel
- Proof Tested to 2 Times the Working Load Limit
- Self Colored Finish
- Made in the USA
- DO NOT EXCEED THE WORKING LOAD LIMIT

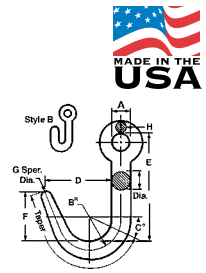

Cat. No.	UPC No.	Style	Material Diameter	Working Load Limit	B Dim.	C (Angle)	D Dim.	E Dim.	F Dim.	G Dim.	H Dim.	Weight Each
5616215	020418078484	A	3/4 in	2250 lb	1.31 in	25 °	2.69 in	4.38 in	2.06 in	0.38 in	0.467 in	0.85 lb
5616615	020418078491	B	1 in	3600 lb	2.00 in	90 °	3.64 in	6.75 in	4.00 in	0.28 in	0.467 in	2.37 lb
5616616	020418189777	A	1 in	3600 lb	2.00 in	25 °	4.13 in	6.75 in	3.88 in	0.28 in	0.467 in	2.38 lb

Field I.D. Tags

- Designed for Field Attachment
- Pre-Stamped for Easy Addition of Reach, Working Load Limit, Chain Size, Chain Grade and Serial Number
- Tag Measures 1 1/2" X 4 1/8" X 5/32" Thick and Has A 1/16" Diameter Hole
- Cut at Top of Tag Allows You to Attach to Sling Link
- Also Available Solid (Without Split)
- Box of 50 Tags (Order Unit is "Carton")

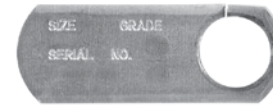

7503506

7503506C

Cat. No.	UPC No.	Style	Quantity Per Package	Weight Per Carton	Shelf Pack
7503506	020418135309	Split	50	12.80 lb	1
7503506C	020418217319	Solid	50	12.80 lb	1

CLAMPS

GXL Clamps	122
GX Clamps	123
E Clamps.....	125
Plate Clamps.....	126
Hand Grip Clamps.....	127





Campbell® Clamps

Though it began manufacturing operations in 1866, Campbell first made its lightweight, rugged plate lifting clamp in 1938. It was designed by an Englishman named Volz. Because it incorporated forged parts of heat treated, alloy steel, the Campbell clamp earned a worldwide reputation for reliability and long life. It is widely used by steel mills, warehouses and fabricating shops and is much preferred because its forged parts give increased strength yet are lightweight.

Campbell Lifting Clamps

Campbell clamps are known and used throughout the world for lifting, conveying and positioning of sheet, plate, weldments and structurals. The heavier the load, the tighter they grip. Parts are drop forged for strength, dependability and long life, and all clamps are individually proof tested. Replacement parts are available when needed. If you have any doubts as to the clamp best suited to your application, contact your Hillman Group salesman.

NOTICE: The product specifications and dimensions are as accurate as possible at the time of printing. However, because we are constantly improving the quality and design of our products, they can change without notice.

All Working Load Limits are expressed in Metric Tons.
1 Metric Ton = 2,204.6 lbs.

WARNING

1. Do not exceed Working Load Limit stamped on Clamp body.
2. Inspect clamp before each lift.
3. **Stand clear of load when lifting.**
4. Position clamp to balance load.
5. Insert plate or unit to full depth of throat opening.
6. Lift slowly and smoothly. Do not jerk load.
7. Do not lift more than one plate or sheet at a time.
8. Do not use a damaged clamp.
9. Read manufacturer's instructions before using clamps.
10. Do not use any Campbell clamp to lift tapered plates or beams.
11. When lifting plates with a hardness over 43 Rockwell C/400 BRINELL, use non-marring clamps only.
12. Campbell clamps are designed to be used at temperatures between 0°F and 200°F.

Inspection, Maintenance & Repair

It is important to establish a regular procedure for clamp inspection. Frequency of inspection will depend upon the amount of use the clamp receives. Campbell clamps are built to withstand rough treatment, however, grit, dirt, sludge and mud should be removed. This may be done easily by immersing the entire clamp in a can of degreaser and leaving it there overnight. Also, periodic oiling of all pins and rivets will improve performance and help to extend the life of the clamp. You may wish to maintain a written record, indicating inspection dates, condition of the clamp on each of those dates, and any repairs made. Inspection records should be reviewed periodically.

ADVERTENCIA

- Las mordazas en este catálogo no fueron diseñadas para ser utilizadas como conexión permanente de una placa o de otros objetos.
- El agarre depende de la fricción y de la presión entre ambas piezas. Si no se les da mantenimiento adecuado a las superficies de agarre y se utiliza la mordaza de manera inadecuada se puede caer la carga.
- Tenga mucha precaución cuando se va a elevar carga por encima de objetos o donde una falla puede ocasionar daños a la propiedad o lesiones personales.
- Lea los instructivos de uso y de mantenimiento.

WARNING

- The clamps in this catalog are not intended to serve as a permanent connection to a plate or other object.
- The grip depends on friction and a camming action. If the gripping surfaces are not properly maintained and the clamp is improperly used, the load may fall.
- Use extreme caution where overhead lifting is involved or where a failure could cause property damage or personal injury.
- Read maintenance materials and use instructions.

Inspection Procedure

1. Cams – These are the parts likely to receive most wear.

The amount of wear, of course, bears a direct relationship to the use the cam receives. Continued usage of plates of the same thickness will result in wear in only one area of the working surface of the cam, and will eventually require that the cam be replaced. The harder the plate is, the sooner the cam will be worn. A simple visual inspection of the cam is all that is required in most cases. The surfaces of the cam should be compared with unused surfaces. If any one tooth is worn or chipped more than 50% along the length of its crown, the cam should be replaced.

Note: *The Pad and Cam should be replaced at the same time.*

2. Pads – The pads of “GX” and “E” clamps are held in with a bolt and can be replaced simply by removing the bolt.

If any one tooth is worn or chipped more than 50% along the length of its crown, the pad should be replaced.

Note: *The Pad and Cam should be replaced at the same time.*

3. Spread Jaw – Check the throat width of the clamp.

At zero grip, the cam should be in full contact with the pad. If the width at the base (where the pad is located) is greater than the width at the top, the clamp has been overloaded and should be replaced.

Warning: *Do not weld on the clamp body, as this may destroy the original heat treatment.*

4. Linkage and Shackle Inspection – To remove the linkage from a “GX” clamp, remove the load pins from the body.

The pins do not rotate, and under normal load do not require

replacement. They should be inspected for bending, which is caused by overloads, and replaced as needed. Inspect the shackle for bending at the rivet, which is an indication of side pull. If this is a recurrent fault, use a chain connector on the clamp.

5. Rivet Inspection— Rivets may require replacement when a very loose connection is detected.

Linkage should normally be free working. Should a rivet hole in the shackle, radius link or connecting link become stretched or enlarged (usually resulting from overloading), those parts should be replaced. It is advisable to replace the rivet as well. To replace any worn parts, drive rivets out over a relief opening, such as a small section of pipe or the opening in a vise.

Warning: *Do not weld or substitute bolts for rivets. Check connecting links to ascertain that they are not bent.*

6. Spring inspection – The spring should be of sufficient strength to hold the cam against the pad.

If it is not, the spring should be replaced. In the case of the “E” clamp, the spring should be replaced if it fails to provide initial pressure at near zero grip.

7. Chains – Chains supplied with clamps should also be inspected carefully.

To do this, use a Campbell wear gauge. Inspect chains link by link, checking for distorted, stretched or cracked links, nicks or gouges, pitted links and excessive wear of bearing surfaces and barrels.



WARNING

To prevent the possibility of serious bodily injury:

- **DO NOT EXCEED** the working load limits for chain or components.
- **DO NOT USE** for overhead lifting or hoisting.
- **DO NOT USE** if the chain or components are visibly distorted or worn.



ADVERTENCIA

Para prevenir la posibilidad de una lesión personal seria:

- **NO EXCEDA** los límites de carga de las cadenas o componentes.
- **NO LA UTILICE** para cargar hacia arriba o para izar.
- **NO LA UTILICE** si la cadena o los componentes están visualmente distorsionados o gastados.



GXL Clamps

- Available in a 1/2, 1, and 2 Metric Ton Capacities
- Can Be Used for Both Vertical and Horizontal to Vertical Lifting Through 180°
- Drop Forged and Heat Treated Components, with Gripping Surfaces of Case Hardened Alloy Steel.
- Exclusive Feature is a Wear Indicator System. When Any of the Cam's Straight Line, Convex Teeth Are Flattened Between Unique Wear Indicator Grooves, It is Time to Change the Cam.
- Note: The Pad and Cam Should Be Replaced at the Same Time
- Newly Designed "Cam Engaging Locking Lever" Keeps the Cam in Contact with the Plate. The Tension Arm and Spring Mechanism Facilitate Attaching and Removing the Clamp. These Clamps Will Not Lift Plate When in the "Lever Open" Position
- Clamps Are 100% Proof Tested and Certificate of Test Supplied with Each Clamp
- Minimum WLL of at Least 10% of the Maximum WLL
- Warning: NEVER Tamper with a Clamps Tension Arm or Spring Mechanism During a Lift.

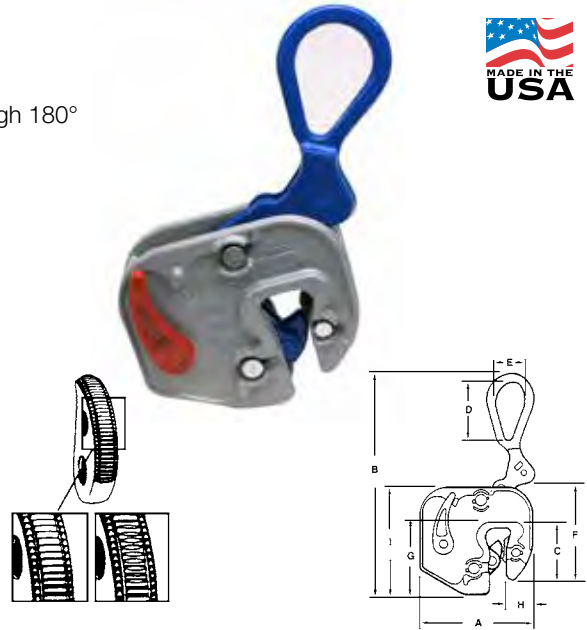

Cat. No.	UPC No.	Grip Range	WLL(Metric Tons)	A Dim.	B Dim.	C Dim.	D Dim.	E Dim.	F Dim.	G Dim.	H Dim.	I Dim.	Weight Each
6422012	020418187049	1/16 to 5/8 in.	1/2 t	5-15/16 in	10 in	2-1/8 in	2-5/8 in	2 in	4 in	3-1/4 in	1-3/16 in	5-3/16 in	5.50 lb
6422001	020418185687	1/16 to 3/4 in.	1 t	6-9/16 in	11-1/4 in	3-13/16 in	3-1/16 in	2-1/16 in	5 in	3-5/8 in	1-5/8 in	5-7/8 in	8.00 lb
6422002	020418187032	1/16 to 7/8 in.	2 t	7-1/4 in	12-1/8 in	2-9/16 in	3-5/16 in	2-1/4 in	4-7/8 in	3-1/2 in	1-5/8 in	5-15/16 in	10.50 lb

Repair Kits for "GXL" Clamps

- Replacement Part Kits for All "GXL" Style Clamps
- Kits Contain All Necessary Parts for Shackle or Cam/Pad Replacement
- Shackle Kit Includes: 1 Shackle, 1 Radius Link, 1 T-Spring, 2 Connecting Links, 1 Radius Link Pin, 1 Pivot, 1 Lever, 1 E-Spring, 2 Sel-Locs, 3 Linkage Rivets, 1 Drive Pin
- Note: Shackle Kit is Supplied Pre-Assembled for Easier Installation
- Cam/Pad Kit Includes: 1 Cam, 1 Pad, 1 Cam Pin, 1 Pad Pin, 1 T-Spring, 1 E-Spring, 1 Rivet, 4 Sel-Locs
- Note: The Cam and Pad Should Be Replaced at the Same Time

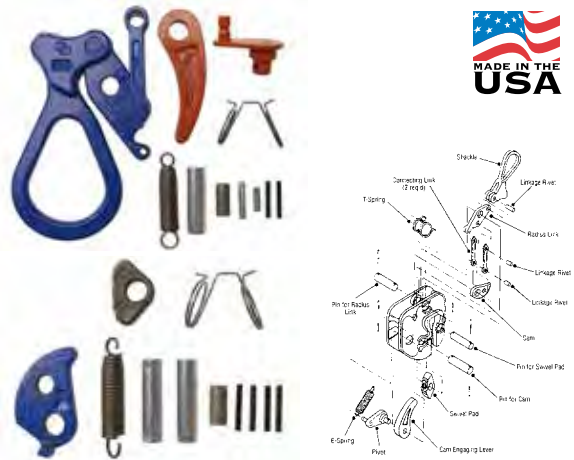

Cat. No.	UPC No.	Part Name	For Use With Clamp Capacity	Weight Each
6506200	020418210204	Shackle Kit	1/2 TON	3.00 lb
6506201	020418210211	Cam/Pad Kit	1/2 TON	0.50 lb
6506210	020418210228	Shackle Kit	1 TON	3.00 lb
6506211	020418210235	Cam/Pad Kit	1 TON	1.00 lb
6506220	020418210242	Shackle Kit	2 TON	3.80 lb
6506221	020418210259	Cam/Pad Kit	2 TON	1.20 lb

GX Clamps

- Features Drop-Forged and Heat Treated Body and Components
- Can Be Used for Both Vertical and Horizontal to Vertical Lifting Through 180°
- Exclusive Feature is a Wear Indicator System. When Any of the Cam's Straight Line, Convex Teeth Are Flattened Between Unique Wear Indicator Grooves, It is Time to Change the Cam.
- Note: The Pad and Cam Should Be Replaced at the Same Time
- Clamps Are 100% Proof Tested and Certificate of Test Supplied with Each Clamp
- Minimum WLL of at Least 10% of the Maximum WLL

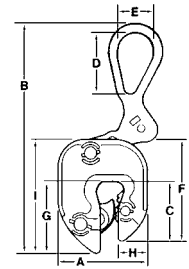

Cat. No.	UPC No.	Grip Range	WLL (Metric Tons)	A Dim.	B Dim.	C Dim.	D Dim.	E Dim.	F Dim.	G Dim.	H Dim.	I Dim.	Weight Each
6423000	020418172199	1/16 to 5/8 in.	1/2 t	4 in	9-1/2 in	2-3/16 in	2-3/4 in	2 in	4-1/8 in	2-7/8 in	1-3/8 in	4-7/8 in	4.00 lb
6423005	020418172205	1/16 to 3/4 in.	1 t	4-3/4 in	11-1/4 in	3-1/16 in	3-1/16 in	2-1/16 in	5-1/4 in	3-5/8 in	1-5/8 in	5-7/8 in	8.00 lb
6423923	020418175664	3/4 to 1-3/8 in.	1 t	5-7/8 in	11-1/4 in	3-1/16 in	3-1/16 in	2-1/16 in	5-1/4 in	3-5/8 in	1-5/8 in	5-7/8 in	9.00 lb
6423010	020418172229	1/16 to 1 in.	3 t	6 in	14 in	3-9/16 in	3-13/16 in	3 in	6-3/4 in	4-7/16 in	2 in	7-5/8 in	17.00 lb

Short Leg Structural "GX" Clamps

- Designed for a Secure Bite on Small or Odd Shaped, Wide Flanged Beams
- Can Be Used for Both Vertical and Horizontal to Vertical Lifting Through 180°
- Put Short Leg Under Plate When Lifting From Horizontal to Vertical
- Replacement Parts Are Same As for Standard "GX" Clamps
- Note: The Pad and Cam Should Be Replaced at the Same Time
- Clamps Are 100% Proof Tested and Certificate of Test Supplied with Each Clamp
- Minimum WLL of at Least 10% of the Maximum WLL

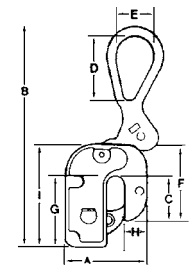

Cat. No.	UPC No.	Grip Range	WLL (Metric Tons)	A Dim.	B Dim.	C Dim.	D Dim.	E Dim.	F Dim.	G Dim.	H Dim.	I Dim.	Weight Each
6423100	020418177330	1/16 to 5/8 in.	1/2 t	4 in	9-1/2 in	2-1/8 in	2-5/8 in	2 in	4-1/16 in	2-7/8 in	1-3/8 in	4-3/4 in	4.25 lb
6423105	020418177347	1/16 to 3/4 in.	1 t	4-3/4 in	11-5/16 in	2-5/8 in	3-1/16 in	2-1/16 in	4-7/8 in	3-9/16 in	1-21/32 in	5-13/16 in	8.00 lb
6423108	020418183041	1/16 to 7/8 in.	2 t	5-1/8 in	12-1/8 in	2-5/8 in	3-5/16 in	2-1/4 in	5 in	3-9/16 in	1-5/8 in	5-15/16 in	10.00 lb
6423110	020418177354	1/16 to 1 in.	3 t	6 in	15-1/16 in	3-7/16 in	3-13/16 in	3 in	6-9/16 in	4-3/16 in	2 in	7-5/16 in	18.00 lb



Repair Kits for "GX" Clamps

- Replacement Part Kits for All "GX" Style Clamps
- Kits Contain All Necessary Parts for Shackle or Cam/Pad Replacement
- Shackle Kit Includes: 1 Shackle, 1 Radius Link, 1 T-Spring, 2 Connecting Links, 1 Radius Link Pin, 3 Linkage Rivets, 4 Sel-Locs
- Note: Shackle Kit is Supplied Pre-Assembled for Easier Installation
- Cam/Pad Kit Includes: 1 Cam, 1 Pad, 1 Cam Pin, 1 Pad Pin, 1 T-Spring, 1 Rivet, 4 Sel-Locs
- Note: The Cam and Pad Should Be Replaced at the Same Time

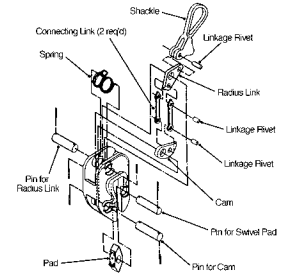

Cat. No.	UPC No.	Part Name	For Use With Clamp Capacity	Weight Each
6506000	020418210013	Shackle Kit	1/2 TON	1.00 lb
6506001	020418210020	Cam/Pad Kit	1/2 TON	0.50 lb
6506010	020418210037	Shackle Kit	1 TON	1.00 lb
6506011	020418210044	Cam/Pad Kit	1 TON	0.80 lb
6506020	020418210051	Shackle Kit	2 TON	1.00 lb
6506021	020418210068	Cam/Pad Kit	2 TON	1.50 lb
6506030	020418210075	Shackle Kit	3 TON	6.00 lb
6506031	020418210082	Cam/Pad Kit	3 TON	4.00 lb

Chain Connector Clamps

- "GX" Style Chain Connector Clamp
- Clamp Comes Fitted with Chain Connector in Place of the Clamp Shackle
- Use of This Clamp Increases the Flexibility of Multiple Leg Chain Slings
- Clamp is Made of Drop Forged and Heat Treated Alloy Steel
- Minimum WLL of at Least 10% of the Maximum WLL



Cat. No.	UPC No.	Style	Grip Range	Working Load Limit (Metric Tons)	Weight Each
6423900	020418175947	Regular "GX"	1/16 to 5/16 in.	1/2 t	4.50 lb
6423905	020418175954	Regular "GX"	1/16 to 3/4 in.	1 t	9.00 lb

Sharp Leg “GX” Style Clamps

- Designed to Lift Stacked Plates From Horizontal to Vertical Positions in A 90° Arc (Not 180°)
- Long Sharp Leg Can Be Driven Between Top Two Plates to Fully Engage the Clamp
- Clamps Are 100% Proof Tested and Certificate of Test Supplied with Each Clamp
- Minimum WLL of at Least 10% of the Maximum WLL
- Replacement Parts Are Same As for Standard “GX” Clamps

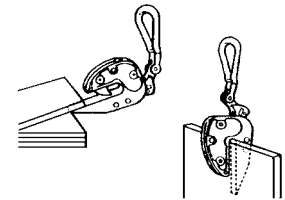

Cat. No.	UPC No.	Grip Range	Working Load Limit (Metric Tons)	Weight Each
6423500		1/16 to 5/8 in.	1/2 t	5.00 lb

Locking “E” Clamps

- Clamp Lifts From Either Horizontal or Vertical Position
- Clamps Turn Plates Through 90°
- Locks Open or Closed with a Lever
- Has Large Throat That Gives a Secure Bite and Wide Grip Range
- Clamps Are 100% Proof Tested and Certificate of Test Supplied
- Minimum WLL of at Least 10% of the Maximum WLL
- Note: Be Sure Clamp is in Lock Closed Position Before Making Lift
- Warning: NEVER Tamper with a Clamps Tension Arm or Spring Mechanism During a Lift. DO NOT Add Rope or Other Material to the Lock Mechanism to Lengthen.

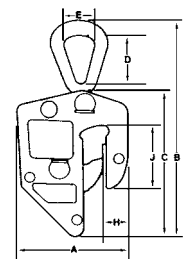

Cat. No.	UPC No.	Model No.	Grip Range	WLL (Metric Tons)	A Dim.	B Dim.	C Dim.	D Dim.	E Dim.	H Dim.	J Dim.	Weight Each
6420701	020418096112	3E	0 to 1-1/4 in.	3 t	7-1/4 in	14-3/8 in	9-1/4 in	3-1/2 in	2 in	2 in	4-3/8 in	20.00 lb
6420702	020418096129	5E	0 to 1-1/2 in.	5 t	9-5/8 in	16-1/8 in	10-3/16 in	3-1/2 in	2-1/2 in	3-3/16 in	5-5/16 in	28.00 lb
6420703	020418096136	5E	1-1/4 to 2-1/2 in.	5 t	10-9/16 in	16-5/8 in	11-1/8 in	3-1/2 in	2-1/2 in	3-3/16 in	5-5/16 in	33.00 lb



Repair Kits for Locking “E” Clamps

- Replacement Part Kits for All “E” Style Clamps
- Kits Contain All Necessary Parts for Shackle or Cam/Pad Replacement
- Shackle Kit Includes: 1 Shackle, 1 Shackle Bolt, 1 Nut, 1 Cotter Pin
- Cam/Pad Kit w/ Tension Arm Includes: 1 Cam, 1 Pad, 1 Cam Bolt, 1 Pad Bolt, 2 Nuts, 2 Rivets, 1 Drive Pin, 1 Spring, 1 Chain Pull, 1 Chain Pull Clip, 1 Tension Arm, 2 Swivel Pins, 2 Cotter Pins
- Cam/Pad Kit Includes: 1 Cam, 1 Pad, 1 Cam Bolt, 1 Pad Bolt, 2 Nuts, 1 Rivet, 2 Cotter Pins
- Note: The Cam and Pad Should Be Replaced at the Same Time

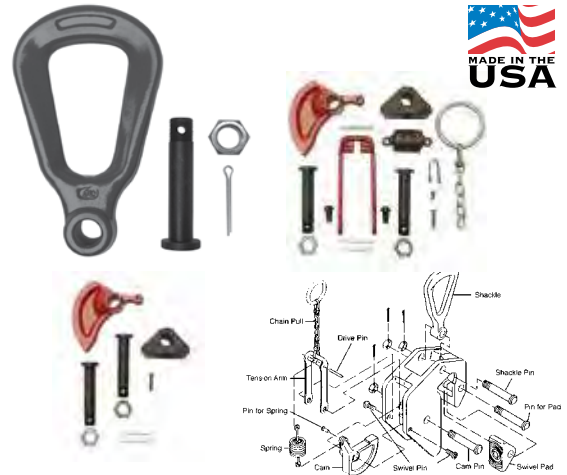

Cat. No.	UPC No.	Part Name	For Use With Clamp Capacity	Grip Range	Weight Each	Shelf Pack
6507030	020418210440	Shackle Kit	3 TON	All Grips	3.50 lb	-
6507031	020418210457	Cam/Pad/Tension Arm Kit	3 TON	All Grips	5.00 lb	-
6507032	020418227684	Cam/Pad Kit	3 TON	All Grips	2.50 lb	1
6507050	020418210464	Shackle Kit	5 TON	All Grips	3.70 lb	-
6507051	020418210471	Cam/Pad/Tension Arm Kit	5 TON	All Grips	5.60 lb	-
6507052	020418227691	Cam/Pad Kit	5 TON	All Grips	4.50 lb	1

SAC (Screw-Adjusted Cam) Plate Clamps

- Recommended for Turning Plates From Horizontal to Vertical As Well As Through A 180° Arc
- The Convex, Serrated Cam Swivels on A Ball Joint So That the Area of Cam Engagement Increases As Load Increases
- Drop Forged Body and Shackle
- Clamps Are 100% Proof Tested and Certificate of Test Supplied with Each Clamp
- Minimum WLL of at Least 10% of the Maximum WLL
- Note: Clamp Features a Torque Limiting Handle to Prevent Overtightening. Screw Needs to Be Hand Tightened Only! Do Not Overtighten.

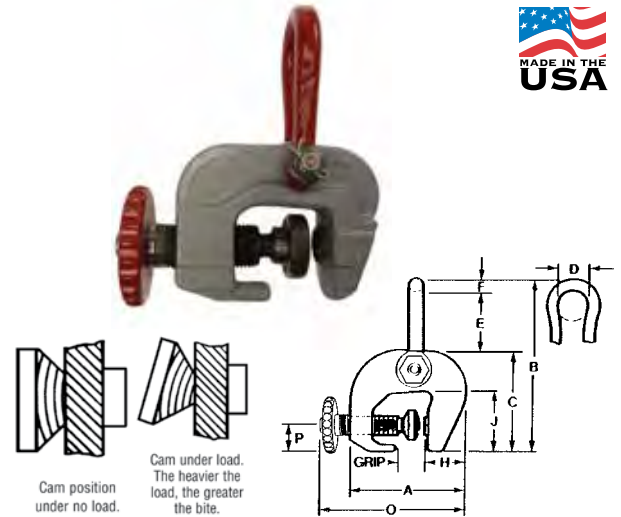

Cat. No.	UPC No.	Model Number	Grip Range	Working Load Limit (Metric Tons)	Weight Each
6421000	020418096396	SAC-1	0 to 1 in.	1 t	6.25 lb
6421001	020418096402	SAC-3	0 to 2 in.	3 t	17.00 lb
6421002	020418096419	SAC-6	0 to 3 in.	6 t	39.00 lb

Model Number	A Dim.	B Dim.	C Dim.	D Dim.	E Dim.	F Dim.	H Dim.	J Dim.	O Dim.	P Dim.
SAC-1	5-1/4 in	7-3/4 in	4 in	1-3/4 in	2-7/8 in	1/2 in	1-1/2 in	2-1/4 in	6-1/4 in	1-23/64 in
SAC-3	7-3/4 in	10-1/2 in	6-1/2 in	1-7/8 in	3-3/8 in	3/4 in	2-3/8 in	3-3/4 in	9-1/4 in	1-13/16 in
SAC-6	10 in	14-1/4 in	8-1/4 in	3-1/4 in	4-1/2 in	1-1/8 in	3 in	4-1/2 in	12 in	2-1/4 in

Repair Kits for SAC Clamps

- Replacement Part Kits for All "SAC" Style Clamps
- Kits Contain All Necessary Parts for Shackle, Screw and Handle or Cam/Pad Replacement
- Cam/Pad Kit Includes: 1 Cam, 1 Pad, 1 Pad Bolt, 1 Nut, 1 Washer
- Screw w/Handle Kit Includes: 1 Screw, 1 Handle
- Shackle w/Bolt Kit Includes: 1 Shackle, 1 Bolt, 1 Nut, 1 Cotter Key
- Note: The Cam and Pad Should Be Replaced at the Same Time

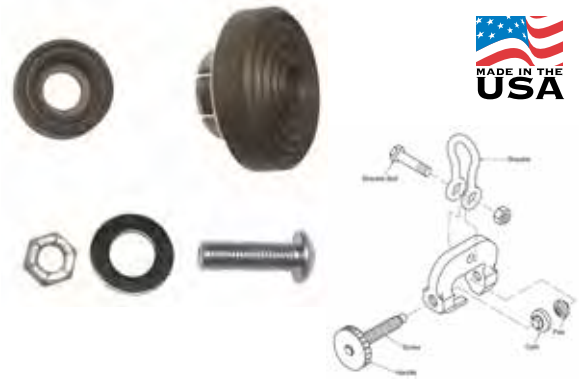

Cat. No.	UPC No.	Part Name	For Use With Clamp Capacity	Weight Each
6501000	020418210112	Cam/Pad Kit	SAC - 1	0.40 lb
6501101	020418211942	Screw w/Handle Kit	SAC - 1	1.65 lb
6501111	020418211959	Shackle w/Bolt Kit	SAC - 1	1.00 lb
6501010	020418210129	Cam/Pad Kit	SAC - 3	0.80 lb
6501011	020418211904	Screw w/Handle Kit	SAC - 3	4.25 lb
6501012	020418211911	Shackle w/Bolt Kit	SAC - 3	2.80 lb
6501020	020418210136	Cam/Pad Kit	SAC - 6	1.50 lb
6501021	020418211928	Screw w/Handle Kit	SAC - 6	6.35 lb
6501022	020418211935	Shackle w/Bolt Kit	SAC - 6	8.35 lb

Duplex Hand Grip Clamps

- Designed to Carry or Pull Any Object That Will Fit Into Its Jaws
- Features One Piece Cast Alloy Body for Strength and Durability
- Grips and Releases Automatically



Cat. No.	UPC No.	Grip Range	Handle Length	C Dim.	J Dim.	O Dim.	Weight Each
6421801	020418096693	0 to 5/16 in.	2 in	6 in	1-7/8 in	3-3/4 in	1.15 lb
6421802	020418096709	0 to 5/16 in.	Eye Nut	8 in	1-7/8 in	3-3/4 in	2.10 lb
6421803	020418096716	0 to 5/16 in.	6 in	12 in	1-7/8 in	3-3/4 in	2.00 lb
6421805	020418096723	0 to 5/16 in.	10 in	16 in	1-7/8 in	3-3/4 in	3.00 lb
6421806	020418096730	0 to 5/16 in.	18 in	23 in	1-7/8 in	3-3/4 in	4.00 lb

CATALOG NUMBER	PAGE	CATALOG NUMBER	PAGE	CATALOG NUMBER	PAGE
CHAINS					
1005505.....	35	T0120400.....	7	T0180512.....	10
5977920.....	38	T0120402.....	7	T0180522.....	10
7000197.....	34	T0120422.....	7	T0180532.....	10
7000227.....	34	T0120430.....	7	T0180612.....	10
7000327.....	34	T0120432.....	7	T0180632.....	10
7000397.....	34	T0120500.....	7	T0180812.....	10
7000426.....	35	T0120502.....	7	T0180832.....	10
7000427.....	34	T0120522.....	7	T0181012.....	10
7000497.....	34	T0120530.....	7	T0181032.....	10
7000626.....	35	T0120532.....	7	T0181092.....	12
7000627.....	34	T0120600.....	7	T0181212.....	10
7000697.....	34	T0120602.....	7	T0181413.....	11
7000797.....	34	T0120622.....	7	T0181423.....	11
7000826.....	35	T0120630.....	7	T0181513.....	11
7000827.....	34	T0120632.....	7	T0181523.....	11
7000897.....	34	T0120732.....	7	T0181613.....	11
7000927.....	34	T0120802.....	7	T0181623.....	11
7508495.....	38	T0120822.....	7	T0184416.....	11
7508595.....	38	T0120832.....	7	T0184516.....	11
AW0310427.....	19	T0121002.....	7	T0184536.....	11
AW0320427.....	19	T0121032.....	7	T0184616.....	11
AW0330427.....	21	T0121202.....	7	T0184636.....	11
AW0751024N.....	27	T0121232.....	7	T0187232.....	12
AW0801027N.....	29	T0129332.....	10	T0213505.....	35
AW0801227N.....	29	T0129432.....	10	T0222725.....	36
AW0801427N.....	29	T0129532.....	10	T0222925.....	36
HV0184526.....	12	T0129632.....	10	T0223698.....	36
PA0722027N.....	27	T0140323.....	8	T0223820.....	36
PB0722827N.....	29	T0140333.....	8	T0226615.....	36
PD0143426.....	9	T0140423.....	8	T0231912.....	37
PD0722027N.....	27	T0140433.....	8	T0231916.....	37
PD0722087N.....	27	T0140523.....	8	T0304024.....	23
PD0722127.....	9	T0140533.....	8	T0309526.....	23
PD0722627.....	21	T0140623.....	8	T0310124.....	18
PD0725027.....	9	T0140633.....	8	T0310224.....	18
PD0752496N.....	28	T0140823.....	8	T0310324.....	18
PG0722227N.....	27	T0143226.....	8	T0310424.....	18
PS0332027.....	20	T0143326.....	8	T0311024.....	18
T0120202.....	7	T0143336.....	8	T0312024.....	18
T0120232.....	7	T0143426.....	8	T0313024.....	18
T0120300.....	7	T0143436.....	8	T0314024.....	18
T0120302.....	7	T0143526.....	8	T0315024.....	18
T0120322.....	7	T0143536.....	8	T0320224.....	19
T0120330.....	7	T0143626.....	8	T0320324.....	19
T0120332.....	7	T0143636.....	8	T0321024.....	19
		T0180412.....	10	T0322026.....	20
		T0180422.....	10	T0324024.....	19
		T0180432.....	10	T0330124.....	20

CATALOG NUMBER	PAGE	CATALOG NUMBER	PAGE	CATALOG NUMBER	PAGE
T0330126.....	22	T0513660.....	37	T0723167.....	22
T0330224.....	20	T0513665.....	37	T0723169.....	24
T0330424.....	20	T0513667.....	37	T0723227N.....	27
T0331024.....	20	T0513668.....	37	T0723367.....	19
T0331026.....	22	T0513678.....	37	T0723427.....	25
T0332023.....	21	T0513698.....	37	T0723627.....	21
T0332024.....	20	T0513765.....	37	T0723727N.....	31
T0332426.....	22	T0514632.....	15	T0723817N.....	26
T0333024.....	20	T0514832.....	15	T0724027N.....	29
T0334024.....	20	T0514932.....	15	T0724527.....	21
T0335024.....	20	T0516531.....	16	T0724627N.....	27
T0335026.....	22	T0520612.....	16	T0725027.....	9
T0336015.....	18	T0520812.....	16	T0726427N.....	27
T0339626.....	24	T0521012.....	16	T0726627.....	19
T0340324.....	22	T0635211.....	17	T0726727.....	19
T0400512.....	16	T0702024N.....	38	T0726827.....	21
T0401612.....	16	T0710227.....	32	T0740224.....	24
T0402012.....	16	T0710317.....	32	T0740234.....	24
T0405212.....	17	T0710517.....	32	T0740237.....	25
T0405312.....	17	T0710717.....	32	T0741024.....	24
T0405412.....	17	T0711917.....	33	T0741034.....	24
T0405512.....	17	T0712017.....	32	T0741037.....	25
T0405612.....	17	T0713027.....	32	T0742024.....	25
T0405712.....	17	T0717017.....	32	T0742034.....	25
T0405812.....	17	T0719027.....	32	T0743024.....	25
T0407512.....	13	T0720127N.....	27	T0744024.....	25
T0407612.....	13	T0720428N.....	31	T0744027.....	25
T0510410.....	14	T0721627N.....	29	T0744037.....	25
T0510412.....	13	T0721667N.....	29	T0745024.....	25
T0510413.....	14	T0721727N.....	29	T0745037.....	25
T0510426.....	15	T0722000.....	31	T0750124N.....	26
T0510510.....	14	T0722002N.....	31	T0750224N.....	26
T0510512.....	13	T0722003N.....	31	T0750227N.....	27
T0510513.....	14	T0722004N.....	31	T0750324N.....	26
T0510526.....	15	T0722006N.....	31	T0750424N.....	26
T0510610.....	14	T0722007N.....	31	T0751034N.....	26
T0510612.....	13	T0722010.....	31	T0752023N.....	27
T0510613.....	14	T0722027N.....	27	T0752024N.....	26
T0510626.....	15	T0722087N.....	27	T0752034N.....	26
T0510712.....	13	T0722127.....	9	T0752426N.....	28
T0510810.....	14	T0722227.....	9	T0754034N.....	26
T0510812.....	13	T0722327.....	9	T0754126N.....	28
T0513572.....	36	T0722427.....	25	T0754326N.....	28
T0513574.....	37	T0722527.....	19	T0758034.....	26
T0513575.....	37	T0722627N.....	27	T0762024N.....	28
T0513576.....	37	T0722827.....	21	T0762026N.....	28
T0513578.....	37	T0722927.....	23	T0800824N.....	29
T0513598.....	37	T0722957.....	23	T0801024N.....	29

CATALOG NUMBER	PAGE	CATALOG NUMBER	PAGE	CATALOG NUMBER	PAGE
T7605801.....	48	T7625404.....	51	T7645156V.....	53
T7605811.....	48	T7625434.....	51	T7655002N.....	55
T7605821.....	48	T7625504.....	51	T7655012N.....	55
T7606001.....	48	T7625604.....	51	T7655022N.....	55
T7606011.....	48	T7625614.....	51	T7655032N.....	55
T7606021.....	48	T7630406.....	54	T7655042N.....	55
T7606031.....	48	T7630416.....	54	T7655052N.....	55
T7606301.....	49	T7630426.....	54	T7655062N.....	55
T7606502.....	49	T7630436.....	54	T7655100N.....	55
T7606801.....	49	T7630446.....	54	T7655112N.....	55
T7607301.....	49	T7630506.....	54	T7655120N.....	55
T7607401.....	49	T7630526.....	54	T7655132N.....	55
T7607602.....	49	T7630536.....	54	T7655142N.....	55
T7607702.....	49	T7630546.....	54	T7655202N.....	55
T7610102.....	50	T7630556.....	54	T7655212N.....	55
T7610832.....	50	T7631204.....	52	T7655402-02.....	57
T7615012.....	50	T7631304.....	52	T7655404.....	57
T7615102.....	50	T7631324.....	52	T7655412-02.....	57
T7615202.....	50	T7631404.....	52	T7655422-02.....	57
T7615302.....	50	T7631414.....	52	T7660841.....	46
T7615312.....	50	T7631434.....	52	T7661152.....	46
T7615402.....	50	T7631524.....	52	T7661361.....	46
T7615412.....	50	T7631534.....	52	T7662114.....	46
T7615422.....	50	T7631604.....	52	T7662154.....	46
T7615502.....	50	T7631614.....	52	T7662322.....	47
T7615602.....	50	T7631704.....	52	T7662342.....	47
T7615802.....	50	T7631804.....	52	T7662351.....	47
T7615902.....	50	T7633002.....	59	T7662372.....	47
T7616202.....	47	T7633003.....	59	T7663550.....	46
T7616302.....	50	T7633004.....	59	T7665001.....	46
T7616402.....	50	T7637502.....	59	T7665012.....	46
T7616412.....	50	T7637503.....	59	T7665032.....	46
T7616602.....	50	T7637504.....	59	T7665042.....	46
T7616702.....	50	T7640302.....	47	T7670409.....	58
T7620334.....	51	T7640322.....	47	T7670419.....	58
T7620534.....	51	T7645000.....	52	T7670429.....	58
T7620614.....	51	T7645006.....	53	T7670439.....	58
T7620804.....	51	T7645016.....	53	T7670449.....	58
T7620934.....	49	T7645026.....	53	T7670459.....	58
T7625004.....	51	T7645036.....	53	T7670479.....	58
T7625014.....	51	T7645046.....	53	T7670489.....	58
T7625104.....	51	T7645066.....	53	T7670499.....	58
T7625114.....	51	T7645074.....	53	T7670609.....	58
T7625124.....	51	T7645106V.....	53	T7670619.....	58
T7625204.....	51	T7645116V.....	53	T7670629.....	58
T7625304.....	51	T7645126V.....	53	T7670639.....	58
T7625314.....	51	T7645136V.....	53	T7670649.....	58
T7625324.....	51	T7645146V.....	53	T7670659.....	58



Customer Service U.S.

Phone: 866-907-9716

Email: CustomerCare@apextoolgroup.com

Customer Service Canada

Phone: 866-691-6212

Email: CSRCanada@apextoolgroup.com

Customer Service Export

Phone: 919-387-2402

Email: CSRExport@apextoolgroup.com

Apex Tool Group World Headquarters

910 Ridgebrook Rd, Suite 200

Sparks, MD 21152

(410) 773-7800



1000 Lufkin Road, Apex, North Carolina 27539

www.apextoolgroup.com